

SPI/QPI PSRAM

Specifications

- **Single Supply Voltage**
 - VDD=2.7 to 3.6V
- **Interface:** SPI/QPI with SDR mode
- **Performance:** Clock rate up to
 - 133MHz for 32 Bytes Wrapped Burst operation at VDD=3.0V+/-10%
 - 109MHz for 32 Bytes Wrapped Burst operation at VDD=3.3V+/-10%
 - 84MHz for Linear Burst operation
- **Organization:** 64Mb, 8M x 8bits
- **Addressable Bit Range:** A[22:0]
- **Page Size:** 1024 bytes
- **Refresh:** Self-managed
- **Operating Temperature Range:**
 - Tc = -40°C to +85°C (standard range)
 - Tc = -40°C to +105°C (extended range)
- **Maximum Standby Current**
 - 350µA @ 105°C
 - 250µA @ 85°C
 - 140µA @ 25°C

Features

- **50Ω Output Drive Strength LVCMOS**
- **Linear Burst** (continuous) or **32 Bytes Wrapped Burst** via toggle command.
- **Linear Burst** is supported up to 84MHz and can cross page boundary as long as tCEM is met.
- **Software reset**

Table of Contents

1 Table of Contents

1	Table of Contents.....	2
2	Introduction	4
3	Package Information.....	4
3.1	Package Types : SOP / USON (SN, ZR) , not to scale, Top view.....	4
4	Package Outline Drawing.....	5
4.1	SOP-8L(150), package code SN	5
4.2	USON-8L 3x2mm, package code ZR.....	6
5	Ordering Information.....	7
6	Signal Table	8
7	Power-Up Initialization	8
8	Interface Description	9
8.1	Address Space	9
8.2	Page Size	9
8.3	Drive Strength	9
8.4	Power-on Status.....	9
8.5	Command/Address Latching Truth Table.....	9
8.6	Command Termination.....	10
9	Wrap Boundary Toggle Operation.....	11
10	SPI Mode Operations	12
10.1	SPI Read Operations.....	12
10.2	SPI Write Operations.....	14
10.3	SPI Quad Mode Enable Operation	15
10.4	SPI Read ID Operation.....	15
11	QPI Mode Operations	16
11.1	QPI Read Operation	16
11.2	QPI Write Operation(s)	17
11.3	QPI Quad Mode Exit operation.....	17
12	Reset Operation	18

13	Input/Output Timing.....	19
14	Electrical Specifications:	20
14.1	Absolute Maximum Ratings.....	20
14.2	Pin Capacitance.....	20
14.3	Decoupling Capacitor Requirement.....	21
14.4	Operating Conditions.....	21
14.5	DC Characteristics	22
14.6	AC Characteristics	23
15	Change Log.....	24

2 Introduction

This Pseudo-SRAM device features a high speed, low pin count interface. It has 4 SDR I/O pins and operates in SPI(serial peripheral interface) or QPI (quad peripheral interface) mode with frequencies up to 133 MHz. The data input (A/DQ) to the memory relies on clock (CLK) to latch all instructions, addresses and data. It is most suitable for low-power and low cost portable applications. It incorporates a seamless self-managed refresh mechanism. Hence it does not require the support of DRAM refresh from system host. The self-refresh feature is a special design to maximize performance of memory read operation.

3 Package Information

The APS6404L-3SQR is available in standard package including 8-lead SOP-8L(150) and advanced package including 8-lead USON-8L 3x2mm.

3.1 Package Types : SOP / USON (SN, ZR) , not to scale, Top view

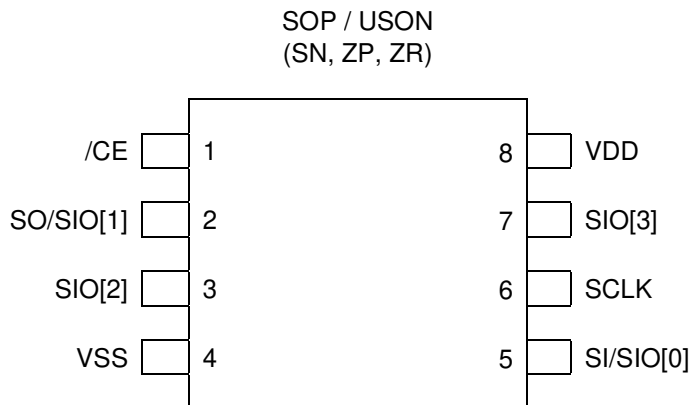

4 Package Outline Drawing

4.1 SOP-8L(150), package code SN

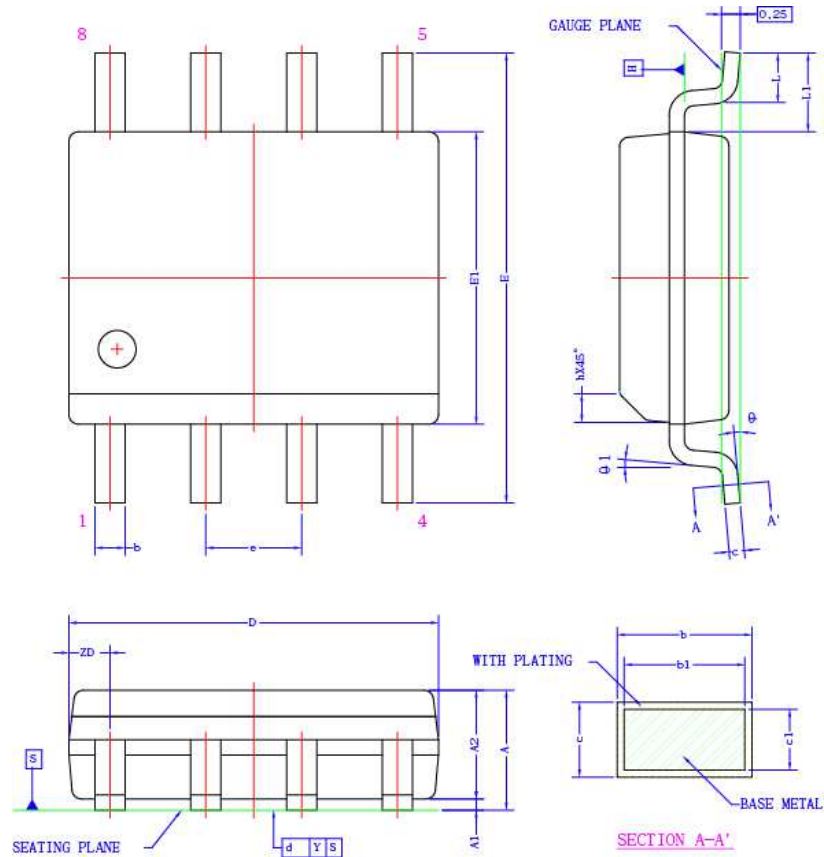

SYMBOL	DIMENSION (MM)			DIMENSION (MIL)		
	MIN.	NOM.	MAX.	MIN.	NOM.	MAX.
A	1.35	1.60	1.75	53	63	69
A1	0.10	0.15	0.25	4	6	10
A2	1.35	1.45	1.55	53	57	61
b	0.31	-	0.51	12	-	20
b1	0.28	0.40	0.48	11	16	19
c	0.17	-	0.25	7	-	10
c1	0.17	0.20	0.23	7	8	9
D	4.80	4.90	5.00	189	193	197
E	6.00 BSC			236 BSC		
E1	3.80	3.90	4.00	150	154	157
e	1.27 BSC			50 BSC		
L	0.40	0.66	1.27	16	26	50
L1	1.05 REF			41 REF		
ZD	0.55 REF			22 REF		
h	0.25	0.38	0.50	10	15	20
Y	-	-	0.10	-	-	4
θ	0°	-	8°	0°	-	8°
$\theta 1$	0°	-	-	0°	-	-

NOTE :

- REFER TO JEDEC STD: MS-012 AA.
- DIMENSION 'D' DOES NOT INCLUDE MOLD FLASH, PROTRUSION OR GATE BURRS. MOLD FLASH, PROTRUSION AND GATE BURRS SHALL NOT EXCEED 0.15mm PER SIDE.
DIMENSION 'E1' DOES NOT INCLUDE INTERLEAD MOLD FLASH OR PROTRUSION. INTERLEAD MOLD FLASH OR PROTRUSION SHALL NOT EXCEED 0.25mm PER SIDE.
'D' AND 'E1' DIMENSIONS ARE DETERMINED AT DATUM H.
- DIMENSION 'b' DOES NOT INCLUDE DAMBAR PROTRUSION. ALLOWABLE DAMBAR PROTRUSION SHALL BE 0.10mm TOTAL IN EXCESS OF THE 'b' DIMENSION AT MAXIMUM MATERIAL CONDITION. THE DAMBAR CANNOT BE LOCATED ON THE LOWER RADIUS OF THE FOOT.

4.2 USON-8L 3x2mm, package code ZR

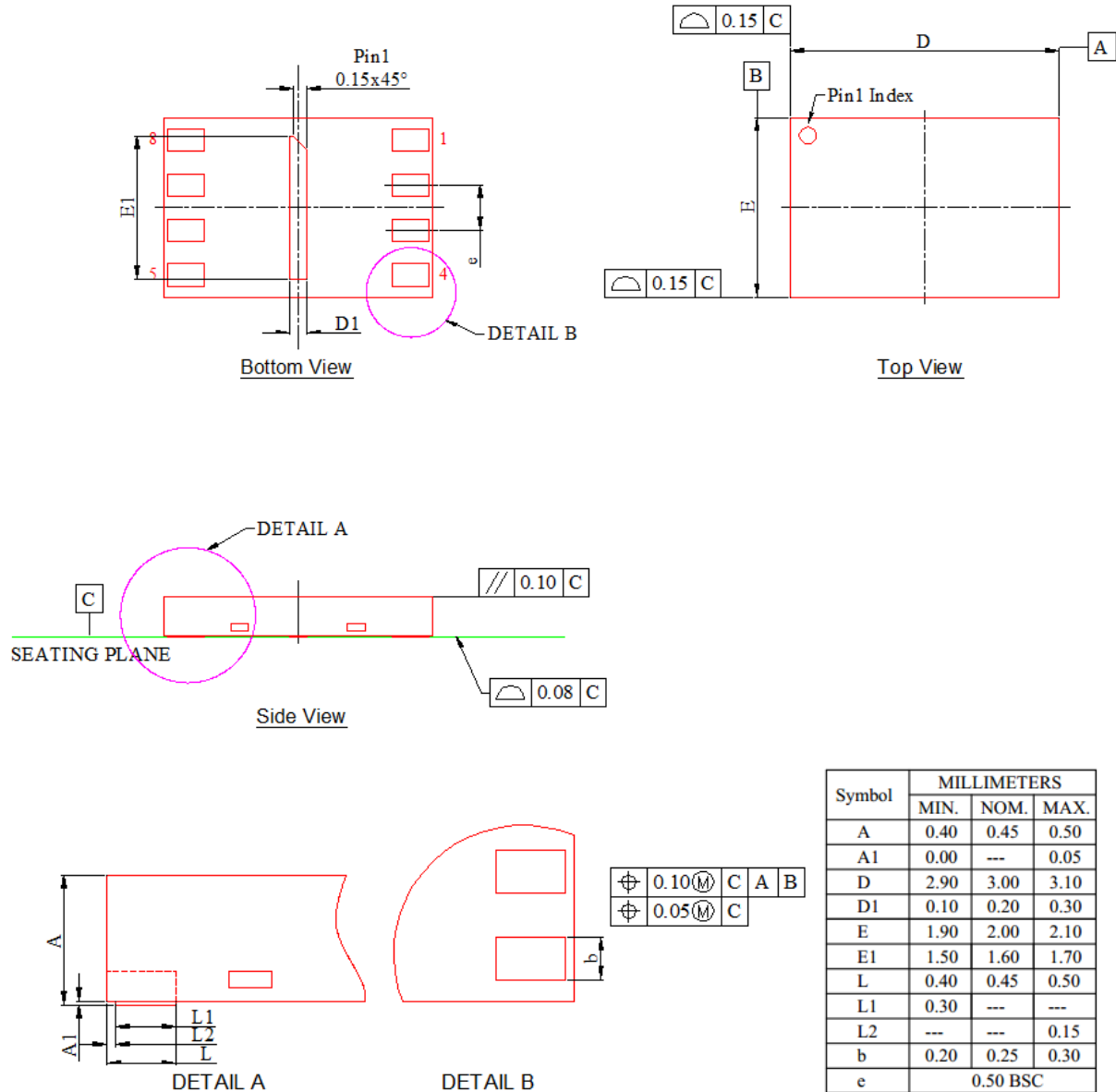

NOTE:

1. Scale 1:4
2. ALL DIMENSIONS AND TOLERANCES TAKE REFERENCE TO JEDEC MO-229
3. DIMENSION "b" APPLIES TO METALLIZED TERMINAL AND IS MEASURED BETWEEN 0.15MM AND 0.30MM FROM THE TERMINAL TIP. IF THE TERMINAL HAS OPTIONAL RADIUS ON THE OTHER END OF THE TERMINAL, THE DIMENSION B SHOULD NOT BE MEASURED IN THAT RADIUS AREA.

5 Ordering Information

Table 1: Ordering Information

Part Number	Temperature Range	Max Frequency	Note
APS6404L-3SQR-ZR	Tc = -25°C to +85°C	133 MHz*	USON-8
APS6404L-3SQR-SN	Tc = -40°C to +85°C	133 MHz*	SOP-8
APS6404L-3SQRX-SN	Tc = -40°C to +105°C	133 MHz*	SOP-8

Note *: 133MHz for 32 Bytes Wrapped Burst operation at VDD=3.0V+/-10%
 109MHz for 32 Bytes Wrapped Burst operation at VDD=3.3V+/-10%
 84MHz for Linear Burst operation with RBX(row boundary crossing)

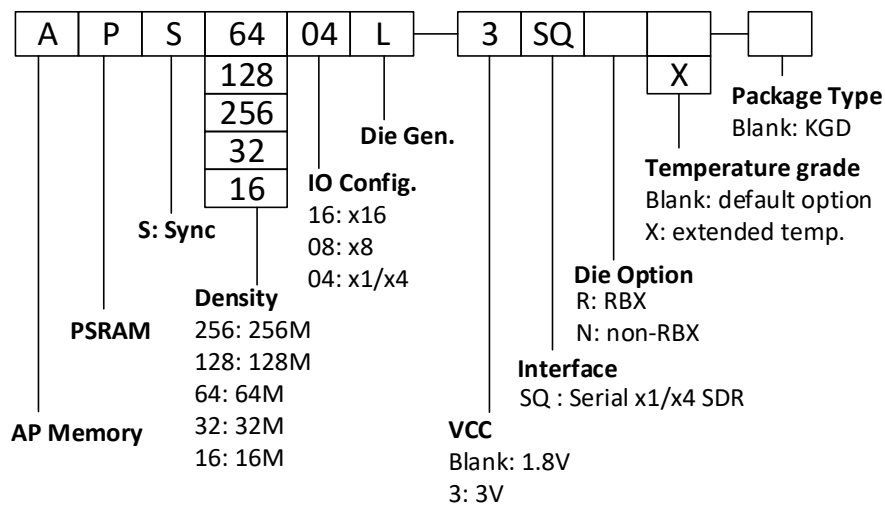

6 Signal Table

All signals are listed in Table 2.

Table 2: Signals Table

Symbol	Type	SPI Mode Function		QPI Mode Function	Comments	
VDD	Power	Core supply				
VSS	Ground	Core supply ground				
CE#	Input	Chip select, active low. When CE#=1, chip is in standby state				
CLK	Input	Clock Signal				
SI/SIO[0]	IO	Serial Input	IO[0]*	IO[0]		
SO/SIO[1]	IO	Serial Output	IO[1]*	IO[1]		
SIO[2]	IO	--	IO[2]*	IO[2]		
SIO[3]	IO	--	IO[3]*	IO[3]		

Note *: SPI Quad mode

7 Power-Up Initialization

SPI/QPI products include an on-chip voltage sensor used to start the self-initialization process. When VDD reaches a stable level at or above minimum VDD, the device will require 150 μ s and user-issued RESET Operation (see section 12) to complete its self-initialization process. From the beginning of power ramp to the end of the 150 μ s period, CLK should remain LOW, CE# should remain HIGH (track VDD within 200mV) and SI/SO/SIO[3:0] should remain LOW.

After the 150 μ s period the device is ready for normal operation.

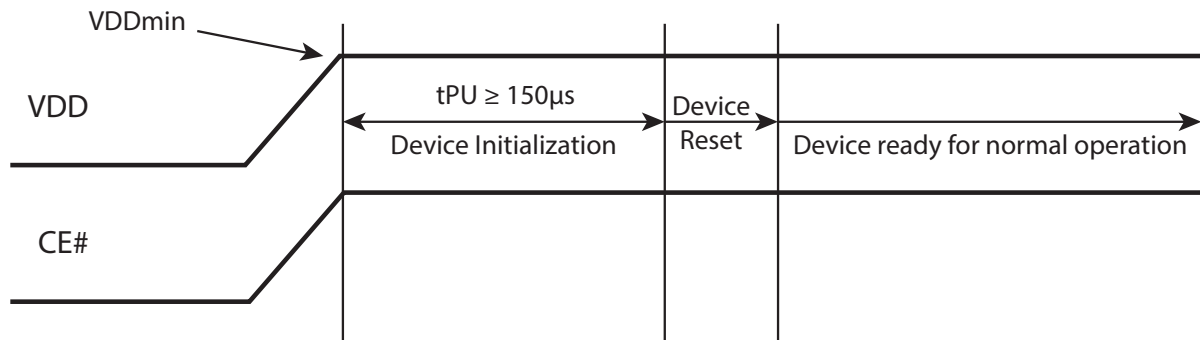

Figure 1. Power-Up Initialization Timing

8 Interface Description

8.1 Address Space

SPI/QPI PSRAM device is byte-addressable. 64M device is addressed with A[22:0].

8.2 Page Size

Page size is 1K (CA[9:0]). Default burst setting is Linear Bursting that crosses page boundary in a continuous manner. Note however that burst operations which cross page boundary have a lower max input clock frequency of 84MHz, and it can cross page boundary one time only in a burst. Optionally the device can also be set to wrap 32 (CA[4:0]) via the Wrap Boundary Toggle command and is not allowed to cross page boundary in this configuration.

8.3 Drive Strength

The device powers up in 50Ω.

8.4 Power-on Status

The device powers up in SPI Mode. It is required to have CE# high before beginning any operations.

8.5 Command/Address Latching Truth Table

The device recognizes the following commands specified by the various input methods.

Command	Code	SPI Mode (QE=0)					QPI Mode (QE=1)				
		Cmd	Addr	Wait Cycle	DIO	Max Freq.	Cmd	Addr	Wait Cycle	DIO	Max Freq.
Read	'h03	S	S	0	S	33	N/A				
Fast Read	'h0B	S	S	8	S	133/84*	Q	Q	4	Q	66
Fast Read Quad	'hEB	S	Q	6	Q	133/84*	Q	Q	6	Q	133/84*
Write	'h02	S	S	0	S	133/84*	Q	Q	0	Q	133/84*
Quad Write	'h38	S	Q	0	Q	133/84*	same as 'h02				
Enter Quad Mode	'h35	S	-	-	-	133	N/A				
Exit Quad Mode	'hF5	N/A					Q	-	-	-	133
Reset Enable	'h66	S	-	-	-	133	Q	-	-	-	133
Reset	'h99	S	-	-	-	133	Q	-	-	-	133
Wrap Boundary Toggle	'hC0	S	-	-	-	133	Q	-	-	-	133
Read ID	'h9F	S	S	0	S	33	N/A				

Remark: S = Serial IO, Q = Quad IO

Note *: **Max Freq.** would be 133MHz at VDD=3.0V+/-10% and 109MHz at VDD= 3.3V+/-10%) under Wrap32 operation; **Max Freq.** would be 84MHz under Linear Burst operation. Please refer Section 9 for Wrap32 and Linear Burst operation.

8.6 Command Termination

All Reads & Writes must be completed by raising CE# high immediately afterwards in order to terminate the active command and set the device into standby. Not doing so will block internal refresh operations and cause memory failure.

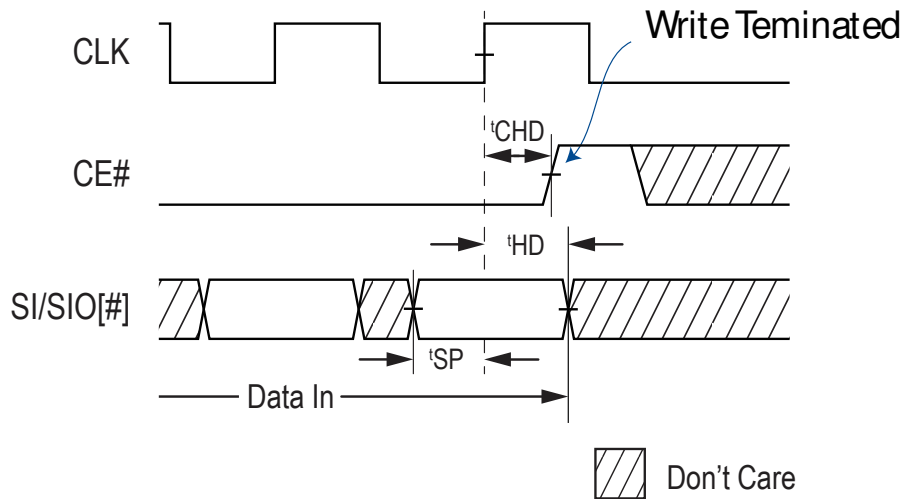

Figure 2: Write Command Termination

For a memory controller to correctly latch the last piece of data prior to read termination, it is recommended to provide a longer CE# hold time ($t_{\text{CHD}} > t_{\text{ACLK}} + t_{\text{CLK}}$) for a sufficient data window.

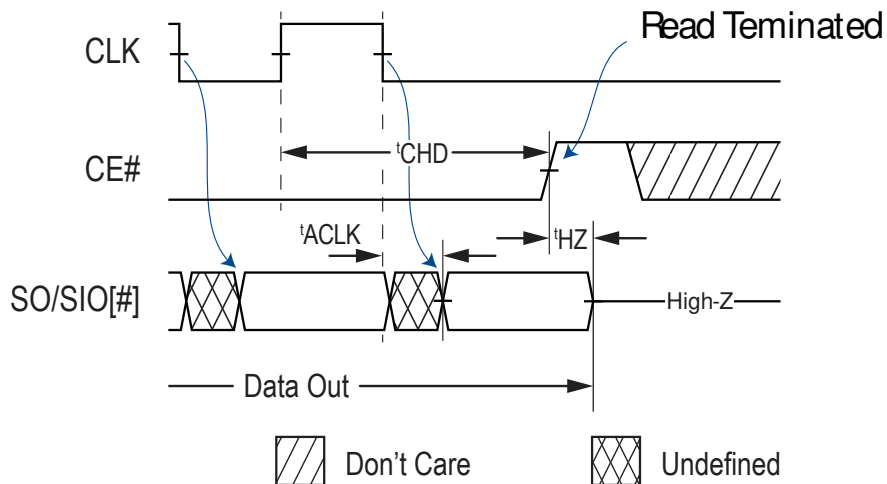

Figure 3: Read Command Termination

9 Wrap Boundary Toggle Operation

The Wrap Boundary Toggle Operation switches the device's wrapped boundary between Linear Burst which crosses the 1K page boundary (CA[9:0]) and Wrap 32 (CA[4:0]) bytes. Default setting is Linear Burst.

Linear Burst allows the device to burst through page boundary. Page boundary crossing is invisible to the memory controller and limited to a lower max CLK frequency of 84MHz.

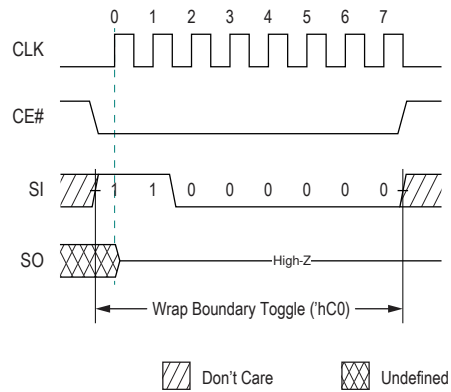

Figure 4: SPI Wrap Boundary Toggle 'hC0

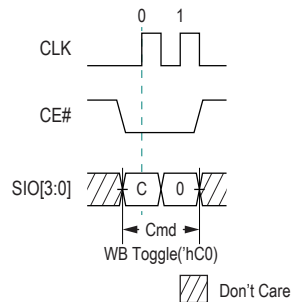

Figure 5: QPI Wrap Boundary Toggle 'hC0

Table 3: Wrapped Length:

Default	CMDs ('h03,'h0B,'hEB,'h02,'h38)	
Wrapped Length	Page Boundary Crossing enabled	Page Boundary Crossing disabled
Linear burst	Linear 1K cross page boundary	Wrap 1K
Wrap 32	Wrap 32	Wrap 32

10 SPI Mode Operations

The device powers up into SPI mode by default but can also be switched into QPI mode.

10.1 SPI Read Operations

For all reads, data will be available t^1_{ACLK} after the falling edge of CLK.

SPI Reads can be done in three ways with Linear Burst or 32 Bytes Wrapped Burst:

1. 'h03: Serial CMD, Serial Addr/IO, slow frequency
2. 'h0B: Serial CMD, Serial Addr/IO, fast frequency
3. 'hEB: Serial CMD, Quad Addr/IO, fast frequency

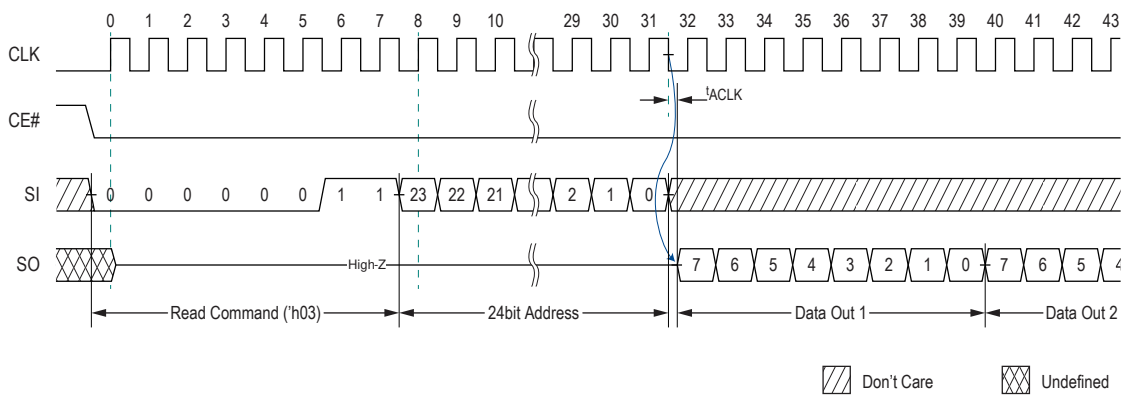

Figure 6: SPI Read 'h03 (max freq 33MHz)

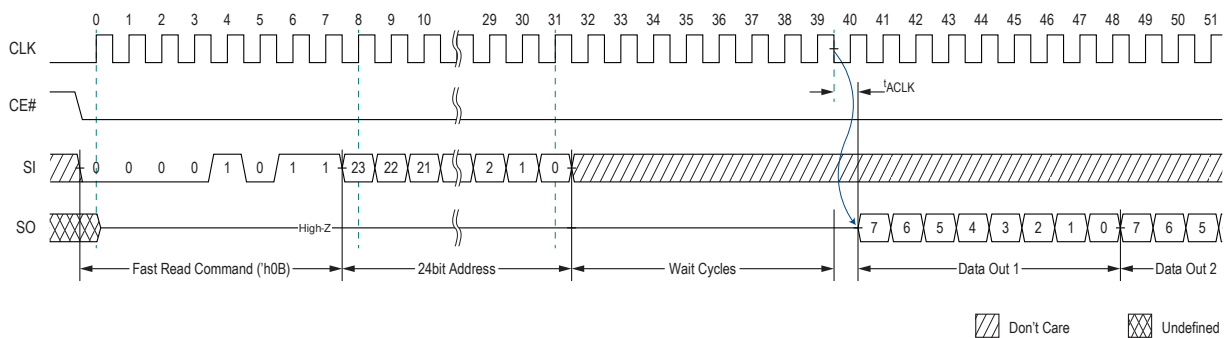

Figure 7: SPI Fast Read 'h0B (max freq 133 MHz)

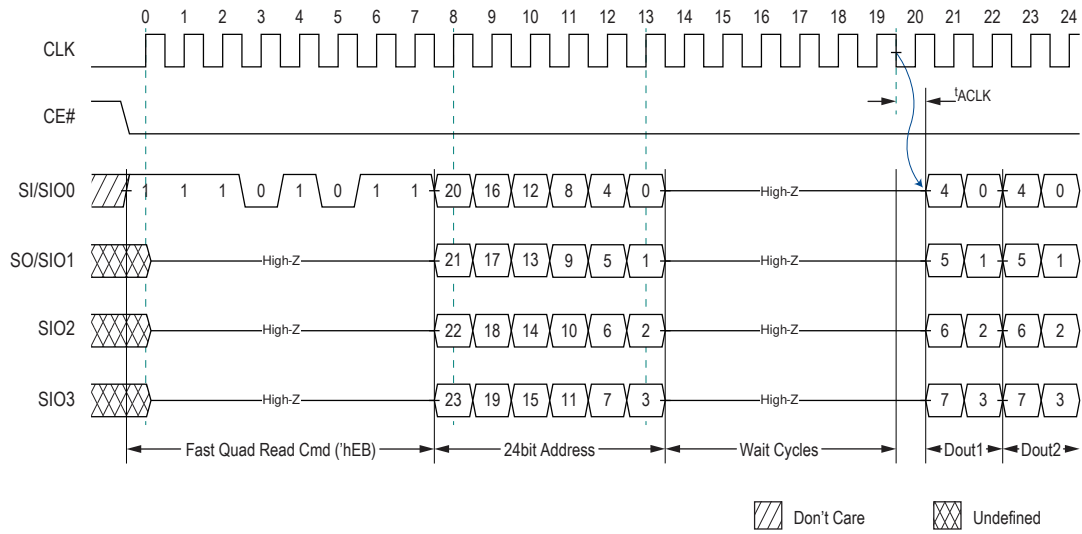

Figure 8: SPI Fast Quad Read 'hEB (max freq 133 MHz)

10.2 SPI Write Operations

SPI write command can be input as 'h02 or 'h38.

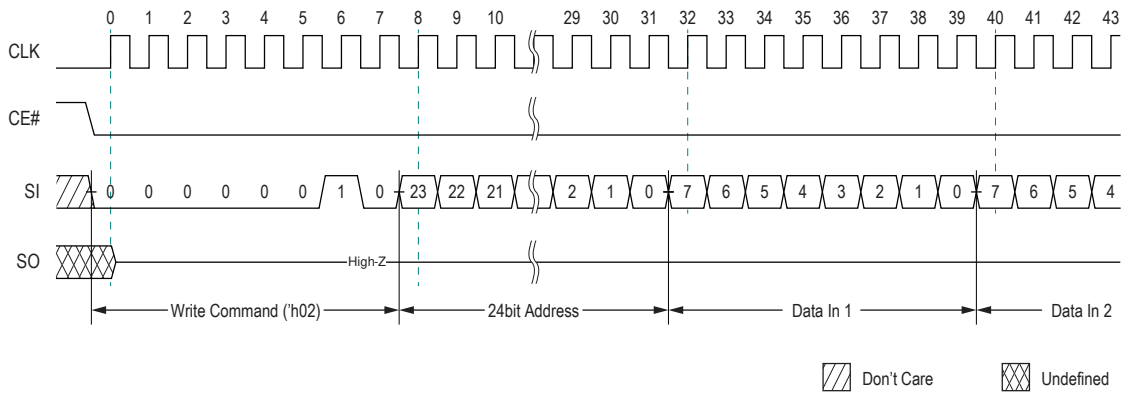

Figure 9: SPI Write 'h02

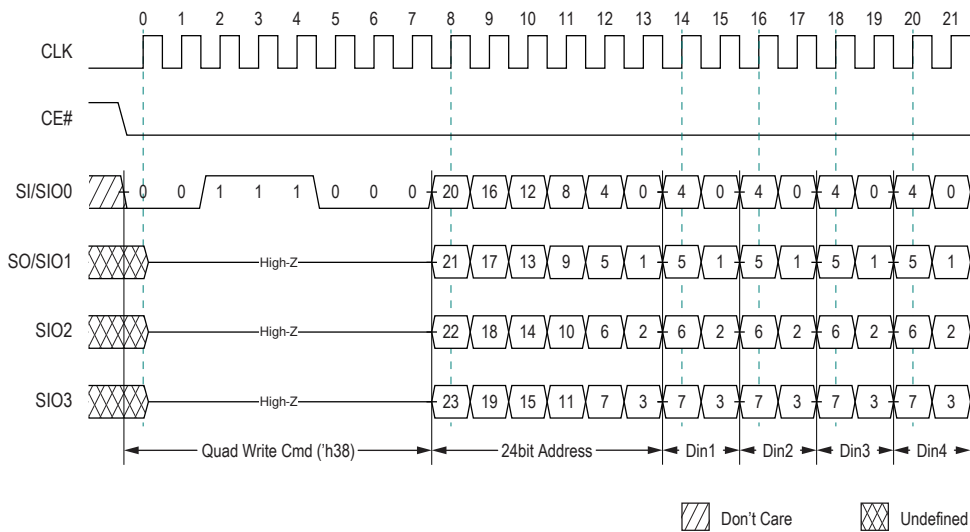

Figure 10: SPI Quad Write 'h38

10.3 SPI Quad Mode Enable Operation

This command switches the device into quad IO mode.

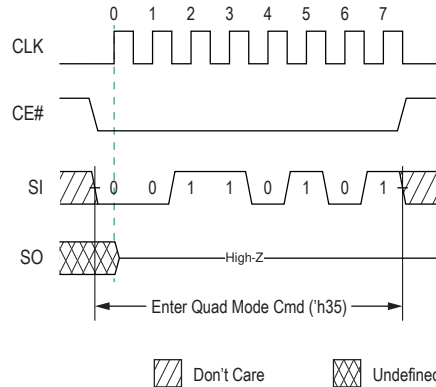

Figure 11: Quad Mode Enable 'h35 (available only in SPI mode)

10.4 SPI Read ID Operation

This command is similar to Fast Read, but without the wait cycles and the device outputs EID value instead of data.

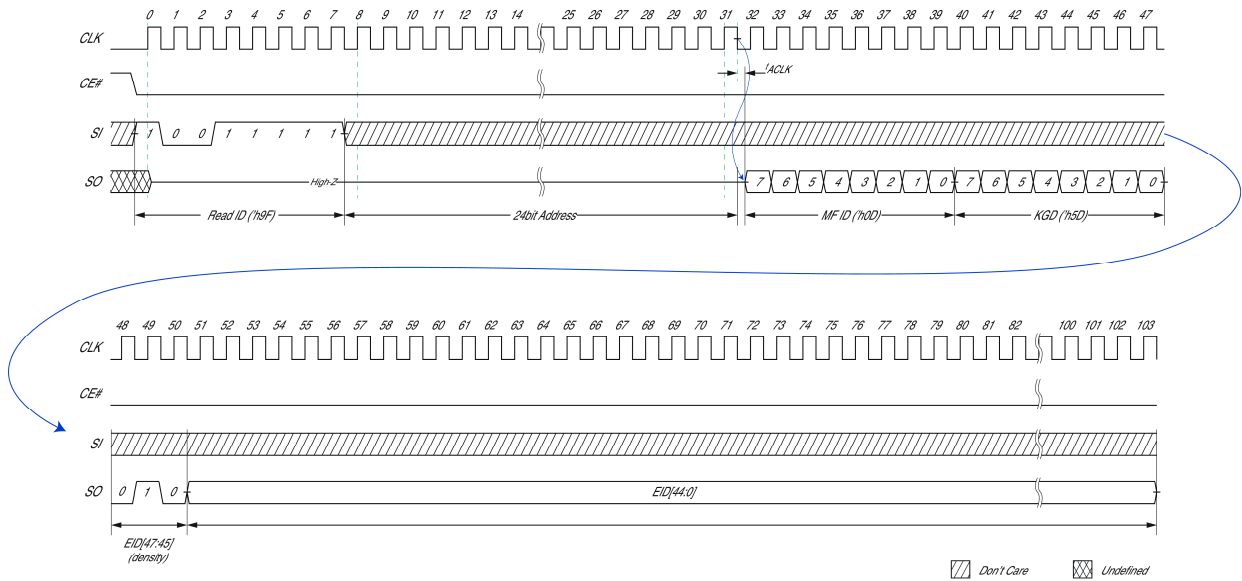

Figure 12: SPI Read ID 'h9F (available only in SPI mode)

Table 4: Known Good Die (KGD)

KGD[7:0]	Known Good Die
'b0101_0101	FAIL
'b0101_1101	PASS

*Note: Default is FAIL die, and only mark PASS after all tests passed.

11 QPI Mode Operations

11.1 QPI Read Operation

For all reads, data will be available t^{ACLK} after the falling edge of CLK.

QPI Reads can be done in one of two ways with Linear Burst or 32 Bytes Wrapped Burst:

1. 'h0B: Quad CMD, Quad Addr/IO, slow frequency
2. 'hEB: Quad CMD, Quad Addr/IO, fast frequency

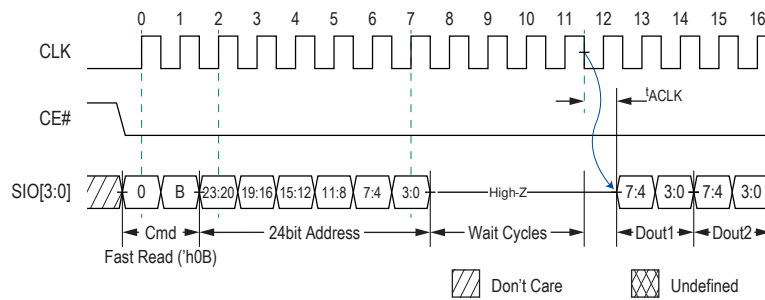

Figure 13: QPI Fast Read 'h0B (max freq 66 MHz)

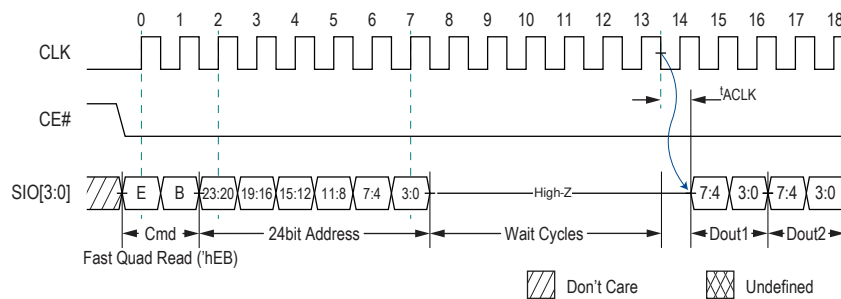

Figure 14: QPI Fast Quad Read 'hEB (max freq 133 MHz)

11.2 QPI Write Operation(s)

QPI write command can be input as 'h02 or 'h38.

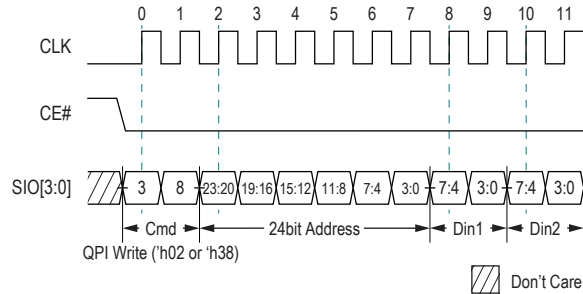

Figure 15: QPI Write 'h02 or 'h38

11.3 QPI Quad Mode Exit operation

This command will switch the device back into serial IO mode.

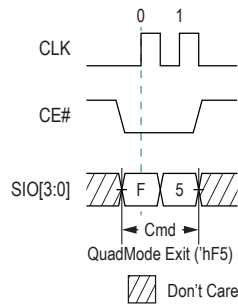

Figure 16: Quad Mode Exit 'hF5 (only available in QPI mode)

12 Reset Operation

The Reset operation is used as a system (software) reset that puts the device in SPI standby mode which is also the default mode after power-up. This operation consists of two commands: Reset-Enable (RSTEN) and Reset (RST).

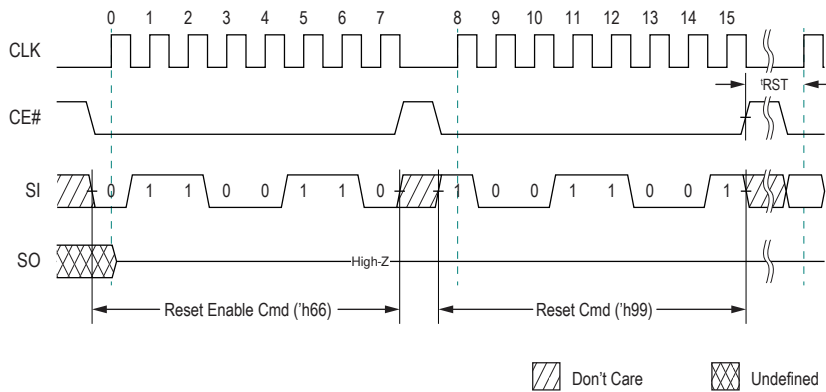

Figure 17: SPI Reset

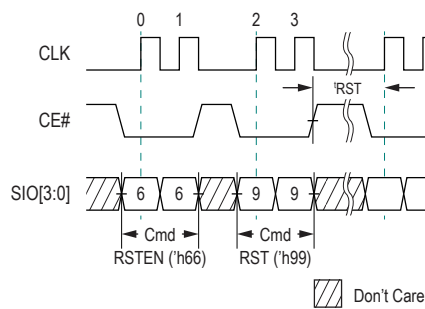

Figure 18: QPI Reset

Reset command has to immediately follow the Reset-Enable command in order for the reset operation to take effect. Any command other than the Reset command after the Reset-Enable command will cause the device to exit Reset-Enable state and abandon reset operation.

13 Input/Output Timing

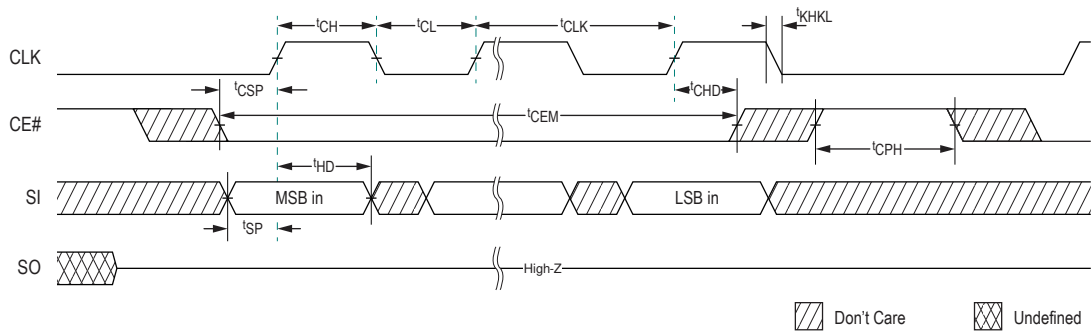

Figure 19: Input Timing

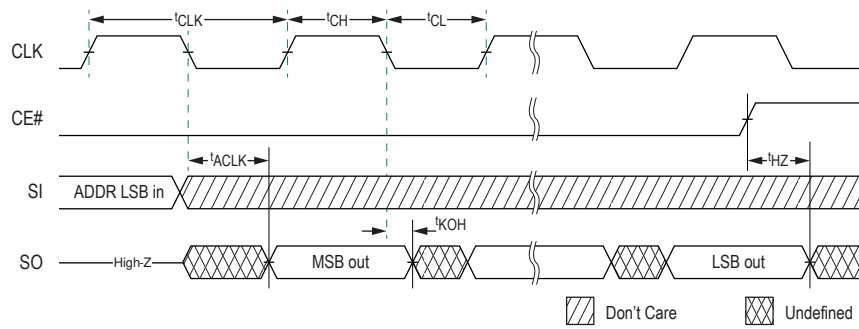

Figure 20: Output Timing

14 Electrical Specifications:

14.1 Absolute Maximum Ratings

Table 5: Absolute Maximum Ratings

Parameter	Symbol	Rating	Unit	Notes
Voltage to any ball except V_{DD} relative to V_{SS}	VT	-0.4 to $V_{DD}+0.4$	V	
Voltage on V_{DD} supply relative to V_{SS}	V_{DD}	-0.4 to +4.0	V	2
Storage Temperature	T_{STG}	-55 to +150	°C	1

Notes 1: Storage temperature refers to the case surface temperature on the center/top side of the PSRAM.

Notes 2: During voltage transitions, all pins may overshoot to -0.5V or $V_{CC}+0.5V$ for period up to 20ns.

Caution:

Exposing the device to stress above those listed in Absolute Maximum Ratings could cause permanent damage. The device is not meant to be operated under conditions outside the limits described in the operational section of this specification. Exposure to Absolute Maximum Rating conditions for extended periods may affect device reliability.

14.2 Pin Capacitance

Table 6: Package Pin Capacitance

Parameter	Symbol	Min	Max	Unit	Notes
Input Pin Capacitance	CIN		6	pF	VIN=0V
Output Pin Capacitance	COUT		8	pF	VOUT=0V

Note 1: spec'd at 25°C.

Table 7: Load Capacitance

Parameter	Symbol	Min	Max	Unit	Notes
Load Capacitance	C_L		15	pF	

Note 1: System C_L for the use of package

14.3 Decoupling Capacitor Requirement

It is required to have a decoupling capacitor on VDD pin for IO switchings and psram internal transient events. A low ESR 1 μ F ceramic cap is recommended. To minimize parasitic inductance, place the cap as close to VDD pin as possible. An optional 0.1 μ F can further improve high frequency transient response.

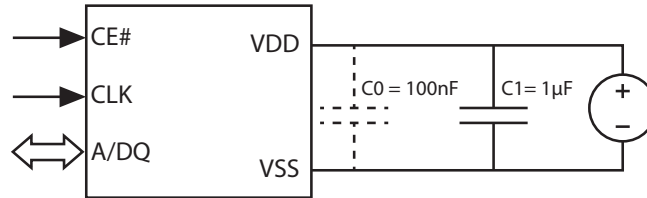

14.4 Operating Conditions

Table 8: Operating Characteristics

Parameter	Min	Max	Unit	Notes
Operating Temperature (extended)	-40	105	°C	1
Operating Temperature (standard)	-40(-25*)	85	°C	*USON package ZR

Note 1: spec'd temp range of -40 to 105°C is only characterized; test condition will be -32 to 105°C.

14.5 DC Characteristics

Table 9: DC Characteristics

Symbol	Parameter	Min	Max	Unit	Notes
V _{DD}	Supply Voltage	2.7	3.6	V	
V _{IH}	Input high voltage	V _{DD} -0.4	V _{DD} +0.2	V	
V _{IL}	Input low voltage	-0.2	0.4	V	
V _{OH}	Output high voltage (I _{OH} =-0.2mA)	0.8 V _{DD}		V	
V _{OL}	Output low voltage (I _{OL} =+0.2mA)		0.2 V _{DD}	V	
I _{LI}	Input leakage current		1	μA	
I _{LO}	Output leakage current		1	μA	
I _{CC}	Read/Write		7	mA	1,2
ISB _{EXT}	Standby current (extended temp)		350	μA	3
ISB _{STD}	Standby current (standard temp)		250	μA	3
ISB _{STDroom}	Standby current (standard room temp)		140	μA	3,4

- Note
- 1: Output load current not included.
 2. **Typical I_{CC} 5.5mA at 133MHz**
 3. Standby current is measured when CLK is in DC low state.
 4. **Typical ISB_{STDroom} 100uA**

14.6 AC Characteristics

Table 10: READ/WRITE Timing

Symbol	Parameter	Min	Max	Unit	Notes
t ^{CLK}	CLK period - SPI Read ('h03)	30.3		ns	33MHz
	CLK period - QPI Read ('h0B)	15.1			66MHz
	CLK period - all other operations PKG 3V	7.5			133MHz ^{*1,2,3}
	CLK period - all other operations PKG 3.3V	9.17			109MHz ^{*2,3}
	CLK period - all other operations	11.9			84MHz ^{*1}
t ^{CH} /t ^{CL}	Clock high/low width	0.45	0.55	t ^{CLK} (min)	
t ^{KHKL}	CLK rise or fall time		1.5	ns	4
t ^{CPH}	CE# HIGH between subsequent burst operations	18		ns	
t ^{CEM}	CE# low pulse width		4	μs	Extended grade
			8		Standard grade
t ^{CSP}	CE# setup time to CLK rising edge PKG	2.5		ns	
t ^{CHD}	CE# hold time from CLK rising edge PKG	3.0		ns	2
t ^{SP}	Setup time to active CLK edge	2		ns	
t ^{HD}	Hold time from active CLK edge	2		ns	
t ^{HZ}	Chip disable to DQ output high-Z		5.5	ns	
t ^{ACLK}	CLK to output delay	2	5.5	ns	
t ^{KOH}	Data hold time from clock falling edge	1.5		ns	
t ^{RST}	Time between end of RST CMD to next valid CMD	50		ns	

Note 1: Only Linear Burst allows page boundary crossing. Frequency limits are therefore 133MHz (PKG VDD= 3.0V+-10%), 109MHz(PKG VDD= 3.3V+-10%) max for Wrap 32 Bytes, and 84MHz for Linear Burst commands cross page boundary

2: System max C_L 15pF for the use of package.

3: For operating frequencies >84MHz, it is highly recommended to utilize CLK falling edge to sample read data or align sampling clock via data pattern tuning (refer to JEDEC JESD84-B50 for an example).

4: Measured from 20% to 80% of VDD

15 Change Log

Version	Date	Description
0.1	Jul 13, 2017	Initial Version
1.1	July 25, 2017	Revised package code and ordering information
1.2	Aug 24, 2017	Corrected package code; Added system max C_L for the use of package & related tCK and tCHD
1.3	Sep 04, 2017	Added ISBstdroom
1.5	Oct 30, 2017	Enabled QPI Read 'h0B support; changed Min/Max absolute voltage, V_{il_min} and V_{ih_max} ; defined tCEM for different temperature grade; corrected speed typo. Added USON package ZR
1.6	Nov 13, 2017	Modified spec of ICC & ISB
1.7	Mar 19, 2018	Revised part# of RBX. Temperature -40C
1.8	Jan 07, 2019	Remove WSON and updated POD of USON, add tRST
1.9	Sep 05, 2019	Updated Figure 12, Table 7 and Table 9; Added table for Change Log; updated section 8.5 and 14.6; added section 14.3
2.0a	Oct 02, 2019	Updated header, page 1 and Table 1
2.1	Oct 25, 2019	Revised the typo in page 12 and 16; update Table 3, Figure 17 and Figure 18
2.2	Nov 21, 2019	Update Table 2, Figure 10 and Figure 15
2.3	Apr 30, 2020	Modify VDD's description of Table 2