

CA-IS376x High-Speed Six-Channel Digital Isolators

1. Features

- **Robust Galvanic Isolation of Digital Signals**
 - High lifetime: >40 years
 - Up to 5000 V_{RMS} isolation rating (narrow body packages) and up to 5000 V_{RMS} isolation rating (wide body packages)
 - ±150 kV/μs typical CMTI
 - Wide operating temperature range: -40°C to 125°C
 - Schmitt trigger inputs
- **Interfaces Directly with Most MCUs and FPGAs**
 - Data rate: DC to 150Mbps
 - Accepts 2.5V to 5.5V supplies
 - Default output *High* (CA-IS376xH) and *Low* (CA-IS376xL) Options
- **Low Power Consumption**
 - 1.5mA per channel at 1Mbps with V_{DD} = 5.0V
 - 6.6mA per channel at 100Mbps with V_{DD} = 5.0V
- **Best in class propagation delay and skew**
 - 12ns typical propagation delay
 - 1ns pulse width distortion
 - 2ns propagation delay skew (chip -to-chip)
 - 5ns minimum pulse width
- **No Start-Up Initialization Required**
- **Package Options**
 - Narrow-body SOIC16-NB(N) package
 - Wide-body SOIC16-WB(W) package
- **Safety Regulatory Approvals**
 - VDE 0884-11 isolation certification
 - UL According to UL1577
 - IEC 62368-1, IEC 61010-1, GB 4943.1-2011 and GB 8898-2011 certifications

2. Applications

- Industrial Automation
- Motor Control
- Medical Systems
- Isolated Power Supplies
- Solar Inverters
- Isolated ADC,DAC

3. General Description

The CA-IS376x devices are high-performance six-channel, unidirectional digital isolators with up to 3.75kV_{RMS} (narrow-body package) or 5kV_{RMS} (wide-body package) isolation rating and ultra-fast data rate. The CA-IS376x devices offer high electromagnetic immunity and low emissions at low power consumption while isolating different ground domains and block high-voltage/high-current transients from sensitive or human interface circuitry. Each isolation channel has a logic input and output buffer separated by capacitive silicon dioxide (SiO₂) insulation barrier, the integrated Schmitt trigger on each input provide excellent noise immunity.

The CA-IS376x family offers all possible unidirectional channel configurations to accommodate any 6-channel design digital I/O applications, especial for the multiple SPI devices isolation. The CA-IS3760 features six channels transferring digital signals in one direction; The CA-IS3761 device has five forward and one reverse-direction channels; The CA-IS3762 device offers four forward and two reverse-direction channels isolation; The CA-IS3763 provides further design flexibility with three channels in each direction. All devices of this family features default outputs. When the input is either not powered or is open-circuit, the default output is low for devices with suffix L and high for devices with suffix H, see the *Ordering Information* for suffixes associated with each option.

The CA-IS376x series devices are specified over the -40°C to +125°C operating temperature range and are available in 16-pin SOIC narrow body package and 16-pin SOIC wide body package.

Device information

Part number	Package	Package size (NOM)
CA-IS3760	SOIC16-NB (N)	9.90 mm × 3.90 mm
CA-IS3761		
CA-IS3762	SOIC16-WB(W)	10.30 mm × 7.50 mm
CA-IS3763		

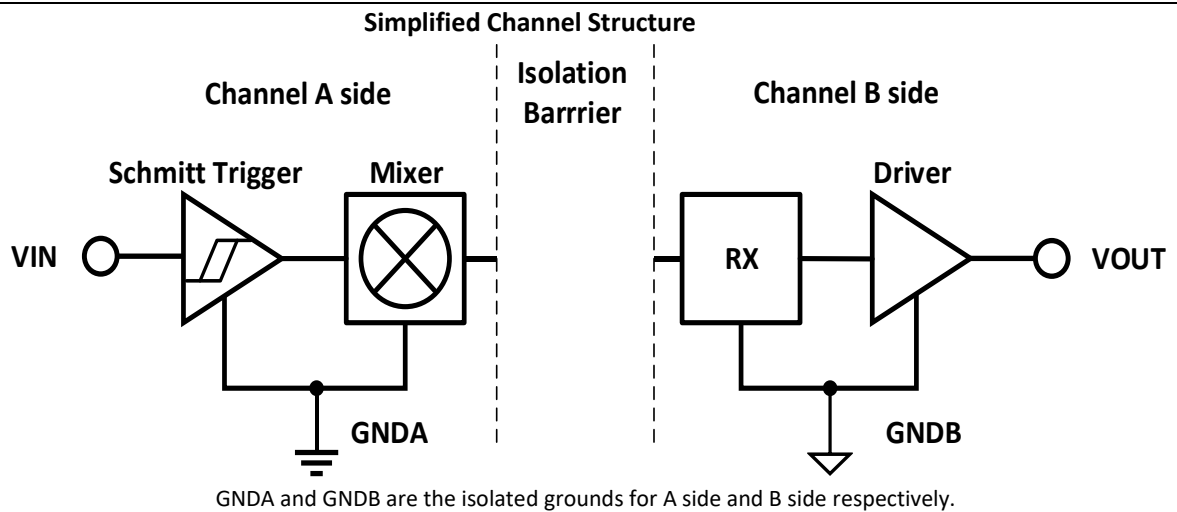

4. Ordering Information

Table 4-1. Ordering Information

Part Number	Number of Inputs A Side	Number of Inputs B Side	Default Output	Isolation Rating (kV)	Output Enable	Package
CA-IS3760LN	6	0	Low	3.75	No	SOIC16-NB
CA-IS3760LW	6	0	Low	5.0	No	SOIC16-WB
CA-IS3760HN	6	0	High	3.75	No	SOIC16-NB
CA-IS3760HW	6	0	High	5.0	No	SOIC16-WB
CA-IS3761LN	5	1	Low	3.75	No	SOIC16-NB
CA-IS3761LW	5	1	Low	5.0	No	SOIC16-WB
CA-IS3761HN	5	1	High	3.75	No	SOIC16-NB
CA-IS3761HW	5	1	High	5.0	No	SOIC16-WB
CA-IS3762LN	4	2	Low	3.75	No	SOIC16-NB
CA-IS3762LW	4	2	Low	5.0	No	SOIC16-WB
CA-IS3762HN	4	2	High	3.75	No	SOIC16-NB
CA-IS3762HW	4	2	High	5.0	No	SOIC16-WB
CA-IS3763LN	3	3	Low	3.75	No	SOIC16-NB
CA-IS3763LW	3	3	Low	5.0	No	SOIC16-WB
CA-IS3763HN	3	3	High	3.75	No	SOIC16-NB
CA-IS3763HW	3	3	High	5.0	No	SOIC16-WB

Contents

1. Features	1	7.9. Supply Current Characteristics	10
2. Applications	1	7.10. Timing Characteristics	13
3. General Description	1	8. Parameter Measurement Information	14
4. Ordering Information	2	9. Detailed Description	16
5. Revision History	3	9.1. Overview	16
6. Pin Configuration and Description	4	9.2. Functional Block Diagram	16
7. Specifications	5	9.3. Device Operation Modes	16
7.1. Absolute Maximum Ratings ¹	5	10. Application and Implementation	17
7.2. ESD Ratings.....	5	11. Package Information	19
7.3. Recommended Operating Conditions	5	11.1. 16-Pin Wide Body SOIC Package Outline	19
7.4. Thermal Information	5	11.2. 16-Pin Narrow Body SOIC Package Outline.....	20
7.5. Power Rating	6	12. Soldering Temperature (reflow) Profile	21
7.6. Insulation Specifications	7	13. Tape and Reel Information	22
7.7. Safety-Related Certifications	8	14. Important statement	23
7.8. Electrical Characteristics	9		

5. Revision History

Revision Number	Description	Revision date	Page Changed
Version 1.0	N/A		N/A
Version 1.01	Changed V_{IORM} to 1414V, changed V_{IOWM} AC RMS value to 1000V and DC value to 1414V. Updated Power Ratings table.		7, 11, 12, 13
Version 1.02	$V_{IT+(IN)}$ min value updated to 2V, $V_{IT-(IN)}$ max value updated to 0.8V and removed $V_{I(HYS)}$.		9
Version 1.03	Description of $V_{IT+(IN)}$ changed to High-level Input Voltage, description of $V_{IT-(IN)}$ changed to Low-level Input Voltage.		9
Version 1.04	Revised POD and tape reel information	2022/12/15	19,22

6. Pin Configuration and Description

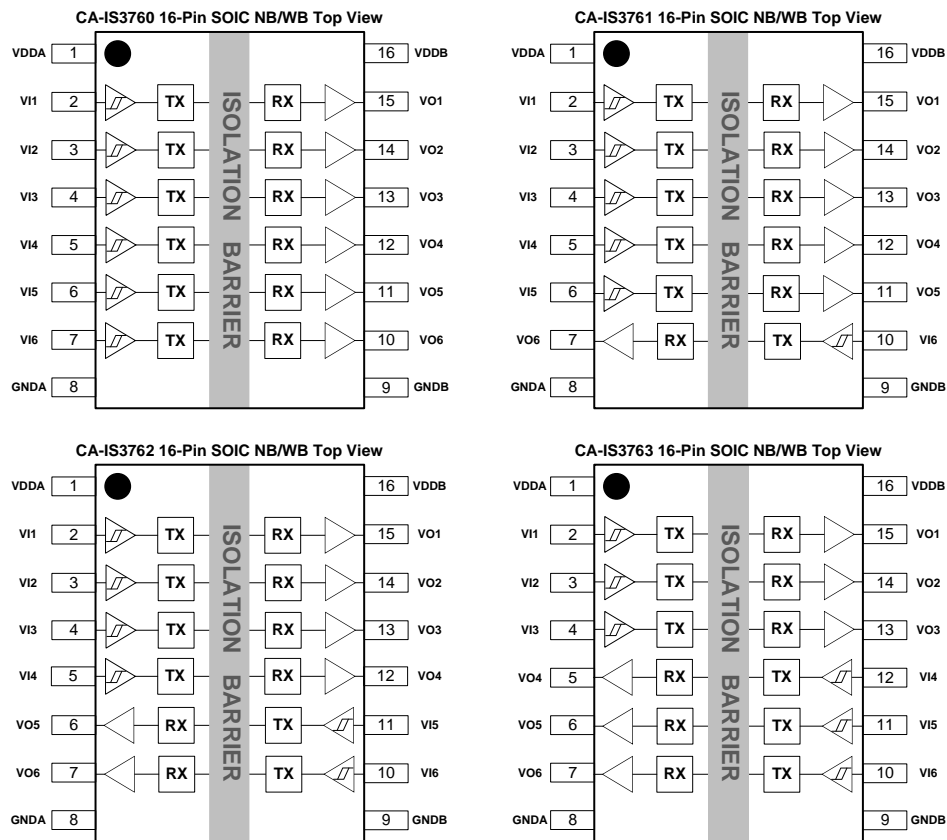

Figure 6-1. CA-IS376x pin configuration

Table 6-1. CA-IS376x pin description

16-SOIC Pin#				Name	Type	Description
CA-IS3760	CA-IS3761	CA-IS3762	CA-IS3763			
1	1	1	1	VDDA	Supply	Power supply for side A.
2	2	2	2	VI1	Digital I/O	Digital input 1 on side A, corresponds to logic output 1 on side B.
3	3	3	3	VI2	Digital I/O	Digital input 2 on side A, corresponds to logic output 2 on side B.
4	4	4	4	VI3	Digital I/O	Digital input 3 on side A, corresponds to logic output 3 on side B.
5	5	5	12	VI4	Digital I/O	Digital input 4 on side A/B, corresponds to logic output 4 on side B/A.
6	6	11	11	VI5	Digital I/O	Digital input 5 on side A/B, corresponds to logic output 5 on side B/A.
7	10	10	10	VI6	Digital I/O	Digital input 6 on side A/B, corresponds to logic output 6 on side B/A.
8	8	8	8	GNDA	Ground	Ground reference for side A.
9	9	9	9	GNDB	Ground	Ground reference for side B.
10	7	7	7	VO6	Digital I/O	Digital output 6 on side B/A, VO6 is the logic output for the VI6 input on side A/B.
11	11	6	6	VO5	Digital I/O	Digital output 5 on side B/A, VO5 is the logic output for the VI5 input on side A/B.
12	12	12	5	VO4	Digital I/O	Digital output 4 on side B/A, VO4 is the logic output for the VI4 input on side A/B.
13	13	13	13	VO3	Digital I/O	Digital output 3 on side B, VO3 is the logic output for the VI3 input on side A.
14	14	14	14	VO2	Digital I/O	Digital output 2 on side B, VO2 is the logic output for the VI2 input on side A.
15	15	15	15	VO1	Digital I/O	Digital output 1 on side B, VO1 is the logic output for the VI1 input on side A.
16	16	16	16	VDDB	Supply	Power supply for side B.

7. Specifications

7.1. Absolute Maximum Ratings¹

Parameters		Minimum value	Maximum value	Unit
V _{DDA} , V _{DDB}	Power supply voltage ²	-0.5	7.0	V
V _{IN}	Voltage at V _{Ix} , V _{Ox} , EN _x	-0.5	V _{DD_} + 0.5 ³	V
I _O	Output current	-20	20	mA
T _J	Junction temperature		150	°C
T _{STG}	Storage temperature range	-65	150	°C

Notes:

- The stresses listed under “Absolute Maximum Ratings” are stress ratings only, not for functional operation condition. Exposure to absolute maximum rating conditions for extended periods may cause permanent damage to the device.
- All voltage values except differential I/O bus voltages are with respect to the local ground terminal (GNDA or GNDB) and are peak voltage values.
- Maximum voltage must not be exceed 7 V.

7.2. ESD Ratings

		Numerical value	Unit
V _{ESD} Electrostatic discharge	Human body model (HBM), per ANSI/ESDA/JEDEC JS-001, all pins ¹	±6000	V
	Charged device model (CDM), per JEDEC Specification JESD22-C101, all pins ²	±2000	

Notes:

- Per JEDEC document JEP155, 500V HBM allows safe manufacturing of standard ESD control process.
- Per JEDEC document JEP157, 250V HBM allows safe manufacturing of standard ESD control process.

7.3. Recommended Operating Conditions

PARAMETER		MIN	TYPE	MAX	UNIT
V _{DDA} , V _{DDB}	Supply voltage on side A, B	2.375	3.30	5.50	V
V _{DD(UVLO+)}	V _{DD} Under-voltage-Lockout Threshold When Supply Voltage is Rising	1.95	2.24	2.375	V
V _{DD(UVLO-)}	V _{DD} Under-voltage-Lockout Threshold When Supply Voltage is Falling	1.88	2.10	2.325	V
V _{HYS(UVLO)}	V _{DD} Under-voltage-Lockout Threshold Hysteresis	70	140	250	mV
I _{OH}	High-level Output Current	V _{DDO} ¹ = 5V	-4		mA
		V _{DDO} = 3.3V	-2		
		V _{DDO} = 2.5V	-1		
I _{OL}	Low-level Output Current	V _{DDO} = 5V		4	mA
		V _{DDO} = 3.3V		2	
		V _{DDO} = 2.5V		1	
V _{IH}	High-level Input Voltage	2.0			V
V _{IL}	Low-level Input Voltage			0.8	V
DR	Data Rate	0		150	Mbps
T _A	Ambient Temperature	-40	27	125	°C

Note:

- V_{DDO} = Output-side supply V_{DD}.

7.4. Thermal Information

Thermal Metric	CA-IS376x		Unit	
	SOIC16-NB(N)	SOIC16-WB(W)		
R _{θJA}	Junction-to-ambient thermal resistance	96.2	83.4	°C/W

7.5. Power Rating

Parameters		Test conditions	MIN	TYPE	MAX	Unit
CA-IS3760						
P_D	Maximum Power Dissipation	$V_{DDA} = V_{DDB} = 5.5\text{ V}$, $C_L = 15\text{ pF}$, $T_J = 150^\circ\text{C}$, Input a 75-MHz 50% duty cycle square wave.			494	mW
P_{DA}	Maximum Power Dissipation on Side-A				49	mW
P_{DB}	Maximum Power Dissipation on Side-B				445	mW
CA-IS3761						
P_D	Maximum Power Dissipation	$V_{DDA} = V_{DDB} = 5.5\text{ V}$, $C_L = 15\text{ pF}$, $T_J = 150^\circ\text{C}$, Input a 75-MHz 50% duty cycle square wave.			494	mW
P_{DA}	Maximum Power Dissipation on Side-A				113	mW
P_{DB}	Maximum Power Dissipation on Side-B				381	mW
CA-IS3762						
P_D	Maximum Power Dissipation	$V_{DDA} = V_{DDB} = 5.5\text{ V}$, $C_L = 15\text{ pF}$, $T_J = 150^\circ\text{C}$, Input a 75-MHz 50% duty cycle square wave.			494	mW
P_{DA}	Maximum Power Dissipation on Side-A				180	mW
P_{DB}	Maximum Power Dissipation on Side-B				314	mW
CA-IS3763						
P_D	Maximum Power Dissipation	$V_{DDA} = V_{DDB} = 5.5\text{ V}$, $C_L = 15\text{ pF}$, $T_J = 150^\circ\text{C}$, Input a 75-MHz 50% duty cycle square wave.			494	mW
P_{DA}	Maximum Power Dissipation on Side-A				247	mW
P_{DB}	Maximum Power Dissipation on Side-B				247	mW

7.6. Insulation Specifications

Parameters		Test conditions	Value		Unit
			W	N	
CLR	External Clearance	Shortest terminal-to-terminal distance through air	8	4	mm
CPG	External Creepage	Shortest terminal-to-terminal distance across the package surface	8	4	mm
DTI	Distance through the insulation	Minimum internal gap (internal clearance)	24	24	μm
CTI	Comparative tracking index	DIN EN 60112 (VDE 0303-11); IEC 60112	>600	>600	V
	Material group	Per IEC 60664-1	I	I	
Overvoltage category per IEC 60664-1	Rated mains voltage ≤ 300 V _{RMS}		I-IV	I-III	
	Rated mains voltage ≤ 400 V _{RMS}		I-IV	I-III	
	Rated mains voltage ≤ 600 V _{RMS}		I-III	N/A	
DIN V VDE V 0884-11:2017-01¹					
V _{IORM}	Maximum repetitive peak isolation voltage	AC voltage (bipolar)	1414	566	V _{PK}
V _{IOWM}	Maximum operating isolation voltage	AC voltage; time-dependent dielectric breakdown (TDDb) test	1000	400	V _{RMS}
		DC voltage	1414	566	V _{DC}
V _{IOTM}	Maximum transient isolation voltage	V _{TEST} = V _{IOTM} , t = 60 s (certified); V _{TEST} = 1.2 × V _{IOTM} , t = 1 s (100% product test)	7070	5300	V _{PK}
V _{IOSM}	Maximum surge isolation voltage ²	Test method per IEC 60065, 1.2/50 μs waveform, V _{TEST} = 1.6 × V _{IOSM} (production test)	6250	5000	V _{PK}
Q _{pd}	Apparent charge ³	Method a, after input/output safety test of the subgroup 2/3, V _{ini} = V _{IOTM} , t _{ini} = 60 s; V _{pd(m)} = 1.2 × V _{IORM} , t _m = 10 s	≤5	≤5	pC
		Method a, after environmental test of the subgroup 1, V _{ini} = V _{IOTM} , t _{ini} = 60 s; V _{pd(m)} = 1.6 × V _{IORM} , t _m = 10 s	≤5	≤5	
		Method b, at routine test (100% production test) and preconditioning (type test) V _{ini} = 1.2 × V _{IOTM} , t _{ini} = 1 s; V _{pd(m)} = 1.875 × V _{IORM} , t _m = 1 s	≤5	≤5	
C _{IO}	Barrier capacitance, input to output ⁴	V _{IO} = 0.4 × sin(2πft), f = 1 MHz	~0.5	~0.5	pF
R _{IO}	Isolation resistance ⁴	V _{IO} = 500 V, T _A = 25°C	>10 ¹²	>10 ¹²	Ω
		V _{IO} = 500 V, 100°C ≤ T _A ≤ 125°C	>10 ¹¹	>10 ¹¹	
		V _{IO} = 500 V at T _S = 150°C	>10 ⁹	>10 ⁹	
	Pollution degree		2	2	
UL 1577					
V _{ISO}	Maximum withstanding isolation voltage	V _{TEST} = V _{ISO} , t = 60 s (qualification) V _{TEST} = 1.2 × V _{ISO} , t = 1 s (100% production test)	5000	3750	V _{RMS}
Notes:					
1. This coupler is suitable for “safe electrical insulation” only within the safety ratings. Compliance with the safety ratings shall be ensured by means of suitable protective circuits. 2. Devices are immersed in oil during surge characterization test. 3. The characterization charge is discharging charge (pd) caused by partial discharge. 4. Capacitance and resistance are measured with all pins on field-side and logic-side tied together.					

7.7. Safety-Related Certifications

VDE	UL	CQC	TUV
Certified according to DIN VDE V 0884-11:2017-01	Certified according to UL 1577 Component Recognition Program	Certified according to GB 4943.1-2011 and GB 8898-2011	Certified according to EN/IEC 61010-1:2010 (3rd Ed) and EN /IEC 62368-1:2014+A11:2017
Maximum transient isolation voltage: 7070V _{pk} (SOIC16-W), 5300V _{pk} (SOIC16-N)	SOP16-N: 3750 V _{RMS} ; SOP16-W: 5000 V _{RMS}	SOP16-N: Basic insulation, 400 V _{RMS} maximum working voltage; SOP16-W: Reinforced insulation, 1000 V _{RMS} maximum working voltage (Altitude ≤ 5000 m)	5000 V _{RMS} (SOP16-W) insulation and 3750V _{RMS} (SOP16-N) insulation per EN/IEC 61010-1:2010 (3rd Ed) and EN /IEC 62368-1:2014+A11:2017, working voltage is up to 1000 V _{RMS} (SOP16-W) and 400 V _{RMS} (SOP16-N)
Certificate number: 40052786	Certificate number : E511334-20200117	Certificate number SOP16-N: CQC20001251750 SOP16-W: CQC20001251466	CB Certificate number: JPTUV-111116; DE 2-027880 AK Certificate number: AK 50474784 0001; AK 50474786 0001

7.8. Electrical Characteristics
 $V_{DDA} = V_{DDB} = 5\text{ V} \pm 10\%$, $T_A = -40\text{ to }125^\circ\text{C}$ (over recommended operating conditions, unless otherwise specified)

Parameters		Test conditions	MIN	TYP	MAX	UNIT
V_{OH}	High-level Output Voltage	$I_{OH} = -4\text{mA}$; See 错误!未找到引用源。	$V_{DDO}^{1-0.4}$	4.8		V
V_{OL}	Low-level Output Voltage	$I_{OL} = 4\text{mA}$; See 错误!未找到引用源。		0.2	0.4	V
$V_{IT+(IN)}$	High-level Input Voltage		2			V
$V_{IT-(IN)}$	Low-level Input Voltage				0.8	V
I_{IH}	High-Level Input Leakage Current	$V_{IH} = V_{DDA}$ at INx or ENx			20	μA
I_{IL}	Low-Level Input Leakage Current	$V_{IL} = 0\text{ V}$ at INx	-20			μA
Z_O	Output Impedance ²			50		Ω
CMTI	Common-mode Transient Immunity	$V_I = V_{DDI}^1$ or 0 V, $V_{CM} = 1200\text{V}$; See 错误!未找到引用源。	100	150		$\text{kV}/\mu\text{s}$
C_i	Input Capacitance ³	$V_I = V_{DD}/2 + 0.4 \times \sin(2\pi ft)$, $f = 1\text{ MHz}$, $V_{DD} = 5\text{ V}$		2		pF

Notes:

- V_{DDI} = Input-side supply V_{DD} , V_{DDO} = Output-side supply V_{DD} .
- The nominal output impedance of each isolator driver is $50\ \Omega \pm 40\%$.
- Measured from pin to Ground.

 $V_{DDA} = V_{DDB} = 3.3\text{ V} \pm 10\%$, $T_A = -40\text{ to }125^\circ\text{C}$ (over recommended operating conditions, unless otherwise specified)

Parameters		Test conditions	MIN	TYP	MAX	UNIT
V_{OH}	High-level Output Voltage	$I_{OH} = -4\text{mA}$; See 错误!未找到引用源。	$V_{DDO}^{1-0.4}$	3.1		V
V_{OL}	Low-level Output Voltage	$I_{OL} = 4\text{mA}$; See 错误!未找到引用源。		0.2	0.4	V
$V_{IT+(IN)}$	Input logic High Voltage		2			V
$V_{IT-(IN)}$	Input logic Low Voltage				0.8	V
I_{IH}	High-Level Input Leakage Current	$V_{IH} = V_{DDA}$ at INx or ENx			20	μA
I_{IL}	Low-Level Input Leakage Current	$V_{IL} = 0\text{ V}$ at INx	-20			μA
Z_O	Output Impedance ²			50		Ω
CMTI	Common-mode Transient Immunity	$V_I = V_{DDI}^1$ or 0 V, $V_{CM} = 1200\text{V}$; See 错误!未找到引用源。	100	150		$\text{kV}/\mu\text{s}$
C_i	Input Capacitance ³	$V_I = V_{DD}/2 + 0.4 \times \sin(2\pi ft)$, $f = 1\text{ MHz}$, $V_{DD} = 3.3\text{ V}$		2		pF

Notes:

- V_{DDI} = Input-side supply V_{DD} , V_{DDO} = Output-side supply V_{DD} .
- The nominal output impedance of each isolator driver is $50\ \Omega \pm 40\%$.
- Measured from pin to Ground.

 $V_{DDA} = V_{DDB} = 2.5\text{ V} \pm 10\%$, $T_A = -40\text{ to }125^\circ\text{C}$ (over recommended operating conditions, unless otherwise specified)

Parameters		Test conditions	MIN	TYP	MAX	UNIT
V_{OH}	High-level Output Voltage	$I_{OH} = -4\text{mA}$; See 错误!未找到引用源。	$V_{DDO}^{1-0.4}$	2.3		V
V_{OL}	Low-level Output Voltage	$I_{OL} = 4\text{mA}$; See 错误!未找到引用源。		0.2	0.4	V
$V_{IT+(IN)}$	Input logic High Voltage		2			V
$V_{IT-(IN)}$	Input logic Low Voltage				0.8	V
I_{IH}	High-Level Input Leakage Current	$V_{IH} = V_{DDA}$ at INx or ENx			20	μA
I_{IL}	Low-Level Input Leakage Current	$V_{IL} = 0\text{ V}$ at INx	-20			μA
Z_O	Output Impedance ²			50		Ω
CMTI	Common-mode Transient Immunity	$V_I = V_{DDI}^1$ or 0 V, $V_{CM} = 1200\text{V}$; See 错误!未找到引用源。	100	150		$\text{kV}/\mu\text{s}$
C_i	Input Capacitance ³	$V_I = V_{DD}/2 + 0.4 \times \sin(2\pi ft)$, $f = 1\text{ MHz}$, $V_{DD} = 2.5\text{ V}$		2		pF

Notes:

- V_{DDI} = Input-side supply V_{DD} , V_{DDO} = Output-side supply V_{DD} .
- The nominal output impedance of each isolator driver is $50\ \Omega \pm 40\%$.
- Measured from pin to Ground.

7.9. Supply Current Characteristics
 $V_{DDA} = V_{DDB} = 5\text{ V} \pm 10\%$, $T_A = -40$ to 125°C (over recommended operating conditions, unless otherwise specified).

Parameters	Test conditions	SUPPLY CURRENT	MIN	TYP	MAX	UNIT
CA-IS3760						
Supply Current – DC Signal	$V_{IN} = 0\text{V}$ (CA-IS3760L); $V_{IN} = V_{DDA}$ (CA-IS3760H)	I_{DDA}		2.0	2.9	mA
		I_{DDB}		3.9	5.7	
	$V_{IN} = V_{DDA}$ (CA-IS3760L); $V_{IN} = 0\text{V}$ (CA-IS3760H)	I_{DDA}		7.0	10.7	
		I_{DDB}		4.1	6.1	
Supply Current – AC Signal	All Channels Switching with 50% Duty Cycle Square Wave Clock Input with 5V Amplitude; $C_L = 15\text{ pF}$ for Each Channel.	1Mbps (500kHz)	I_{DDA}	4.5	6.8	
			I_{DDB}	6.3	9.3	
		10Mbps (5MHz)	I_{DDA}	4.8	7.2	
			I_{DDB}	26.9	40.6	
		100Mbps (50MHz)	I_{DDA}	6.4	9.5	
			I_{DDB}	59.0	80	
CA-IS3761						
Supply Current – DC Signal	$V_{IN} = 0\text{V}$ (CA-IS3761L); $V_{IN} = V_{DDI}^1$ (CA-IS3761H)	I_{DDA}		2.3	3.4	mA
		I_{DDB}		3.6	5.3	
	$V_{IN} = V_{DDI}^1$ (CA-IS3761L); $V_{IN} = 0\text{V}$ (CA-IS3761H)	I_{DDA}		6.5	9.9	
		I_{DDB}		4.6	6.9	
Supply Current – AC Signal	All Channels Switching with 50% Duty Cycle Square Wave Clock Input with 5V Amplitude; $C_L = 15\text{ pF}$ for Each Channel.	1Mbps (500kHz)	I_{DDA}	4.5	6.7	
			I_{DDB}	5.7	8.4	
		10Mbps (5MHz)	I_{DDA}	5.1	7.6	
			I_{DDB}	19.8	29.9	
		100Mbps (50MHz)	I_{DDA}	10.6	16.3	
			I_{DDB}	45.6	62.1	
CA-IS3762						
Supply Current – DC Signal	$V_{IN} = 0\text{V}$ (CA-IS3762L); $V_{IN} = V_{DDI}^1$ (CA-IS3762H)	I_{DDA}		2.8	4.5	mA
		I_{DDB}		3.8	5.8	
	$V_{IN} = V_{DDI}^1$ (CA-IS3762L); $V_{IN} = 0\text{V}$ (CA-IS3762H)	I_{DDA}		6.2	9.9	
		I_{DDB}		5.6	8.7	
Supply Current – AC Signal	All Channels Switching with 50% Duty Cycle Square Wave Clock Input with 5V Amplitude; $C_L = 15\text{ pF}$ for Each Channel.	1Mbps (500kHz)	I_{DDA}	5.4	8.3	
			I_{DDB}	6.3	9.5	
		10Mbps (5MHz)	I_{DDA}	13.1	18.3	
			I_{DDB}	21.0	31.5	
		100Mbps (50MHz)	I_{DDA}	26.0	36.9	
			I_{DDB}	44.7	72.2	
CA-IS3763						
Supply Current – DC Signal	$V_{IN} = 0\text{V}$ (CA-IS3763L); $V_{IN} = V_{DDI}^1$ (CA-IS3763H)	I_{DDA}		2.9	4.4	mA
		I_{DDB}		2.9	4.4	
	$V_{IN} = V_{DDI}^1$ (CA-IS3763L); $V_{IN} = 0\text{V}$ (CA-IS3763H)	I_{DDA}		5.5	8.4	
		I_{DDB}		5.5	8.4	
Supply Current – AC Signal	All Channels Switching with 50% Duty Cycle Square Wave Clock Input with 5V Amplitude; $C_L = 15\text{ pF}$ for Each Channel.	1Mbps (500kHz)	I_{DDA}	4.3	6.5	
			I_{DDB}	4.3	6.5	
		10Mbps (5MHz)	I_{DDA}	5.7	8.4	
			I_{DDB}	5.7	8.4	
		100Mbps (50MHz)	I_{DDA}	19.9	30.0	
			I_{DDB}	19.9	30.0	
Note:						

1. V_{DDI} = Input-side supply V_{DD} .

 $V_{DDA} = V_{DDB} = 3.3\text{ V} \pm 10\%$, $T_A = -40$ to 125°C (over recommended operating conditions, unless otherwise specified)

Parameters	Test conditions	SUPPLY CURRENT	MIN	TYP	MAX	UNIT
CA-IS3760						
Supply Current – DC Signal	$V_{IN} = 0\text{V}$ (CA-IS3760L); $V_{IN} = V_{DDA}$ (CA-IS3760H)	I_{DDA}		1.9	2.8	mA
		I_{DDB}		3.6	5.4	
	$V_{IN} = V_{DDA}$ (CA-IS3760L); $V_{IN} = 0\text{V}$ (CA-IS3760H)	I_{DDA}		6.8	10.5	
		I_{DDB}		3.9	5.7	
Supply Current – AC Signal	All Channels Switching with 50% Duty Cycle Square Wave Clock Input with 3.3V Amplitude; $C_L = 15\text{ pF}$ for Each Channel.	1Mbps (500kHz)	I_{DDA}	4.4	6.7	
			I_{DDB}	5.2	7.5	
		10Mbps (5MHz)	I_{DDA}	4.6	7.0	
			I_{DDB}	18.3	24.6	
		100Mbps (50MHz)	I_{DDA}	6.1	9.0	
			I_{DDB}	38.3	51.8	
CA-IS3761						
Supply Current – DC Signal	$V_{IN} = 0\text{V}$ (CA-IS3761L); $V_{IN} = V_{DDI}^1$ (CA-IS3761H)	I_{DDA}		2.2	3.2	mA
		I_{DDB}		3.4	5.0	
	$V_{IN} = V_{DDI}^1$ (CA-IS3761L); $V_{IN} = 0\text{V}$ (CA-IS3761H)	I_{DDA}		6.3	9.7	
		I_{DDB}		4.4	6.5	
Supply Current – AC Signal	All Channels Switching with 50% Duty Cycle Square Wave Clock Input with 3.3V Amplitude; $C_L = 15\text{ pF}$ for Each Channel.	1Mbps (500kHz)	I_{DDA}	4.3	6.5	
			I_{DDB}	4.8	7.1	
		10Mbps (5MHz)	I_{DDA}	4.8	7.1	
			I_{DDB}	13.9	18.9	
		100Mbps (50MHz)	I_{DDA}	8.6	12.2	
			I_{DDB}	30.1	40.8	
CA-IS3762						
Supply Current – DC Signal	$V_{IN} = 0\text{V}$ (CA-IS3762L); $V_{IN} = V_{DDI}^1$ (CA-IS3762H)	I_{DDA}		2.7	4.3	mA
		I_{DDB}		3.6	5.6	
	$V_{IN} = V_{DDI}^1$ (CA-IS3762L); $V_{IN} = 0\text{V}$ (CA-IS3762H)	I_{DDA}		6.0	9.7	
		I_{DDB}		5.4	8.4	
Supply Current – AC Signal	All Channels Switching with 50% Duty Cycle Square Wave Clock Input with 3.3V Amplitude; $C_L = 15\text{ pF}$ for Each Channel.	1Mbps (500kHz)	I_{DDA}	4.9	7.7	
			I_{DDB}	5.6	8.5	
		10Mbps (5MHz)	I_{DDA}	10.0	14.3	
			I_{DDB}	15.2	22.7	
		100Mbps (50MHz)	I_{DDA}	18.5	26.2	
			I_{DDB}	30.4	48.1	
CA-IS3763						
Supply Current – DC Signal	$V_{IN} = 0\text{V}$ (CA-IS3763L); $V_{IN} = V_{DDI}^1$ (CA-IS3763H)	I_{DDA}		2.7	4.1	mA
		I_{DDB}		2.7	4.1	
	$V_{IN} = V_{DDI}^1$ (CA-IS3763L); $V_{IN} = 0\text{V}$ (CA-IS3763H)	I_{DDA}		5.3	8.1	
		I_{DDB}		5.3	8.1	
Supply Current – AC Signal	All Channels Switching with 50% Duty Cycle Square Wave Clock Input with 3.3V Amplitude; $C_L = 15\text{ pF}$ for Each Channel.	1Mbps (500kHz)	I_{DDA}	4.1	6.2	
			I_{DDB}	4.1	6.2	
		10Mbps (5MHz)	I_{DDA}	5.1	7.4	
			I_{DDB}	5.1	7.4	
		100Mbps (50MHz)	I_{DDA}	13.6	18.7	
			I_{DDB}	13.6	18.7	
Note:						
1. V_{DDI} = Input-side supply V_{DD} .						

$V_{DDA} = V_{DDB} = 2.5\text{ V} \pm 10\%$, $T_A = -40$ to 125°C (over recommended operating conditions, unless otherwise specified)

Parameters	Test conditions	SUPPLY CURRENT	MIN	TYP	MAX	UNIT	
CA-IS3760							
Supply Current – DC Signal	$V_{IN} = 0\text{V}$ (CA-IS3760L); $V_{IN} = V_{DDA}$ (CA-IS3760H)	I_{DDA}		1.9	2.7	mA	
		I_{DDB}		3.6	5.2		
	$V_{IN} = V_{DDA}$ (CA-IS3760L); $V_{IN} = 0\text{V}$ (CA-IS3760H)	I_{DDA}		6.8	10.4		
		I_{DDB}		3.8	5.5		
Supply Current – AC Signal	All Channels Switching with 50% Duty Cycle Square Wave Clock Input with 2.5V Amplitude; $C_L = 15\text{ pF}$ for Each Channel.	1Mbps (500kHz)	I_{DDA}		4.3		6.6
			I_{DDB}		4.8		6.9
		10Mbps (5MHz)	I_{DDA}		4.6		6.9
			I_{DDB}		14.7		19.8
		100Mbps (50MHz)	I_{DDA}		5.7	8.5	
			I_{DDB}		28.9	39.0	
CA-IS3761							
Supply Current – DC Signal	$V_{IN} = 0\text{V}$ (CA-IS3761L); $V_{IN} = V_{DDI}^1$ (CA-IS3761H)	I_{DDA}		2.1	3.2	mA	
		I_{DDB}		3.3	4.8		
	$V_{IN} = V_{DDI}^1$ (CA-IS3761L); $V_{IN} = 0\text{V}$ (CA-IS3761H)	I_{DDA}		6.3	9.6		
		I_{DDB}		4.3	6.4		
Supply Current – AC Signal	All Channels Switching with 50% Duty Cycle Square Wave Clock Input with 2.5V Amplitude; $C_L = 15\text{ pF}$ for Each Channel.	1Mbps (500kHz)	I_{DDA}		4.3		6.4
			I_{DDB}		4.5		6.6
		10Mbps (5MHz)	I_{DDA}		4.6		6.9
			I_{DDB}		11.4		15.5
		100Mbps (50MHz)	I_{DDA}		7.6	10.8	
			I_{DDB}		23.1	31.2	
CA-IS3762							
Supply Current – DC Signal	$V_{IN} = 0\text{V}$ (CA-IS3762L); $V_{IN} = V_{DDI}^1$ (CA-IS3762H)	I_{DDA}		2.6	4.2	mA	
		I_{DDB}		3.5	5.5		
	$V_{IN} = V_{DDI}^1$ (CA-IS3762L); $V_{IN} = 0\text{V}$ (CA-IS3762H)	I_{DDA}		6.0	9.6		
		I_{DDB}		5.3	8.3		
Supply Current – AC Signal	All Channels Switching with 50% Duty Cycle Square Wave Clock Input with 2.5V Amplitude; $C_L = 15\text{ pF}$ for Each Channel.	1Mbps (500kHz)	I_{DDA}		4.8		7.4
			I_{DDB}		5.2		8.0
		10Mbps (5MHz)	I_{DDA}		8.6		12.4
			I_{DDB}		12.6		18.6
		100Mbps (50MHz)	I_{DDA}		14.8	21.2	
			I_{DDB}		23.3	36.3	
CA-IS3763							
Supply Current – DC Signal	$V_{IN} = 0\text{V}$ (CA-IS3763L); $V_{IN} = V_{DDI}^1$ (CA-IS3763H)	I_{DDA}		2.7	4.0	mA	
		I_{DDB}		2.7	4.0		
	$V_{IN} = V_{DDI}^1$ (CA-IS3763L); $V_{IN} = 0\text{V}$ (CA-IS3763H)	I_{DDA}		5.2	8.0		
		I_{DDB}		5.2	8.0		
Supply Current – AC Signal	All Channels Switching with 50% Duty Cycle Square Wave Clock Input with 2.5V Amplitude; $C_L = 15\text{ pF}$ for Each Channel.	1Mbps (500kHz)	I_{DDA}		4.0		6.1
			I_{DDB}		4.0		6.1
		10Mbps (5MHz)	I_{DDA}		4.8		7.0
			I_{DDB}		4.8		7.0
		100Mbps (50MHz)	I_{DDA}		11.3	16.0	
			I_{DDB}		11.3	16.0	
Note:							
1. V_{DDI} = Input-side supply V_{DD} .							

7.10. Timing Characteristics
 $V_{DDA} = V_{DDB} = 5\text{ V} \pm 10\%$, $T_A = -40\text{ to }125^\circ\text{C}$ (over recommended operating conditions, unless otherwise specified)

PARAMETER		TEST CONDITIONS	MIN	TYP	MAX	UNIT
DR	Data Rate		0		150	Mbps
PW_{min}	Minimum Pulse Width				5.0	ns
t_{PLH}, t_{PHL}	Propagation Delay Time	See Figure 8- 1	5.0	12.0	15.0	ns
PWD	Pulse Width Distortion $ t_{PLH} - t_{PHL} $					
$t_{sk(o)}$	Channel-to-Channel Output Skew Time ¹	Same-direction channels		0.4	2.5	ns
$t_{sk(pp)}$	Part-to-Part Output Skew Time ²			2.0	4.5	ns
t_r	Output Signal Rise Time	See Figure 8- 1		2.5	4.0	ns
t_f	Output Signal Fall Time	See Figure 8- 1		2.5	4.0	ns
t_{DO}	Default Output Delay Time from Input Power Loss	See Figure 8- 1		8	12	μs
t_{SU}	Start-up Time			15	40	μs

Notes:

- tsk(o) is the skew between outputs of a single device with all driving inputs connected together and the outputs switching in the same direction while driving identical loads.
- tsk(pp) is the magnitude of the difference in propagation delay times between any terminals of different devices switching in the same direction while operating at identical supply voltages, temperature, input signals and loads.

 $V_{DDA} = V_{DDB} = 3.3\text{ V} \pm 10\%$, $T_A = -40\text{ to }125^\circ\text{C}$ (over recommended operating conditions, unless otherwise specified)

PARAMETER		TEST CONDITIONS	MIN	TYP	MAX	UNIT
DR	Data Rate		0		150	Mbps
PW_{min}	Minimum Pulse Width				5.0	ns
t_{PLH}, t_{PHL}	Propagation Delay Time	See Figure 8- 1	5.0	12.0	15.0	ns
PWD	Pulse Width Distortion $ t_{PLH} - t_{PHL} $					
$t_{sk(o)}$	Channel-to-Channel Output Skew Time ¹	Same-direction channels		0.4	2.5	ns
$t_{sk(pp)}$	Part-to-Part Output Skew Time ²			2.0	4.5	ns
t_r	Output Signal Rise Time	See Figure 8- 1		2.5	4.0	ns
t_f	Output Signal Fall Time	See Figure 8- 1		2.5	4.0	ns
t_{DO}	Default Output Delay Time from Input Power Loss	See Figure 8- 1		8	12	μs
t_{SU}	Start-up Time			15	40	μs

Notes:

- tsk(o) is the skew between outputs of a single device with all driving inputs connected together and the outputs switching in the same direction while driving identical loads.
- tsk(pp) is the magnitude of the difference in propagation delay times between any terminals of different devices switching in the same direction while operating at identical supply voltages, temperature, input signals and loads.

 $V_{DDA} = V_{DDB} = 2.5\text{ V} \pm 10\%$, $T_A = -40\text{ to }125^\circ\text{C}$ (over recommended operating conditions, unless otherwise specified)

PARAMETER		TEST CONDITIONS	MIN	TYP	MAX	UNIT
DR	Data Rate		0		150	Mbps
PW_{min}	Minimum Pulse Width				5.0	ns
t_{PLH}, t_{PHL}	Propagation Delay Time	See Figure 8- 1	5.0	12.0	15.0	ns
PWD	Pulse Width Distortion $ t_{PLH} - t_{PHL} $					
$t_{sk(o)}$	Channel-to-Channel Output Skew Time ¹	Same-direction channels		0.4	2.5	ns
$t_{sk(pp)}$	Part-to-Part Output Skew Time ²			1.0	5.0	ns
t_r	Output Signal Rise Time	See 错误!未找到引用源。		2.5	4.0	ns
t_f	Output Signal Fall Time	See Figure 8- 1		2.5	4.0	ns
t_{DO}	Default Output Delay Time from Input Power Loss	See Figure 8- 1		8	12	μs
t_{SU}	Start-up Time			15	40	μs

Notes:

1. $t_{sk(o)}$ is the skew between outputs of a single device with all driving inputs connected together and the outputs switching in the same direction while driving identical loads.
2. $t_{sk(pp)}$ is the magnitude of the difference in propagation delay times between any terminals of different devices switching in the same direction while operating at identical supply voltages, temperature, input signals and loads.

8. Parameter Measurement Information

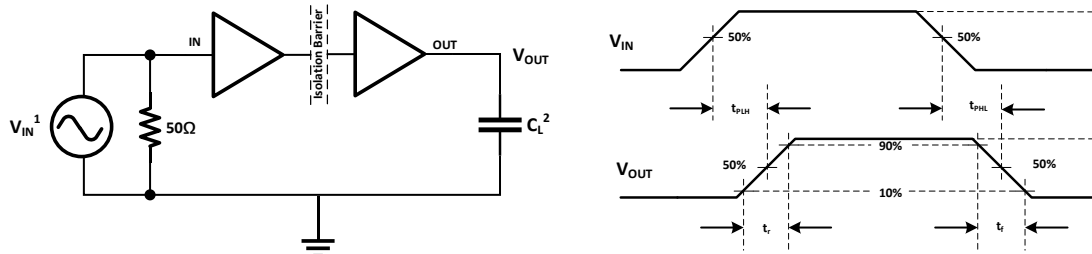

Notes:

1. A square wave generator provide V_{IN} input signal with the following characteristics: frequency $\leq 100\text{kHz}$, 50% duty cycle, $t_r \leq 3\text{ns}$, $t_f \leq 3\text{ns}$, $Z_{out} = 50\Omega$. At the input, 50Ω resistor is required to terminate input generator signal. It is not needed in actual application.
2. $C_L = 15\text{pF}$ and includes external circuit (instrumentation and fixture etc.) capacitance. Since the load capacitance influence the output rising time, it's a key factor in the timing characteristic measurement.

Figure 8- 1 Switching Characteristics Test Circuit and Voltage Waveforms

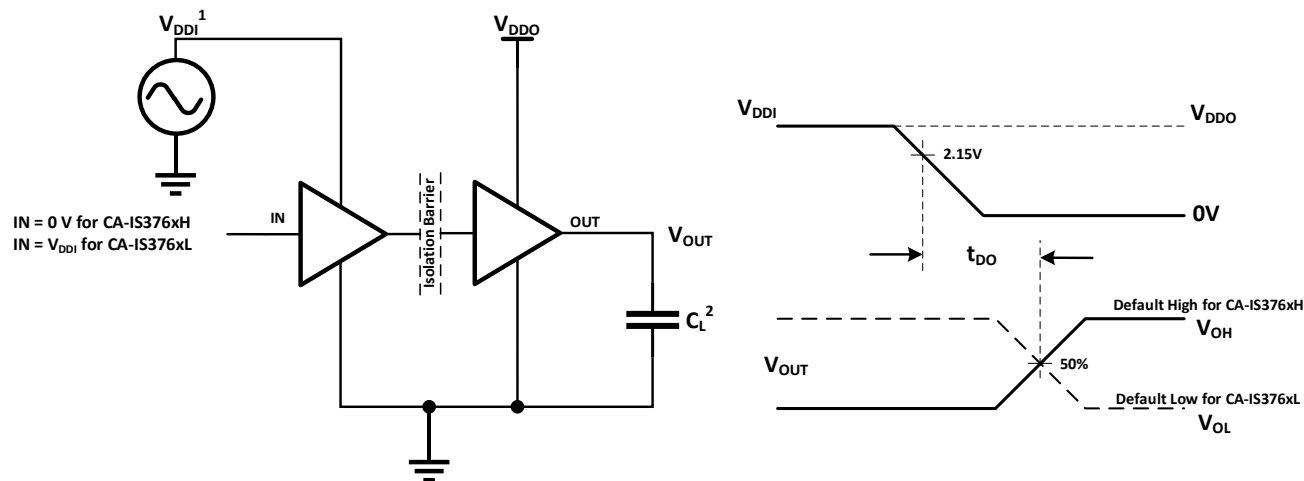

Notes:

1. Power Supply Ramp Rate = 10 mV/ns. V_{DDI} should ramp over 2.375V, and less than 5.5V.
2. $C_L = 15\text{pF}$ and includes external circuit (instrumentation and fixture etc.) capacitance. Since the load capacitance influence the output rising time, it's a key factor in the timing characteristic measurement.

Figure 8- 2 Default Output Delay Time Test Circuit and Voltage Waveforms

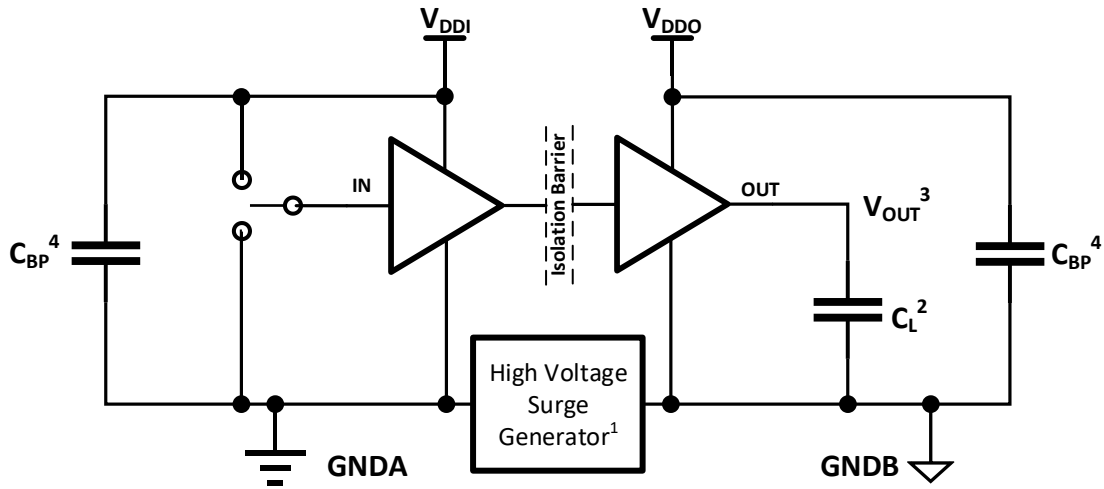
Notes:

1. The High Voltage Surge Generator generates repetitive high voltage surges with > 1kV amplitude, rise time <10ns and fall time <10ns, to reach common-mode transient noise with > 150kV/ μ s slew rate.
2. $C_L = 15\text{pF}$ and includes external circuit (instrumentation and fixture etc.) capacitance.
3. Pass-fail criteria: the output must remain stable.
4. C_{BP} (0.1 ~ 1 μ F) is bypass capacitance.

Figure 8- 3 Common-Mode Transient Immunity Test Circuit

9. Detailed Description

9.1. Overview

The CA-IS376x are a family of six-channel digital galvanic isolators using Chipanalog’s full differential capacitive isolation technology. These devices have an ON-OFF keying (OOK) modulation scheme to transfer digital signals across the SiO₂ based isolation barrier between circuits with different power domains. The transmitter sends a high frequency carrier across the barrier to represent one digital state and sends no signal to represent the other digital state. The receiver demodulates the signal and recovery input signal at output through a buffer stage. With this OOK architecture, CA-IS376x family of devices build a robust data transmission path between different power domains without any special start-up initialization requirements. These devices also incorporate advanced full differential techniques to maximize the CMTI performance and minimize the radiated emissions due the high frequency carrier and IO buffer switching.

9.2. Functional Block Diagram

The conceptual block diagram of a digital capacitive isolator, [错误!未找到引用源。](#), shows a functional block diagram of a typical channel; [错误!未找到引用源。](#) shows the operating waveform of a typical channel. Each channel of the CA-IS376x is unidirectional, only passes data in one direction as indicated in the functional diagram. Each device of this family features six unidirectional channels that operate independently with guaranteed data rates from DC up to 150Mbps.

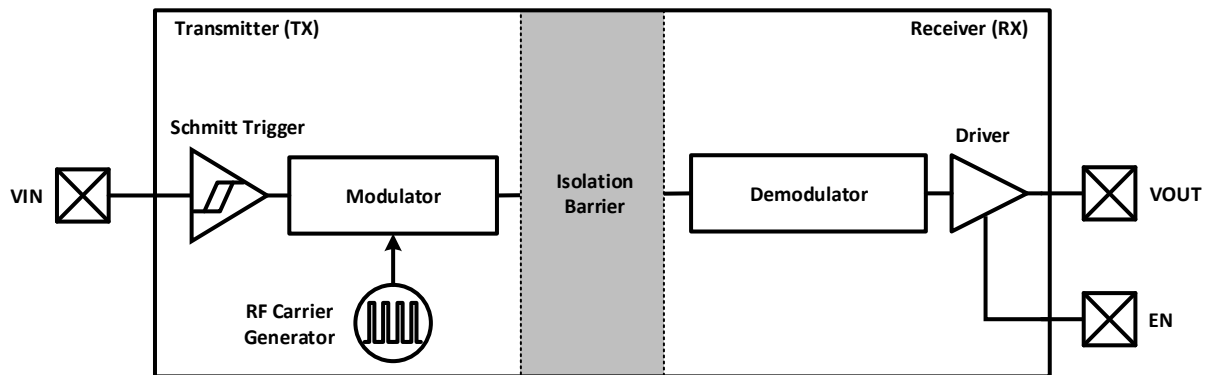

Figure 9- 1 Functional Block Diagram of a Single Channel

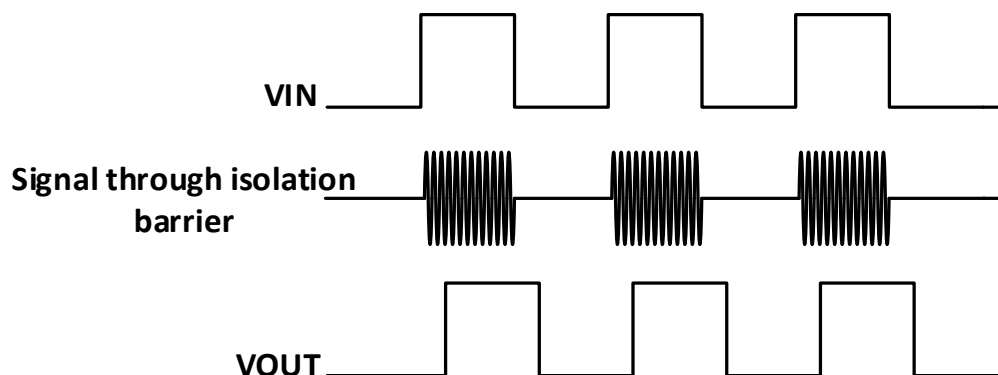

Figure 9- 2 Conceptual Operation Waveforms of a Single Channel

9.3. Device Operation Modes

Table 9-1 lists the operation modes for the CA-IS376x devices.

Table 9-1. Operation Mode

V_{DDI}^1	V_{DDO}^1	INPUT (VIx) ²	OUTPUT (VOx)	OPERATION
PU	PU	H	H	Normal operation mode: A channel output follows the logic state of its input.
		L	L	
		Open	Default	Default output mode: When input VIx is open, the corresponding channel output goes to its default logic state. Default is <i>High</i> for CA-IS376xH and <i>Low</i> for CA-IS376xL.
PD	PU	X	Default	Default output mode: When V_{DDI} is unpowered, a channel output assumes the logic state based on its default option. Default is <i>High</i> for CA-IS376xH and <i>Low</i> for CA-IS376xL.
X	PD	X	Undetermined	If the output side V_{DDO} is unpowered, a channel output is undetermined. ⁴

Notes:

- V_{DDI} = Input-side supply V_{DD} ; V_{DDO} = Output-side supply V_{DD} ; PU = Powered up ($V_{DD} \geq V_{DD(UVLO+)}$); PD = Powered down ($V_{DD} \leq V_{DD(UVLO-)}$); X = Irrelevant; H = High level; L = Low level; Z = High Impedance.
- A strongly driven input signal can weakly power the floating V_{DD} through an internal protection diode and cause undetermined output.
- It is recommended to connect the enable inputs to external logic high or low level when the CA-IS376x operates in noisy environments.
- The outputs are in undetermined state when $V_{DD(UVLO-)} < V_{DDI}$, $V_{DDO} < V_{DD(UVLO+)}$.

10. Application and Implementation

The CA-IS376x isolation ICs provide complete galvanic isolation between two power domains, protecting circuits from high common-mode transients and faults, eliminating ground loops. In many applications, digital isolators are replacing optocouplers because they can reduce the power requirements and take up less board space while offering the same isolation capability. The CA-IS376x devices are the high-performance, six-channel digital isolators. Unlike optocouplers, which require external components to improve performance, provide bias, or limit current, the CA-IS376x devices only require two external bypass capacitors to operate. To reduce ripple and the chance of introducing data errors, bypass VDDA and VDDB pins with 0.1 μ F to 1 μ F low-ESR ceramic capacitors to GNDA and GNDB respectively. Place the bypass capacitors as close to the power supply input pins as possible. **错误!未找到引用源。** shows typical operating circuit of the CA-IS3763; **错误!未找到引用源。** is the typical applications for CA-IS37xx series products.

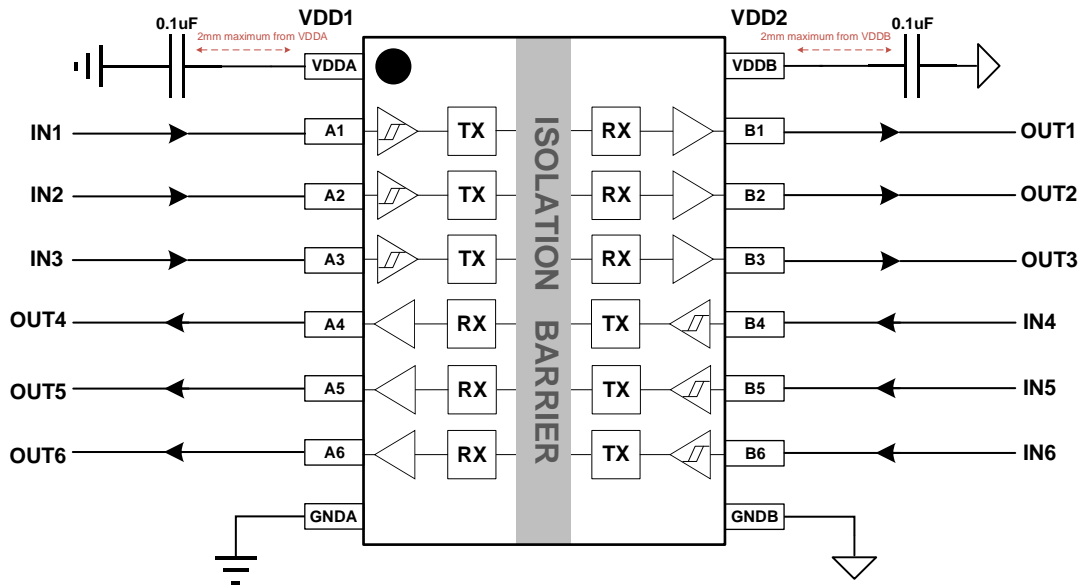

Figure 10- 1 Typical Application Circuit of CA-IS3763

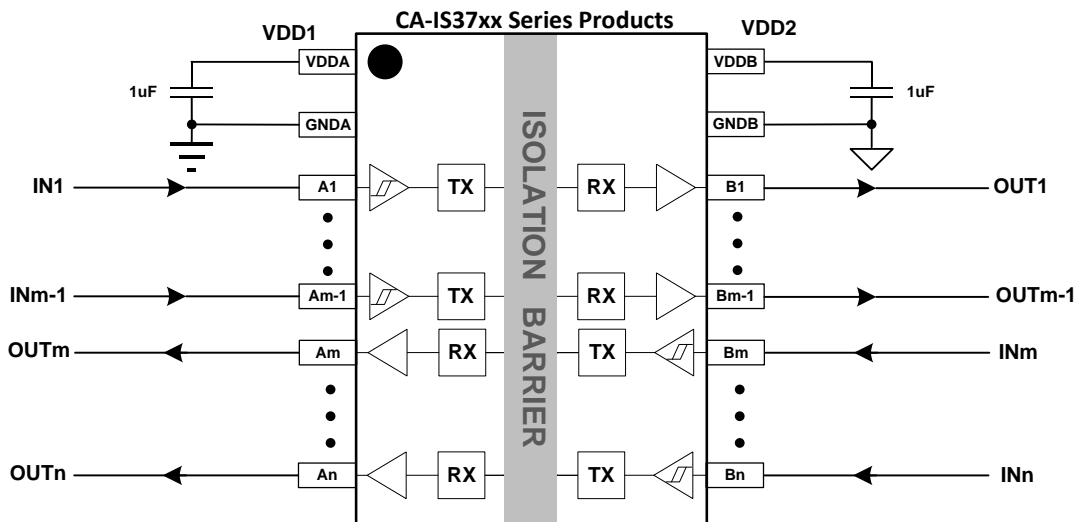
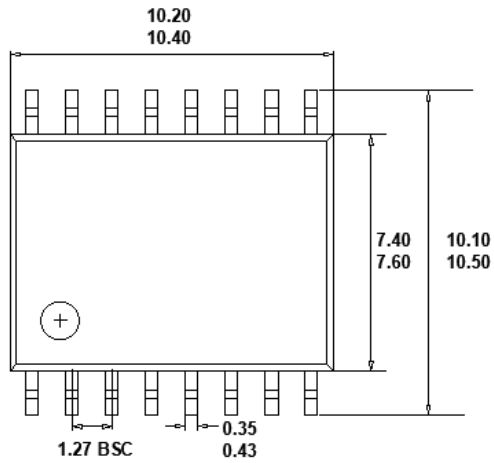

Figure 10- 2 Typical Applications for the CA-IS37xx Series Digital Isolators

11. Package Information

11.1. 16-Pin Wide Body SOIC Package Outline



TOP VIEW

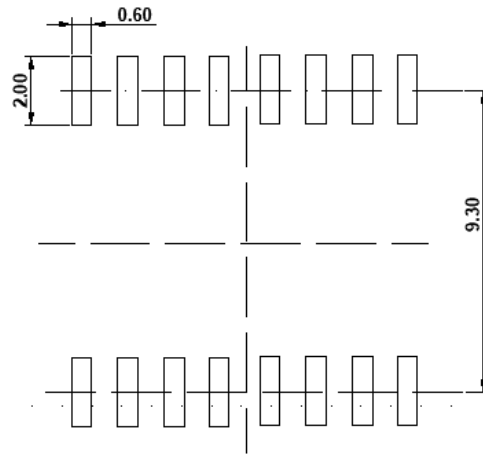

RECOMMENDED LAND PATTERN

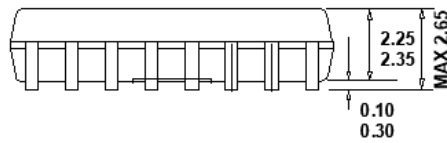

FRONT VIEW

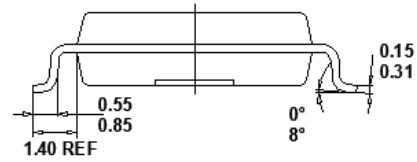

LEFT SIDE VIEW

Note:

1. All dimensions are in millimeters, angles are in degrees.

11.2. 16-Pin Narrow Body SOIC Package Outline

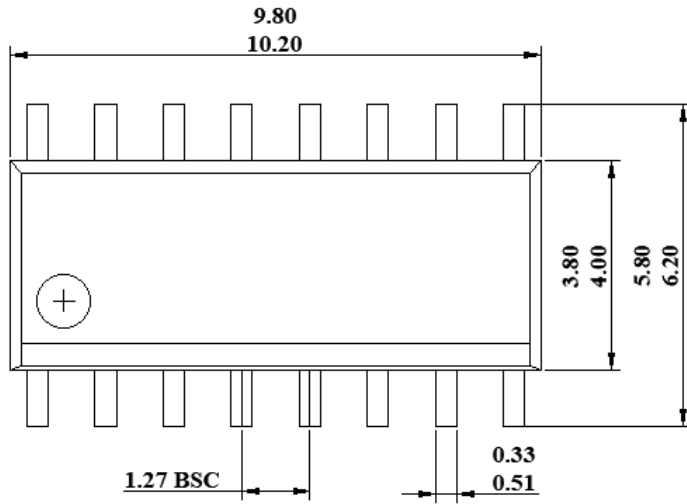

TOP VIEW

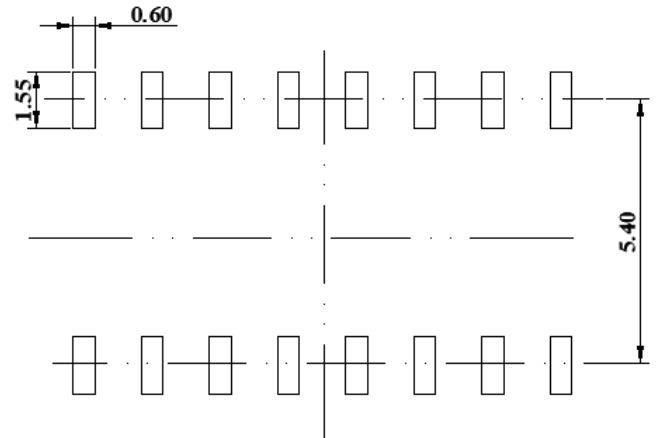

RECOMMENDED LAND PATTERN

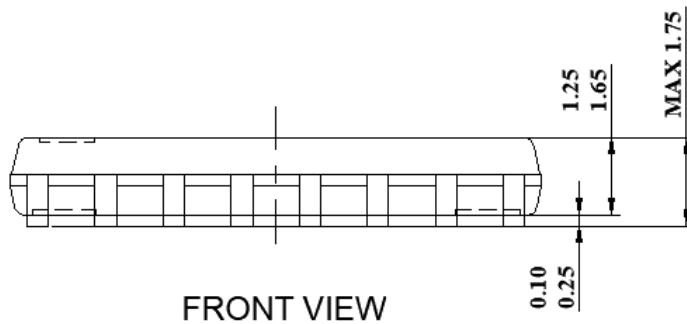

FRONT VIEW

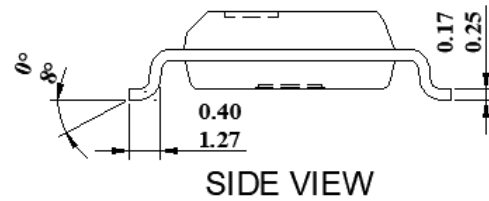

SIDE VIEW

Note:

1. All dimensions are in millimeters, angles are in degrees.

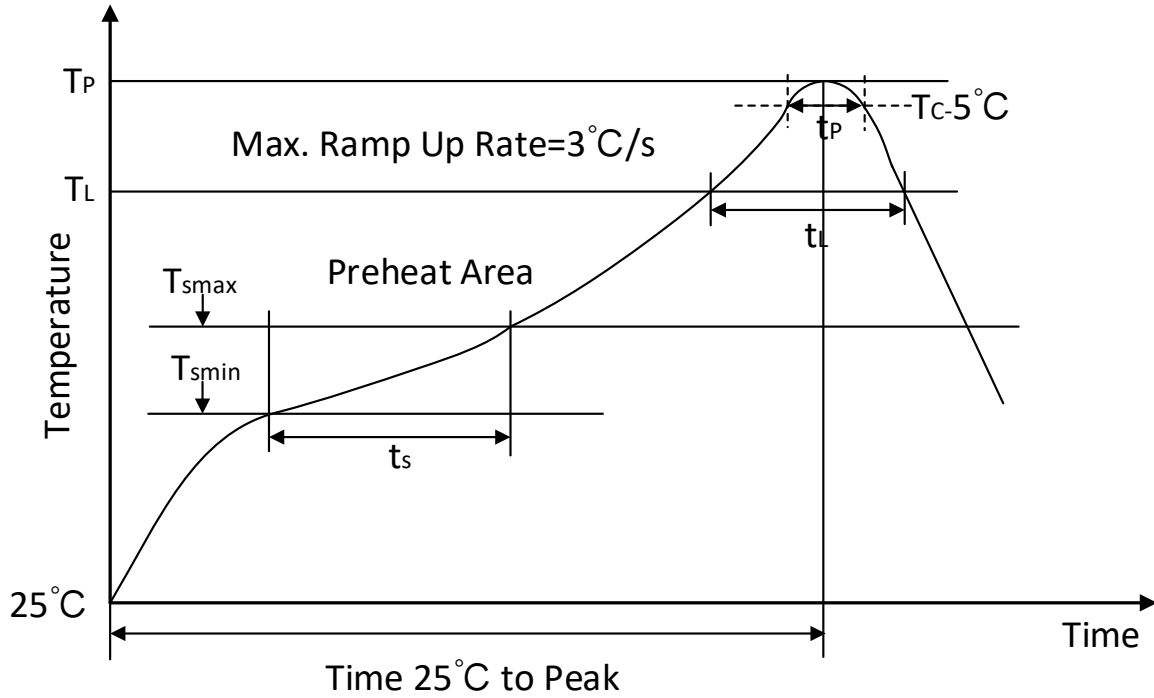
12. Soldering Temperature (reflow) Profile

Figure 12- 1 Soldering Temperature (reflow) Profile
Table 12- 1 Soldering Temperature Parameter

Profile Feature	Pb-Free Assembly
Average ramp-up rate(217 °C to Peak)	3°C /second max
Time of Preheat temp(from 150 °C to 200 °C)	60-120 second
Peak temperature	260 +5/-0 °C
Time to be maintained above 217 °C	60-150 second
Time within 5 °C of actual peak temp	30 second
Ramp-down rate	6 °C/second max.
Time from 25°C to peak temp	8 minutes max

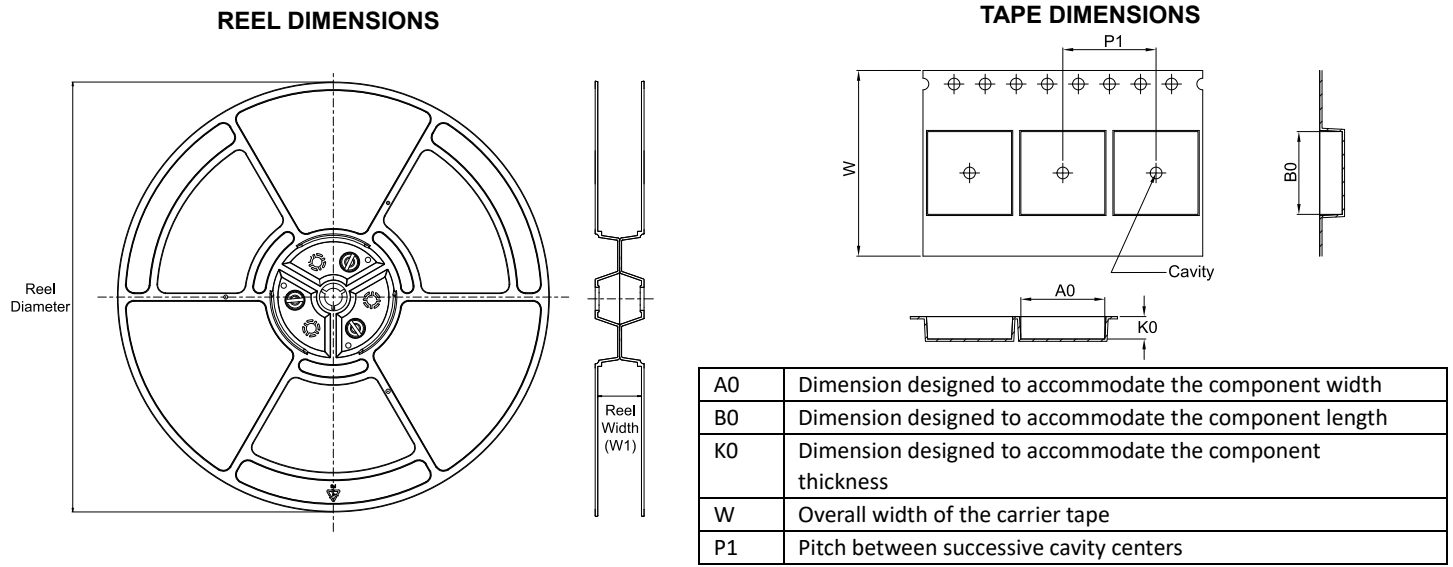
13. Tape and Reel Information

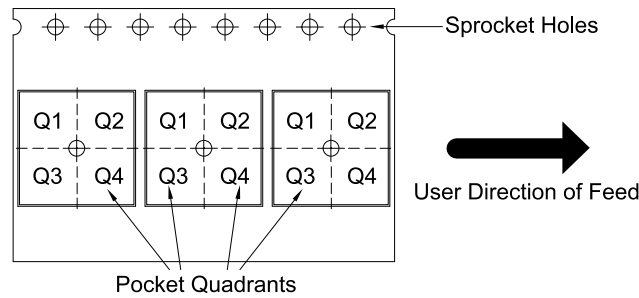

QUADRANT ASSIGNMENTS FOR PIN 1 ORIENTATION IN TAPE



*All dimensions are nominal

Device	Package Type	Package Drawing	Pins	SPQ	Reel Diameter (mm)	Reel Width W1 (mm)	A0 (mm)	B0 (mm)	K0 (mm)	P1 (mm)	W (mm)	Pin1 Quadrant
CA-IS3760LN	SOIC	N	16	2500	330	16.4	6.40	10.30	2.10	8.00	16.00	Q1
CA-IS3760LW	SOIC	W	16	1000	330	16.4	10.90	10.70	3.20	12.00	16.00	Q1
CA-IS3760HN	SOIC	N	16	2500	330	16.4	6.40	10.30	2.10	8.00	16.00	Q1
CA-IS3760HW	SOIC	W	16	1000	330	16.4	10.90	10.70	3.20	12.00	16.00	Q1
CA-IS3761LN	SOIC	N	16	2500	330	16.4	6.40	10.30	2.10	8.00	16.00	Q1
CA-IS3761LW	SOIC	W	16	1000	330	16.4	10.90	10.70	3.20	12.00	16.00	Q1
CA-IS3761HN	SOIC	N	16	2500	330	16.4	6.40	10.30	2.10	8.00	16.00	Q1
CA-IS3761HW	SOIC	W	16	1000	330	16.4	10.90	10.70	3.20	12.00	16.00	Q1
CA-IS3762LN	SOIC	N	16	2500	330	16.4	6.40	10.30	2.10	8.00	16.00	Q1
CA-IS3762LW	SOIC	W	16	1000	330	16.4	10.90	10.70	3.20	12.00	16.00	Q1
CA-IS3762HN	SOIC	N	16	2500	330	16.4	6.40	10.30	2.10	8.00	16.00	Q1
CA-IS3762HW	SOIC	W	16	1000	330	16.4	10.90	10.70	3.20	12.00	16.00	Q1
CA-IS3763LN	SOIC	N	16	2500	330	16.4	6.40	10.30	2.10	8.00	16.00	Q1
CA-IS3763LW	SOIC	W	16	1000	330	16.4	10.90	10.70	3.20	12.00	16.00	Q1
CA-IS3763HN	SOIC	N	16	2500	330	16.4	6.40	10.30	2.10	8.00	16.00	Q1
CA-IS3763HW	SOIC	W	16	1000	330	16.4	10.90	10.70	3.20	12.00	16.00	Q1

14. Important statement

The above information is for reference only and used for helping Chipanalog customers with design, research and development. Chipanalog reserves the rights to change the above information due to technological innovation without advance notice.

All Chipanalog products pass ex-factory test. As for specific practical applications, customers need to be responsible for evaluating and determining whether the products are applicable or not by themselves. Chipanalog's authorization for customers to use the resources are only limited to development of the related applications of the Chipanalog products. In addition to this, the resources cannot be copied or shown, and Chipanalog is not responsible for any claims, compensations, costs, losses, liabilities and the like arising from the use of the resources.

Trademark information

Chipanalog Inc.® and Chipanalog® are registered trademarks of Chipanalog.



<http://www.chipanalog.com>