

PROTECTION PRODUCTS

Description

The LC03-6 transient voltage suppressor is designed to protect components which are connected to high speed telecommunication lines from voltage surges caused by **lightning**, electrostatic discharge (**ESD**), cable discharge events (**CDE**), and electrical fast transients (**EFT**).

TVS diodes are ideal for use as board level protection of sensitive semiconductor components. The LC03-6 combines a TVS diode with a rectifier bridge to provide transient protection in both common and differential mode with a single device. The capacitance of the device is minimized (< 25pF) to ensure correct signal transmission on high speed lines. The LC03-6 meets the short-haul (intra-building) transient immunity requirements of Bellcore 1089 for telecommunications applications.

The SO-8 surface mount package allows flexibility in the design of crowded PC boards.

Features

- ◆ 2000 watts peak pulse power ($t_p = 8/20\mu s$)
- ◆ Transient protection for high-speed data lines to **Bellcore 1089 (Intra-Building) 100A (2/10 μs)**
ITU K.20 $I_{pp}=40A$ (5/310 μs)
IEC 61000-4-2 (ESD) $\pm 15kV$ (air), $\pm 8kV$ (contact)
IEC 61000-4-4 (EFT) 40A (5/50ns)
IEC 61000-4-5 (Lightning) 100A (8/20 μs)
- ◆ Protects two lines in common and differential mode
- ◆ Low capacitance for high-speed interfaces
- ◆ Low clamping and operating voltage
- ◆ Integrated structure saves board space and increases reliability
- ◆ Solid-state silicon avalanche technology

Mechanical Characteristics

- ◆ JEDEC SO-8 package
- ◆ RoHS/WEEE Compliant
- ◆ UL 497B listed
- ◆ Molding compound flammability rating: UL 94V-0
- ◆ Marking : Part number, date code
- ◆ Packaging : Tube or Tape and Reel per EIA 481

Applications

- ◆ T1/E1 Line Cards
- ◆ T3/E3 and DS3 Interfaces
- ◆ STS-1 Interfaces
- ◆ ISDN S/T-Interfaces
- ◆ ISDN U-Interfaces
- ◆ 10/100 Ethernet

Circuit Diagram

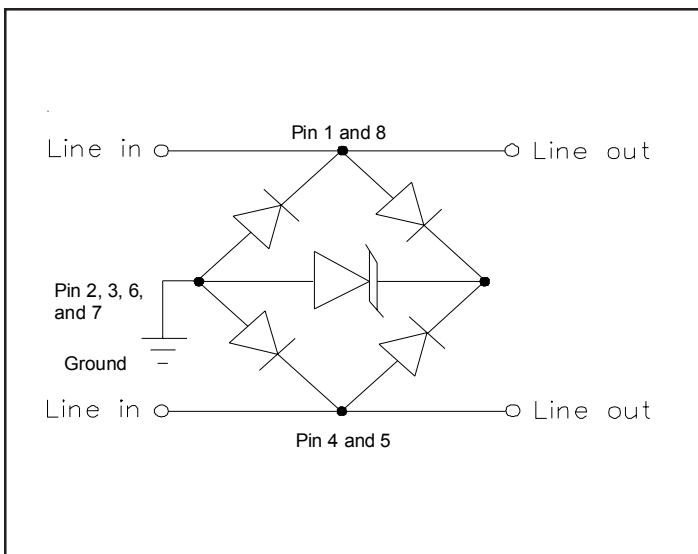

Schematic & PIN Configuration

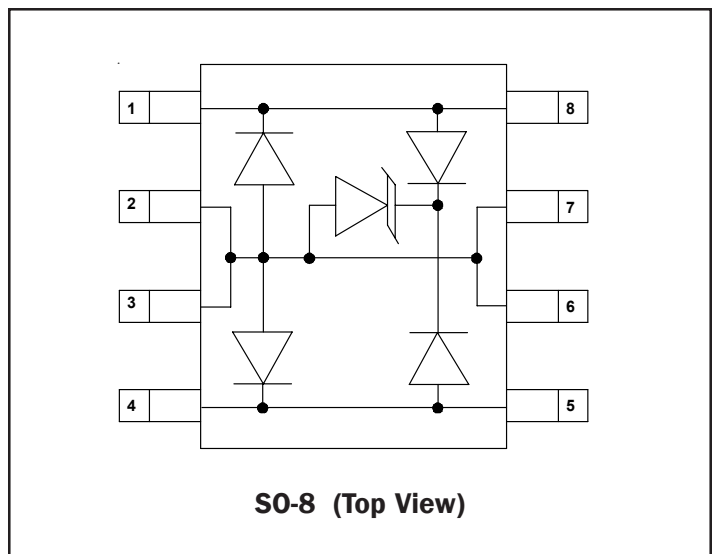

PROTECTION PRODUCTS
Absolute Maximum Rating

Rating	Symbol	Value	Units
Peak Pulse Power ($t_p = 8/20\mu s$)	P_{pk}	2000	Watts
Peak Pulse Current ($t_p = 8/20\mu s$)	I_{pp}	100	A
Lead Soldering Temperature	T_L	260 (10 sec.)	$^{\circ}C$
Operating Temperature	T_J	-55 to +125	$^{\circ}C$
Storage Temperature	T_{STG}	-55 to +150	$^{\circ}C$

Electrical Characteristics

LC03-6						
Parameter	Symbol	Conditions	Minimum	Typical	Maximum	Units
Reverse Stand-Off Voltage	V_{RWM}				6	V
Reverse Breakdown Voltage	V_{BR}	$I_t = 1mA$	6.8			V
Reverse Leakage Current	I_R	$V_{RWM} = 6V, T=25^{\circ}C$			25	μA
Clamping Voltage	V_C	$I_{pp} = 50A, t_p = 8/20\mu s$ Line-to-Ground			15	V
Clamping Voltage	V_C	$I_{pp} = 100A, t_p = 8/20\mu s$ Line-to-Ground			20	V
Junction Capacitance	C_J	Between I/O pins and Ground $V_R = 0V, f = 1MHz$		16	25	pF
		Between I/O pins $V_R = 0V, f = 1MHz$		8	12	pF

PROTECTION PRODUCTS

Typical Characteristics

Non-Repetitive Peak Pulse Power vs. Pulse Time

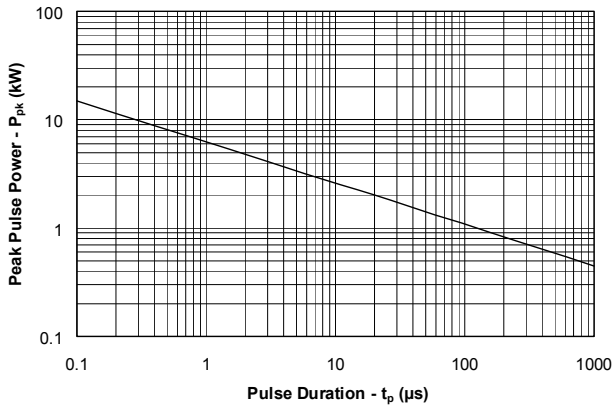

Power Derating Curve

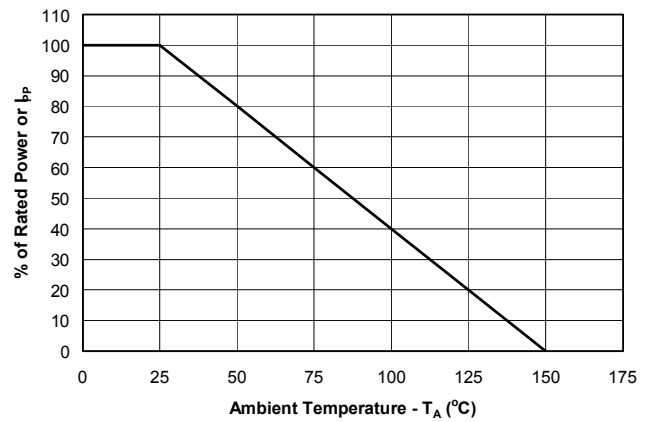

Pulse Waveform

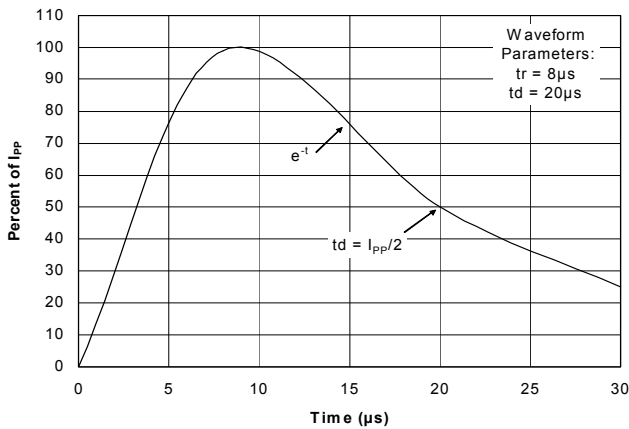

Clamping Voltage vs. Peak Pulse Current

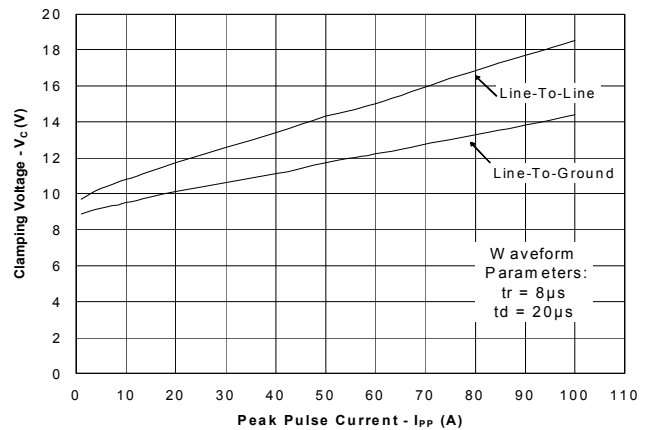

Normalized Capacitance vs. Reverse Voltage

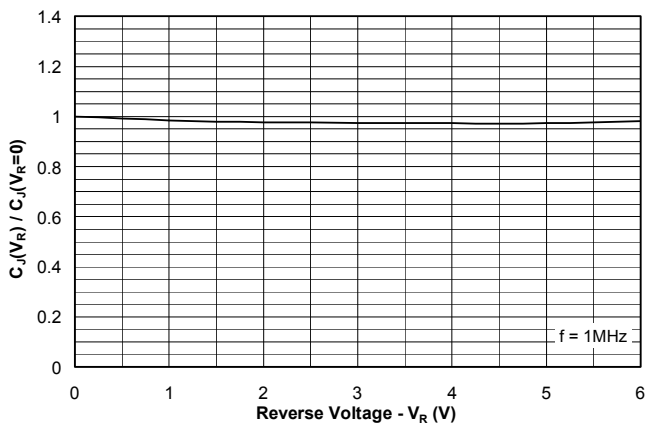

Forward Voltage vs. Forward Current

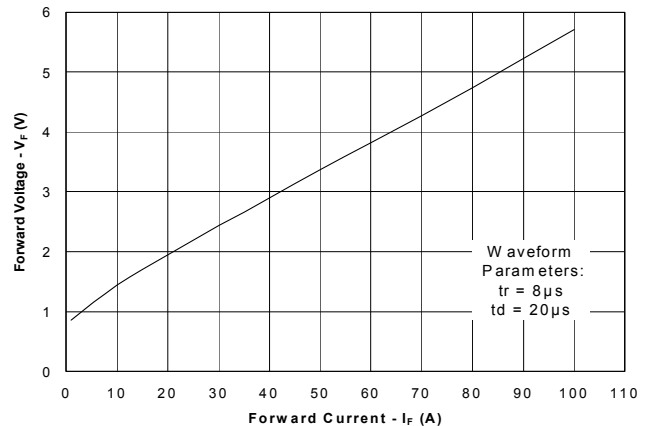

PROTECTION PRODUCTS

Typical Characteristics

Insertion Loss S21 - I/O to I/O

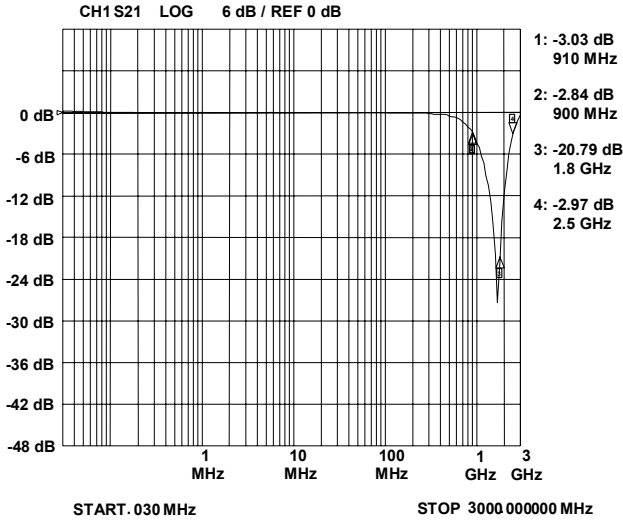

Insertion Loss S21 - I/O to Gnd

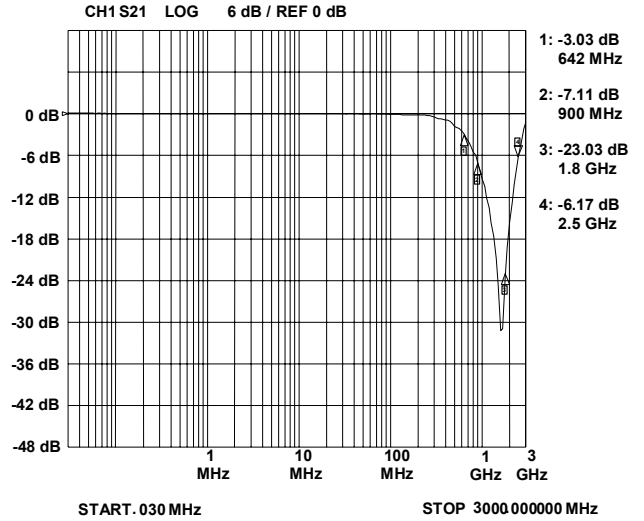

PROTECTION PRODUCTS

Applications Information

Device Connection Options for Protection of Two High-Speed Data Lines

The LC03-6 is designed to protect two high-speed data lines (one differential pair) from transient over-voltages which result from lightning and ESD. The device can be configured to protect in differential (Line-to-Line) and common (Line-to-Ground) mode. Data line inputs/outputs are connected at pins 1 to 8, and 4 to 5 as shown. Pins 2, 3, 6, and 7 are connected to ground. These pins should be connected directly to a ground plane on the board for best results. The path length is kept as short as possible to minimize parasitic inductance. In applications where high common mode voltages are present, differential protection is achieved by leaving pins 2, 3, 6, and 7 not connected.

Connection for Differential (Line-to-Line) and Common Mode Protection (Line-to-Ground)

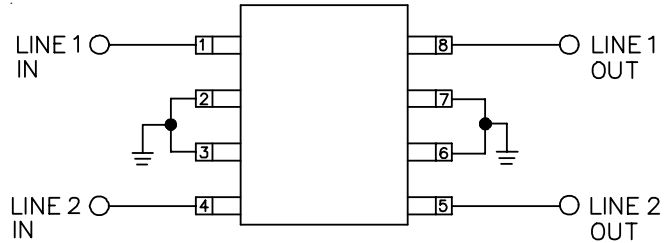

Connection for Differential Protection (Line-to-Line)

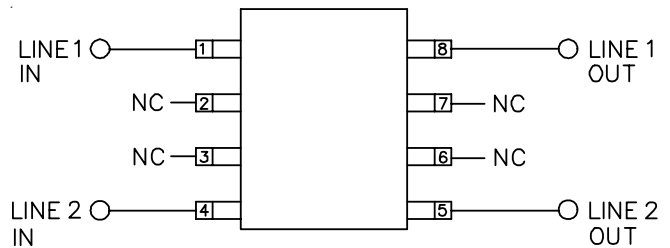

T1/E1 Linecard Protection (Intra-Building)

A typical T1/E1 linecard protection circuit is shown below. The LC03-6 is connected between Tip and Ring on the transmit and receive line pairs. It provides protection to metallic and common mode lightning surges per Bellcore 1089. This design takes advantage of the isolation of the transformer to suppress common mode surges. To complete the protection circuit, the RClamp3304N (or RClamp0504N for 5V supplies) is employed as the IC side protection element. This device helps prevent the transceiver from latching up by providing fine clamping of transients that are coupled through the transformer. For further information, reference Semtech application note AN97-10.

T3/E3 and STS-1 Protection

The LC03-6 can also be used to protect T3/E3 and STS-1 interfaces. The data lines from the BNC interface are run through the LC03-6 (i.e. enters at pin 1 and exits at pin 8) with the ground connection made at the other side of the device (pins 4 and 5). The center pins (2, 3, 6, and 7) are not connected. In this configuration, the LC03-6 adds less than 12pF of capacitance to each line and provides surge protection to 100A (tp=8/20µs).

Matte Tin Lead Finish

Matte tin has become the industry standard lead-free replacement for SnPb lead finishes. A matte tin finish is composed of 100% tin solder with large grains. Since the solder volume on the leads is small compared to the solder paste volume that is placed on the land pattern of the PCB, the reflow profile will be determined by the requirements of the solder paste. Therefore, these devices are compatible with both lead-free and SnPb assembly techniques. In addition, unlike other lead-free compositions, matte tin does not have any added alloys that can cause degradation of the solder joint.

PROTECTION PRODUCTS

Typical Applications

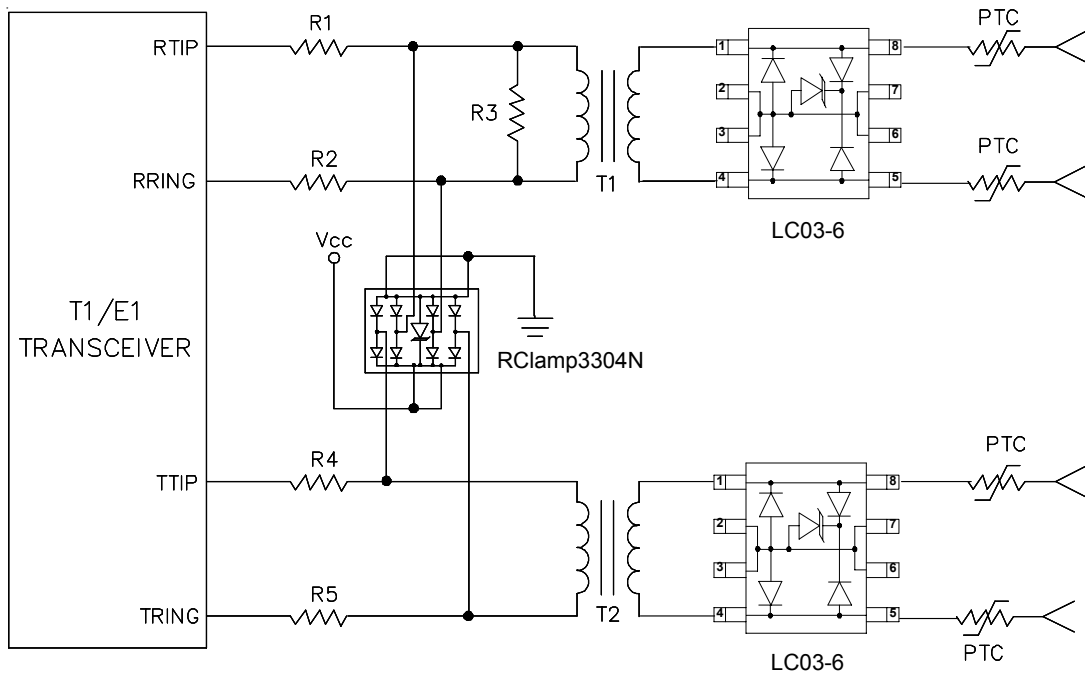

T1 Line Card Protection (Short-Haul Applications)

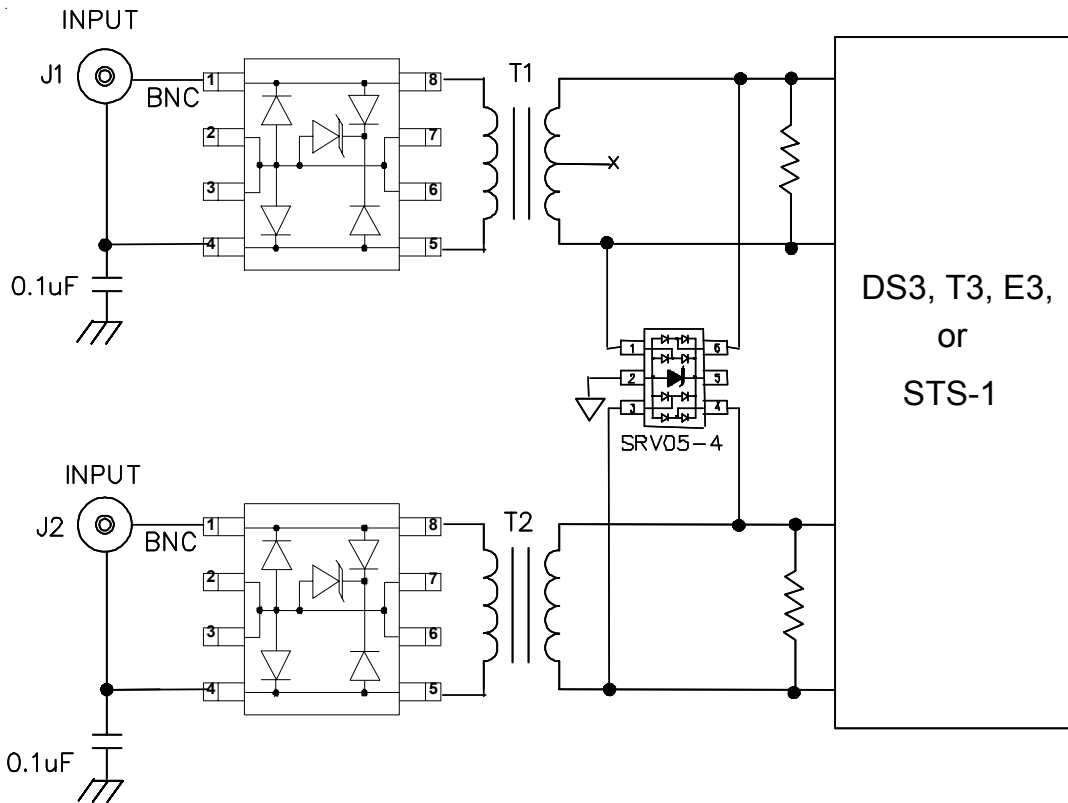

T3/E3 and STS-1 Protection

PROTECTION PRODUCTS

Typical Applications (Continued)

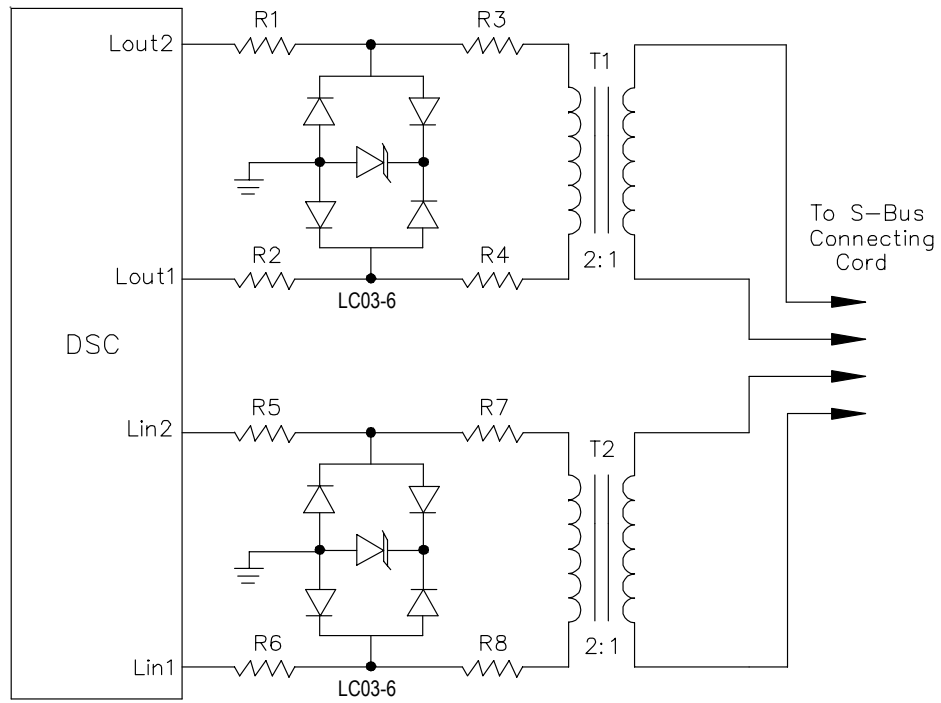

ISDN S-Interface Protection

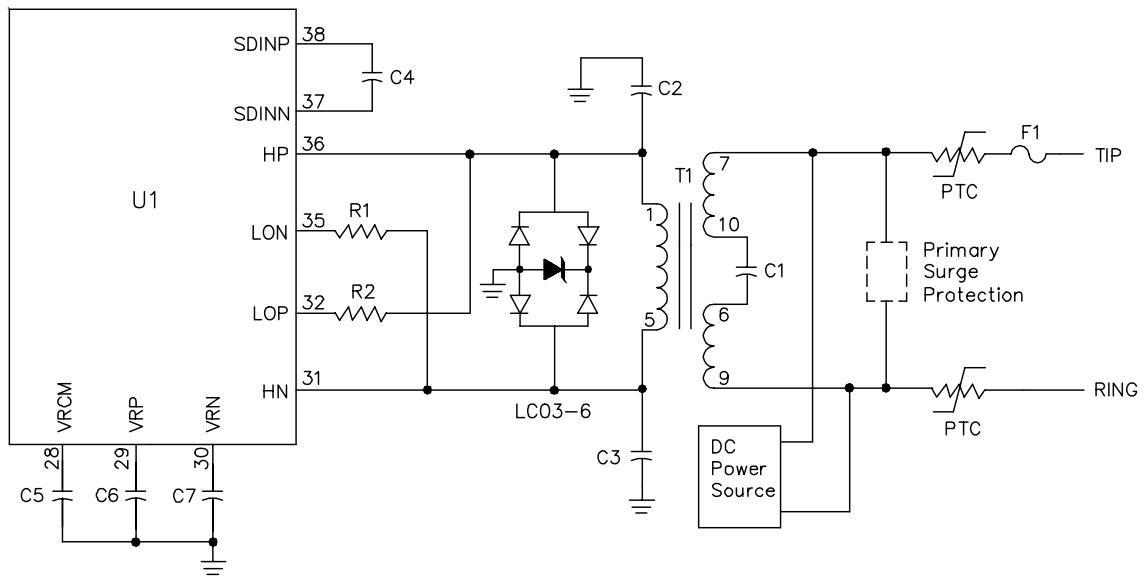

ISDN U-Interface Secondary Protection

PROTECTION PRODUCTS

Typical Applications (Continued)

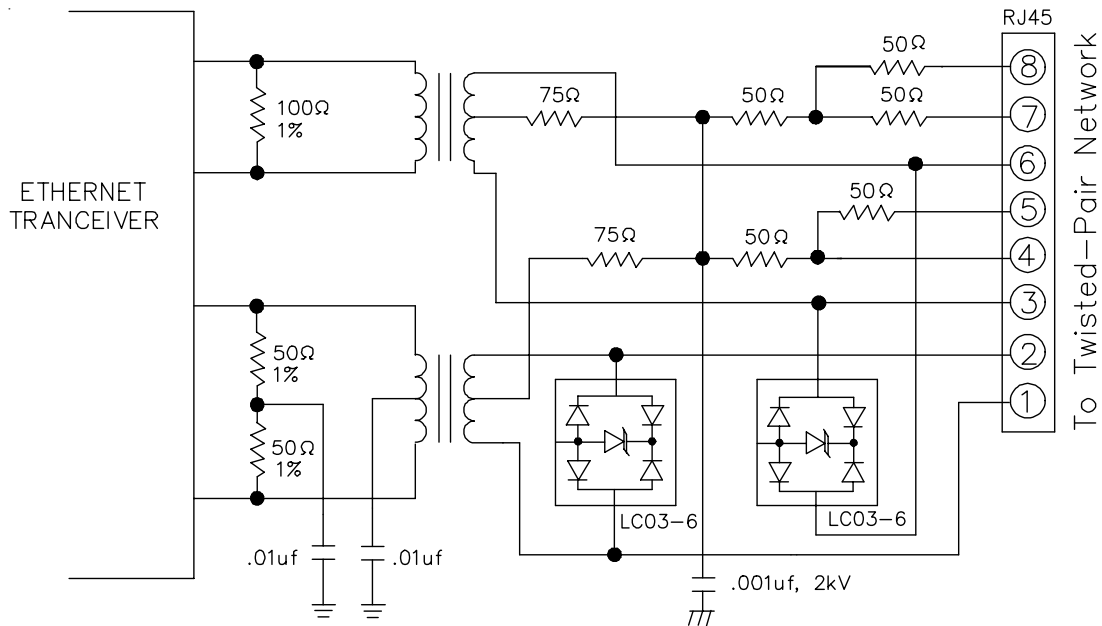

10/100 Ethernet Protection

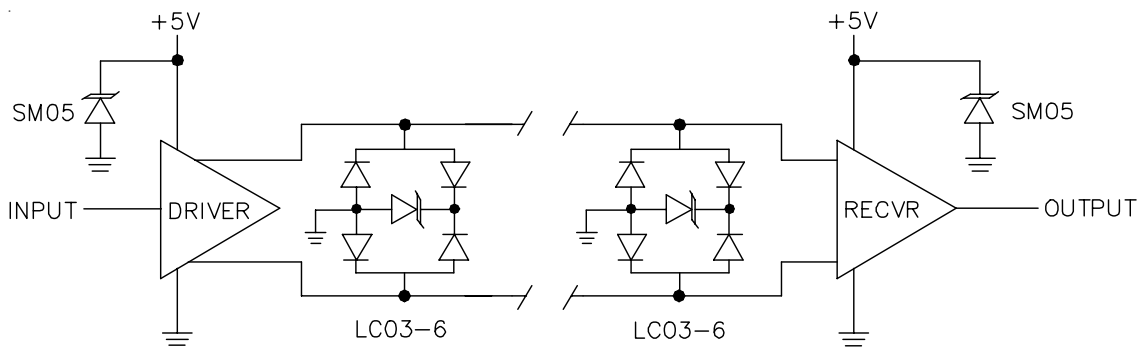

High Speed Driver/Receiver Protection

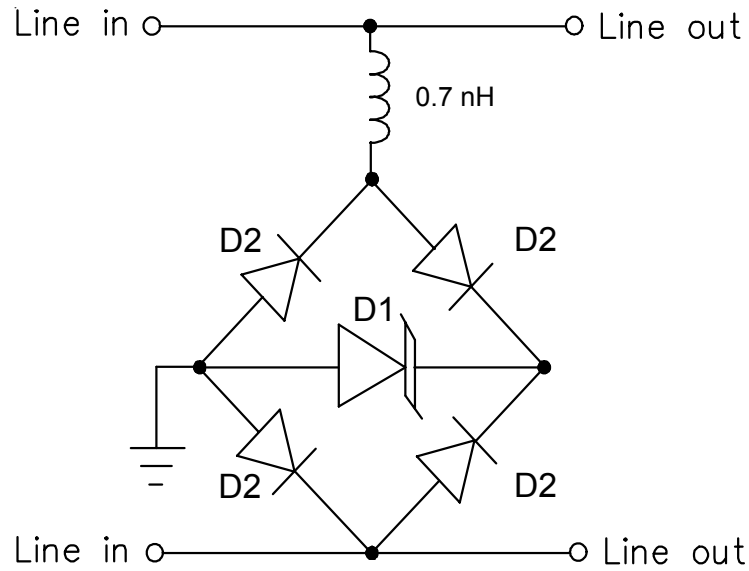
PROTECTION PRODUCTS
Applications Information - SPICE Model

LC03-6 Spice Model

LC03-6 Spice Parameters			
Parameter	Unit	D1 (TVS)	D2 (LCRD)
IS	Amp	1.0E-20	3.98E-13
BV	Volt	7.9	240
VJ	Volt	0.6	0.64
RS	Ohm	0.102	0.048
IBV	Amp	1E-3	1E-3
CJO	Farad	3.4e-9	8.0E-12
TT	sec	2.541E-9	2.541E-9
M	--	0.007	0.022
N	--	1.1	1.1
EG	eV	1.11	1.11

PROTECTION PRODUCTS**Ordering Information**

Part Number	Lead Finish	Qty per Reel	Reel Size
LC03-6.TB	SnPb	500	7 Inch
LC03-6.TBT	Pb free	500	7 Inch

Contact Information

Semtech Corporation
Protection Products Division
200 Flynn Rd., Camarillo, CA 93012
Phone: (805)498-2111 FAX (805)498-3804