

## CURRENT MODE PWM CONTROLLER WITH BUILT-IN HIGH VOLTAGE MOSFET

### DESCRIPTION

SW253G is a current mode PWM controller with low standby power and low start current for power switch. In standby mode, the circuit enters burst mode to reduce the standby power dissipation.

The switch frequency is 67KHz with  $\pm 2.5$  KHz jitter frequency for low EMI.

The stress on transformer during power on is reduced by the built-in 15ms soft start circuit to avoid the saturation of transformer.

SW253G includes under voltage lock-out, over voltage protection, leading edge blanking, over current protection and the temperature protection. The circuit will restart automatically until the system is normal after the protection is active.

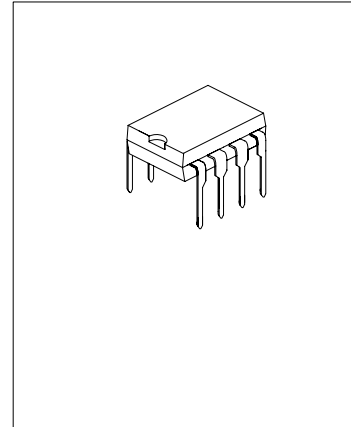

### FEATURES

- \* Lower start-up current (Typ. 6 $\mu$ A)
- \* Frequency jitter for low EMI
- \* Overcurrent protection
- \* Overvoltage protection
- \* Undervoltage lockout
- \* Built-in temperature protection
- \* Built-in high voltage MOSFET
- \* Auto restart mode
- \* Built-in soft start
- \* Burst mode operation
- \* Cycle by cycle current limit

### APPLICATIONS

- \* Switch power

### ORDERING INFORMATION

Part No.	Package	Marking
SW253GP67K65	DIP-8-300-2.54	SW253G

Note: P denotes it is available in DIP8 package, 67k denotes 67KHz, and 65 denotes withstand voltage is 650V.

## TYPICAL OUPUT POWER CAPABILITY

Device	190~265VAC		85~265VAC	
	Adapter	Open	Adapter	Open
SW253GP67K65	21W	25W	18W	21W

## BLOCK DIAGRAM

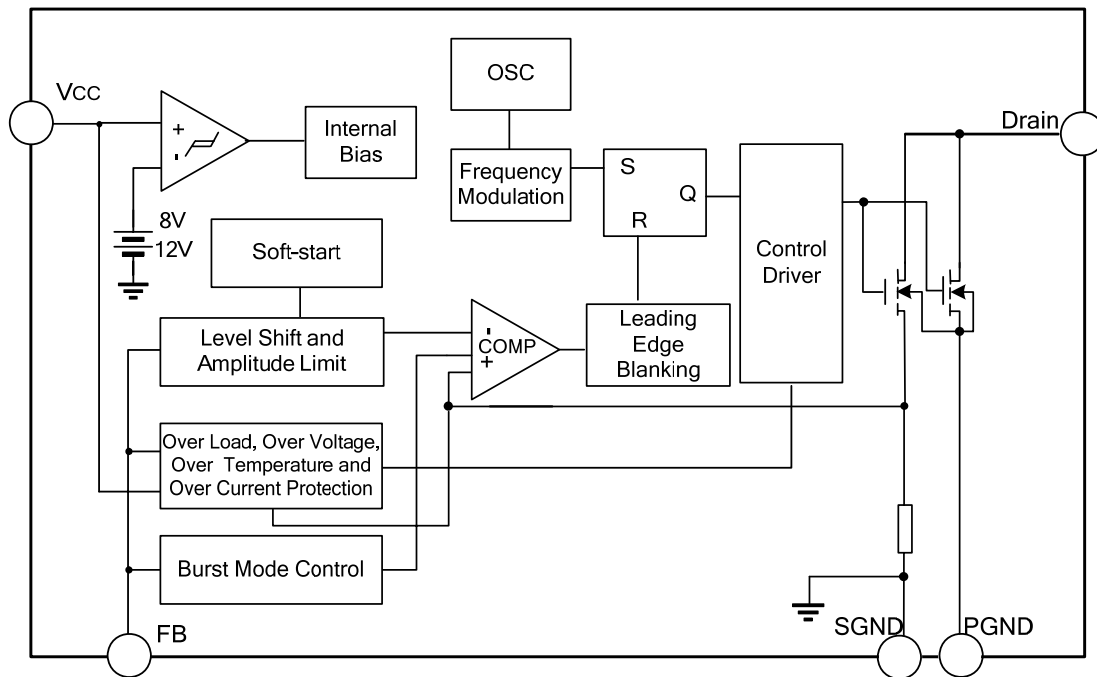

## ABSOLUTE MAXIMUM RATING

Characteristics		Symbol	Rating	Unit
Drain-Gate Voltage (RGS=1MΩ)		VDGR	650	V
Gate-Source (GND) Voltage		VGS	±30	V
Drain Current Pulse (note1)	SW253GP67K65	IDM	14	A

Characteristics		Symbol	Rating	Unit
Continuous Drain Current (T <sub>amb</sub> =25°C)	SW253GP67K65	I <sub>D</sub>	4	A
Signal Pulse Avalanche Energy(note 2)	SW253GP67K65	EAS	200	mJ
Power Supply Voltage		V <sub>CC,MAX</sub>	21	V
Analog Input Voltage		V <sub>FB</sub>	-0.3~ V <sub>SD</sub>	V
Total Power Dissipation		P <sub>D</sub>	1.4	W
		Darting	0.017	W/°C
Operating Junction Temperature		T <sub>J</sub>	+160	°C
Operating Temperature		T <sub>amb</sub>	-25~ +85	°C
Storage Temperature		T <sub>STG</sub>	-55~+150	°C

Note: 1. Pulse width is limited by maximum junction temperature.

2. L=51mH, starting T<sub>j</sub>=25°C

### ELECTRICAL CHARACTERISTICS (sense MOSFET part, unless otherwise specified, T<sub>amb</sub>=25°C)

Characteristics	Symbol	Test conditions	Min.	Typ.	Max.	Unit
Drain-Source Breakdown Voltage	BV <sub>DSS</sub>	V <sub>GS</sub> =0V, I <sub>D</sub> =50μA	650	--	--	V
Zero Gate Voltage Drain Current	I <sub>DSS</sub>	V <sub>DS</sub> =Max. V <sub>GS</sub> =0V	--	--	50	μA
		V <sub>DS</sub> =0.8Max. V <sub>GS</sub> =0V T <sub>amb</sub> =125°C	--	--	200	μA
Static Drain- Source On Resistance	SW253GP67K65	R <sub>DS(ON)</sub> V <sub>GS</sub> =10V, I <sub>D</sub> =0.5A	--	3.0	3.6	Ω
Input Capacitance	SW253GP67K65	C <sub>iss</sub> V <sub>GS</sub> =0V, V <sub>DS</sub> =25V, f=1MHz	--	840	--	pF
Output Capacitance	SW253GP67K65	C <sub>oss</sub> V <sub>GS</sub> =0V, V <sub>DS</sub> =25V, f=1MHz	--	44	--	pF

Characteristics	Symbol	Test conditions	Min.	Typ.	Max.	Unit
Reverse Transfer Capacitance	SW253GP67K65 Crss	VGS=0V, VDS=25V, f=1MHz	--	40	--	pF
Turn On Delay Time	SW253GP67K65 td(ON)	VDD=0.5BV <sub>DSS</sub> , ID=25mA	--	40	--	nS
Rise Time	SW253GP67K65 tr	VDD=0.5BV <sub>DSS</sub> , ID=25mA	--	25	--	nS
Turn Off Delay Time	SW253GP67K65 td(OFF)	VDD=0.5BV <sub>DSS</sub> , ID=25mA	--	90	--	nS
Fall Time	SW253GP67K65 tf	VDD=0.5BV <sub>DSS</sub> , ID=25mA	--	42	--	nS

**ELECTRICAL CHARACTERISTICS** (unless otherwise specified, T<sub>amb</sub>=25°C)

Characteristics	Symbol	Test conditions	Min.	Typ.	Max.	Unit
<b>Undervoltage Section</b>						
Start Threshold Voltage	V <sub>start</sub>		11	12	13	V
Stop Threshold Voltage	V <sub>stop</sub>		7	8	9	V
<b>Oscillator Section</b>						
Oscillate Frequency	F <sub>OSC</sub>		61	67	73	KHz
Frequency Jitter	F <sub>MOD</sub>		±1.5	±2.0	±2.5	KHz
Frequency Change With Temperature	--	25°C ≤ T <sub>amb</sub> ≤ +85°C	--	±5	±10	%
Maximum Duty Cycle	D <sub>max</sub>		72	77	82	%
<b>Feedback Section</b>						
Feedback Source Current	I <sub>FB</sub>	0V ≤ V <sub>FB</sub> ≤ 3V	0.7	0.9	1.1	mA
Shutdown Feedback Voltage	V <sub>SD</sub>		5.5	6.0	6.5	V
Shutdown Delay Current	I <sub>delay</sub>	5V ≤ V <sub>FB</sub> ≤ V <sub>SD</sub>	3.5	5.0	6.5	μA

Characteristics	Symbol	Test conditions	Min.	Typ.	Max.	Unit	
Built-in Soft Start Time	$t_s$	VFB=4V	10	15	20	ms	
<b>Current Limit</b>							
Peak Current Limit	SW253GP67K65	lover	Max. inductor current	1.35	1.50	1.65	A
<b>Burst mode</b>							
Burst Mode High Voltage	VBURH		0.4	0.5	0.6	V	
Burst Mode Low Voltage	VBURL		0.25	0.35	0.45	V	
<b>Protection Section</b>							
Overvoltage Protection	Vovp		18	19	--	V	
Thermal Shutdown	Tsd		125	140	--	°C	
Leading-edge Blanking Time	TLEB		200	--	--	ns	
<b>Total Standby Current</b>							
Start Current	Istart	VCC=11V	--	6	20	μA	
Supply Current (Control Part)	Iop	VCC=12V	1	3	5	mA	

## PIN CONFIGURATION

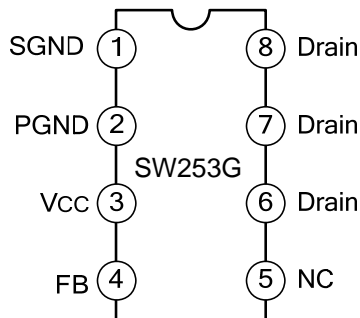

## PIN DESCRIPTION

Pin No.	Pin Name	I/O	Function description
1	SGND	-	Ground for control part.
2	PGND	-	MOSFET Ground.
3	VCC	-	Power supply pin.
4	FB	I/O	Feedback input pin.
5	NC	-	Not connected.
6,7,8	Drain	O	Drain pins.

## FUNCTION DESCRIPTION

SW253G is designed for off-line SMPS, consisting of high voltage MOSFET, optimized gate driver and current mode PWM controller which includes frequency oscillator and various protections such as undervoltage lockout, overvoltage protection, overcurrent protection and overtemperature protection. Frequency jitter generated from oscillator is used to lower EMI and built-in soft start is used for reducing transformer stress when the circuit is powered on. Burst mode is adopted during light load to lower standby power dissipation, and function of lead edge blanking eliminates the MOSFET error shutdown caused by interference through minimizing MOSFET turning on time. Few peripheral components are needed for higher efficiency and higher reliability and it is suitable for flyback converter and forward converter.

### 1. Under Voltage Lockout and Self-Start

At the beginning, the capacitor connected to pin VCC is charged via start resistor by high voltage AC and the circuit start to work if voltage at Vcc is 12V. The output is shutdown if there is any protection during normal operation and Vcc is decreased because of powering of auxiliary winding. The whole control circuit is shutdown if voltage at Vcc is 8V below to lower current dissipation and the capacitor is recharged for restarting.

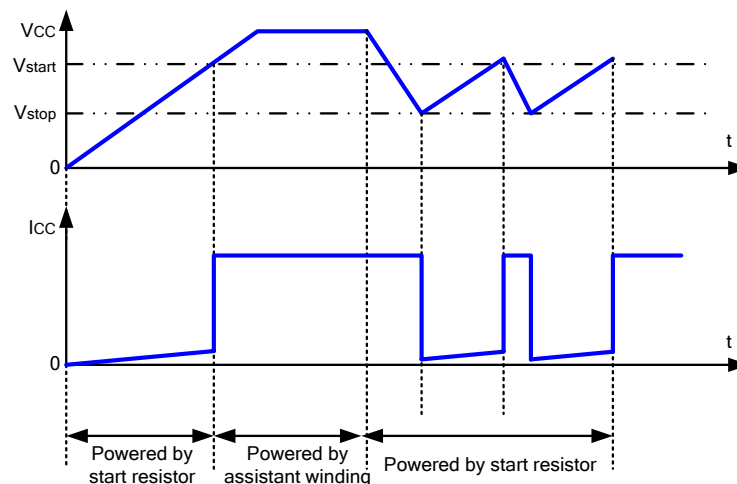

### 2. Built-In Soft Start Circuit

In order to decrease transformer stress and to prevent its saturation during power on, it is recommended to increase peak current value of primary winding slowly by increasing feedback voltage slowly. After about 15ms, the soft start is completed and it has no effect on normal operation.

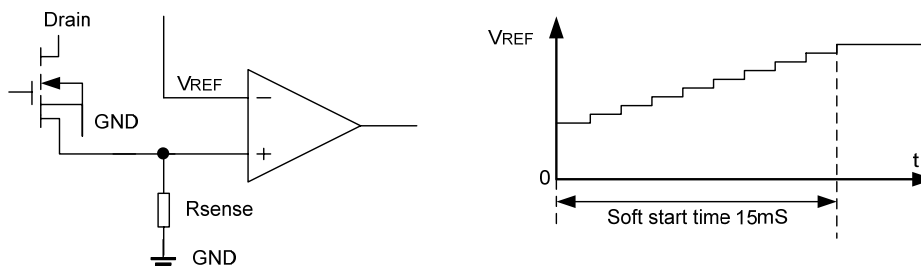

### 3. Frequency Jitter

The oscillation frequency is kept changed for low EMI and decreasing radiation on one frequency. The oscillation frequency changes within a very small range to simplify EMI design. The rule of frequency changing: change from 65KHz to 69KHz.

### 4. Light Load Mode

Working in this mode to reduce power dissipation. It works normally when FB is 500mV above and during  $350\text{mV} < \text{FB} < 500\text{mV}$ , there are two different conditions: when FB changes from low to high, there is no action for switch and it is the same with condition of FB lower than 350mV; the other is that FB changes from high to low, comparison value is increased for increasing turning on time to decrease switch loss.

For this mode, during FB changes from high to low, the output voltage increases (increasing speed is decided by load) because of the high comparison value to decrease FB until it is 350mV below; when  $\text{FB} < 350\text{mV}$ , there is no action for switch and output voltage decrease (decreasing speed is also decided by load) to increase FB. This is repeated to decrease action of switch for lower power dissipation.

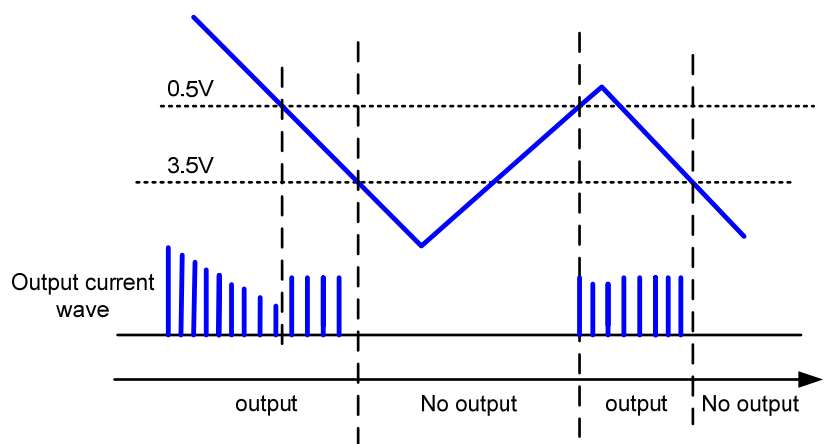

### 5. Leading Edge Blanking

For this current-controlled circuit, there is pulse peak current during the transient of switch turning on and there is an error operation if the current is sampled during this time. And leading edge blanking is adopted to eliminate this error operation. The output of PWM comparator is used for controlling shutdown after the leading edge blanking if there is any output drive.

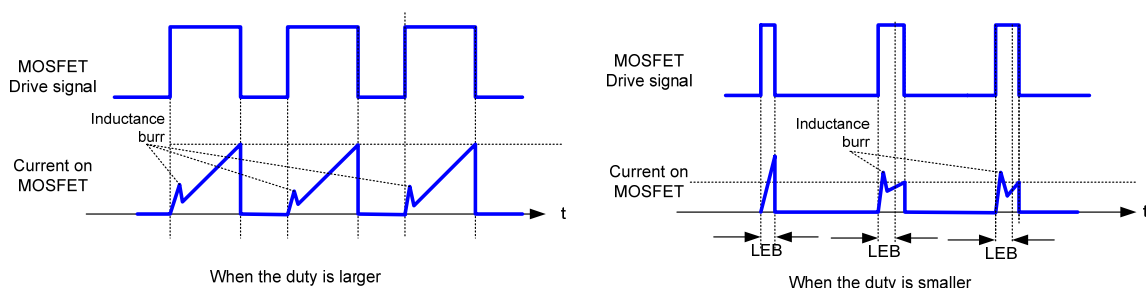

### 6. Over Voltage Protection

The output is shutdown if voltage at Vcc exceeds the threshold and this state is kept until the circuit is powered on reset.

## 7. Overload Protection

FB voltage increase if there is overload and the output is shutdown when FB voltage is up to the feedback shutdown voltage. This state is kept until the circuit is powered on reset.

## 8. Peak Current Limit Cycle By Cycle

During each cycle, the peak current value is decided by the comparison value of the comparator, which will not exceed the peak current limited value to guarantee the current on MOSFET will not be more than the rating current. The output power will not increase if the current reaches the peak value to limit the max. output power. The output voltage decreases and FB voltage increases if there is overload and corresponding protection occurs.

## 9. Abnormal Over Current Protection

That secondary diode is short, or the transformer is short will cause this event. At this time, once it is over current in spite of the leading edge blanking (L.E.B) time, protection will begin after 350nS, and is active for every cycle. When the voltage on the current sense resistor is 1.6V, this protection will occur and the output is shut down. This state is kept until the under voltage occurs, and the circuit will start.

## 10. Thermal Shutdown

If the circuit is over temperature, the over temperature protection will shut down the output to prevent the circuit from damage. This state is kept until the under voltage occurs, and the circuit will start.



## TYPICAL APPLICATION CIRCUIT

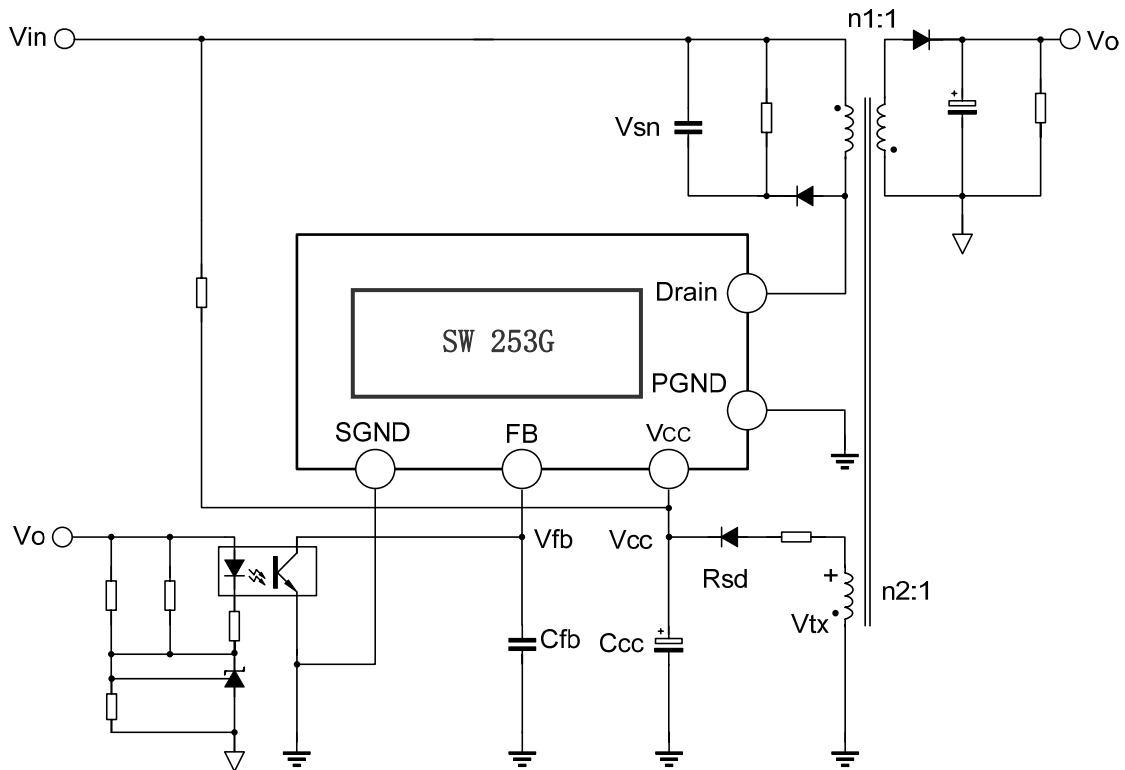

Note: The circuit and parameters are for reference only, please set the parameters of the real application circuit based on the real test.

## PACKAGE OUTLINE

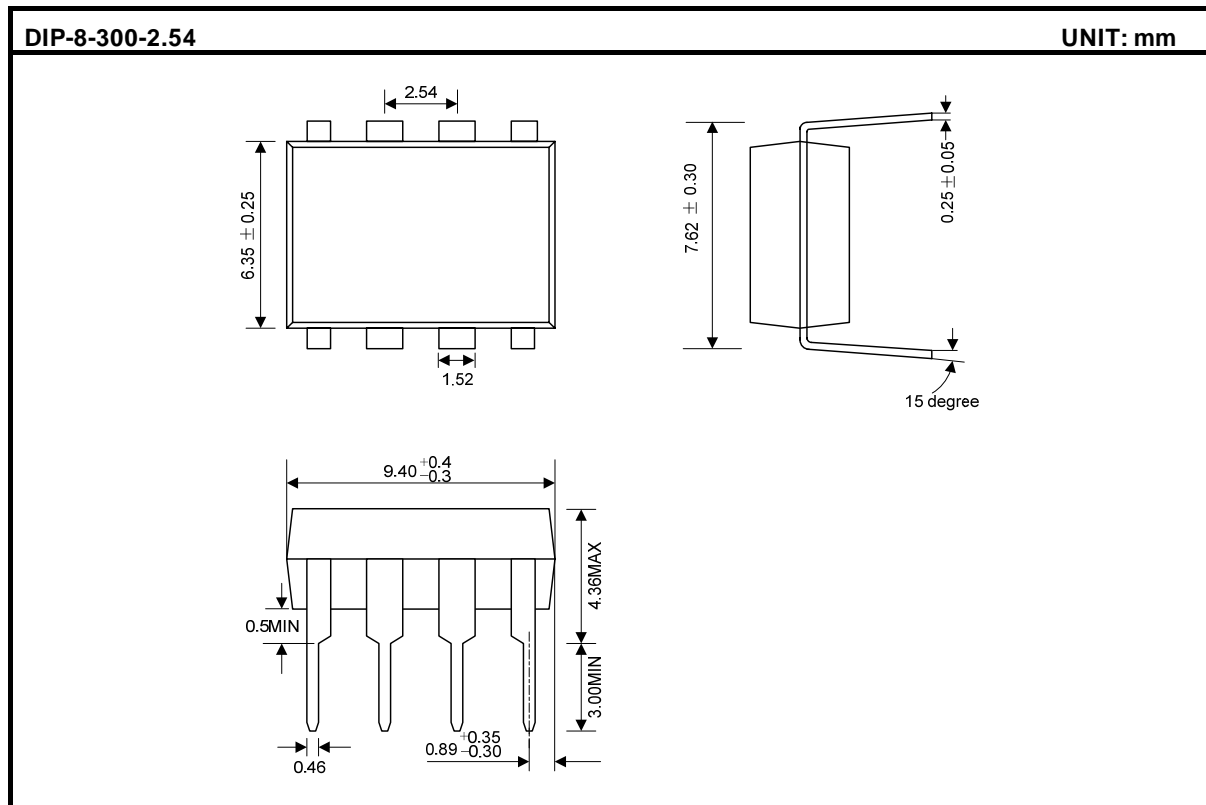

### MOS DEVICES OPERATE NOTES:

Electrostatic charges may exist in many things. Please take following preventive measures to prevent effectively the MOS electric circuit as a result of the damage which is caused by discharge:

- The operator must put on wrist strap which should be earthed to against electrostatic.
- Equipment cases should be earthed.
- All tools used during assembly, including soldering tools and solder baths, must be earthed.
- MOS devices should be packed in antistatic/conductive containers for transportation.

Note: Samwin reserves the right to make changes without notice in this specification for the improvement of the design and performance. Samwin will supply the best possible product for customers.