

# AN7332K/S

## Dual 4-Bands Graphic Equalizer IC

### ■ Description

The AN7332K/S are the monolithic integrated circuits designed for dual 4-bands graphic equalizer most suitably used for radio cassette recorder and portable stereo set. Two channel 4-bands graphic equalizer can be composed by applying resonance frequency setting capacitor and variable resistor externally. Boost and cutting quantity is adjusted.

### ■ Features

- Wide operating supply voltage range:  
 $V_{CC} = 3V \sim 14.4V$
- The resonance frequency is fixed by using suitable capacitors
- Dual-channel IC make compact circuit design possible
- Low current consumption: 2.8mA type ( $V_{CC} = 5V$ )

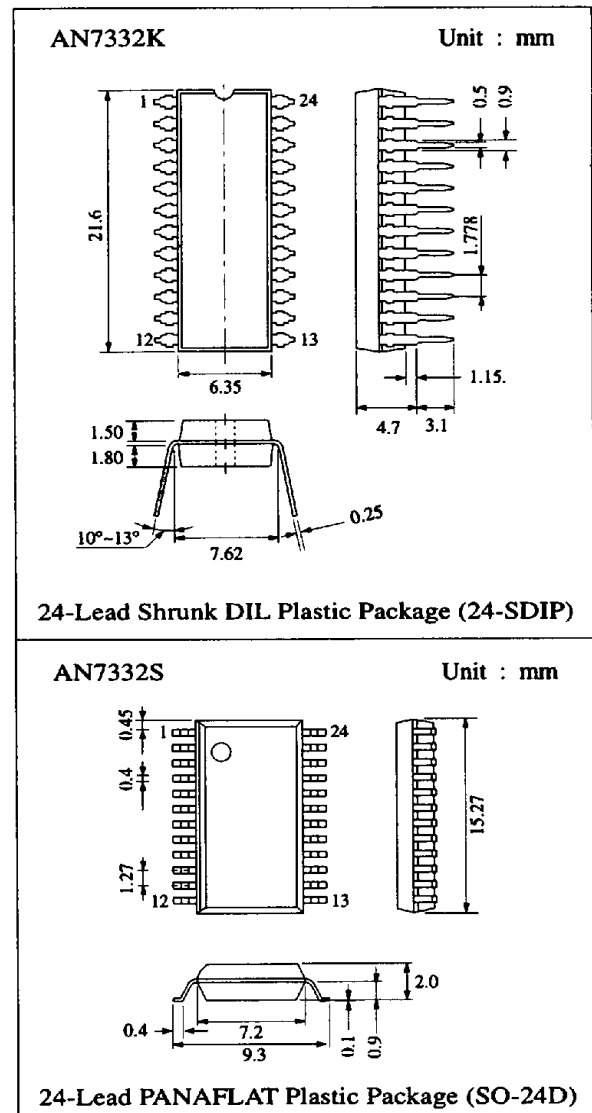

### ■ Block Diagram

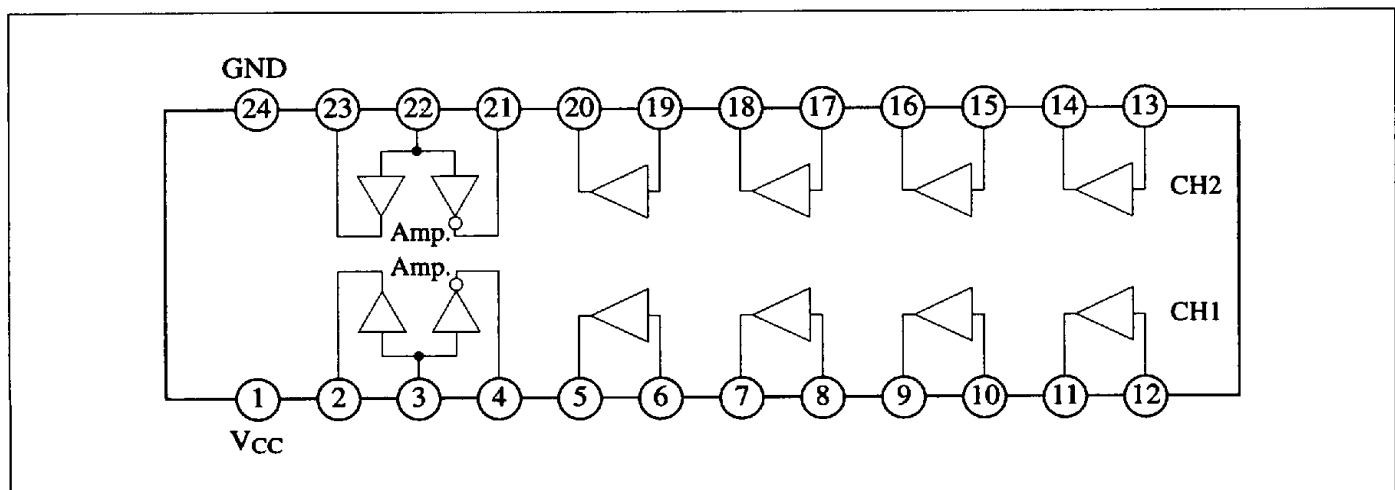

### ■ Absolute Maximum Ratings (Ta=25°C)

Item	Symbol	Rating	Unit
Supply Voltage	V <sub>CC</sub>	14.4	V
Supply Current	I <sub>CC</sub>	30	mA
Power Dissipation	P <sub>D</sub>	432	mW
Operating Ambient Temperature	Topr	-20 ~ +75	°C
Storage Temperature	Tstg	-55 ~ +125	°C

Operating Supply Voltage Range: V<sub>CC</sub> = 3.0V ~ 14.4V

### ■ Electrical Characteristics (V<sub>CC</sub>=5V, R<sub>g</sub>=10kΩ, Ta=25°C)

Item	Symbol	Condition	min.	typ.	max.	Unit
Total Circuit Current (1)	I <sub>tot1</sub>	V <sub>CC</sub> = 5V	1.6	2.8	4.0	mA
Total Circuit Current (2)	I <sub>tot2</sub>	V <sub>CC</sub> = 9V	2.0	3.8	5.5	mA
Voltage Gain	G <sub>V</sub>	f = 1kHz, All Flat, V <sub>O</sub> = -20dB		-3		dB
Boost Quantity*	Boost	f = 100Hz	6.5	8.5		dB
Boost Quantity*	Boost	f = 340Hz	6.5	8.5		dB
Boost Quantity*	Boost	f = 1kHz	6.5	8.5		dB
Boost Quantity*	Boost	f = 3.4kHz	6.5	8.5		dB
Cutting Quantity*	Cut	f = 100Hz	-7.5	-9.5		dB
Cutting Quantity*	Cut	f = 340Hz	-7.5	-9.5		dB
Cutting Quantity*	Cut	f = 1kHz	-7.5	-9.5		dB
Cutting Quantity*	Cut	f = 3.4kHz	-7.5	-9.5		dB
Total Harmonic Distortion	THD	f = 1kHz, V <sub>O</sub> = -20dB		0.2	0.4	%
Output Noise Voltage	V <sub>no</sub>	R <sub>g</sub> = 0Ω, All Flat, DIN/AUDIO		15		μV
Crosstalk	CT	f = 1kHz, All Flat, R <sub>g</sub> = 0Ω		-64		dB

Boost and cutting quantity show the value when each element is operated.

\*V<sub>O</sub> = -20dB = 0dB reference at 'all flat' equalizer setting.

### ■ Pin

Pin No	Pin Name	Pin No	Pin Name
1	V <sub>CC</sub>	13	Base 4 Ch.2
2	Non-inverting Output Ch.1	14	Negative Feedback 4 Ch.2
3	Input Ch.1	15	Base 3 Ch.2
4	Inverting Output Ch.1	16	Negative Feedback 3 Ch.2
5	Negative Feedback 1 Ch.1	17	Base 2 Ch.2
6	Base 1 Ch.1	18	Negative Feedback 2 Ch.2
7	Negative Feedback 2 Ch.1	19	Base 1 Ch.2
8	Base 2 Ch.1	20	Negative Feedback 1 Ch.2
9	Negative Feedback 3 Ch.1	21	Inverting Output Ch.2
10	Base 3 Ch.1	22	Input Ch.2
11	Negative Feedback 4 Ch.1	23	Non Inverting Output Ch.2
12	Base 4 Ch.1	24	GND

Test Circuit

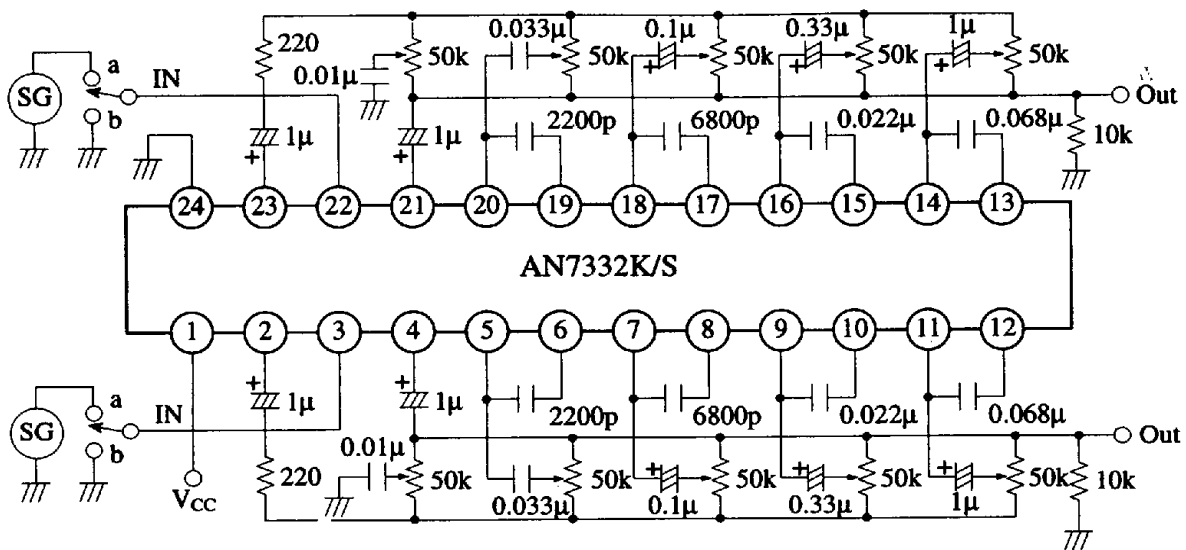

Application Circuit

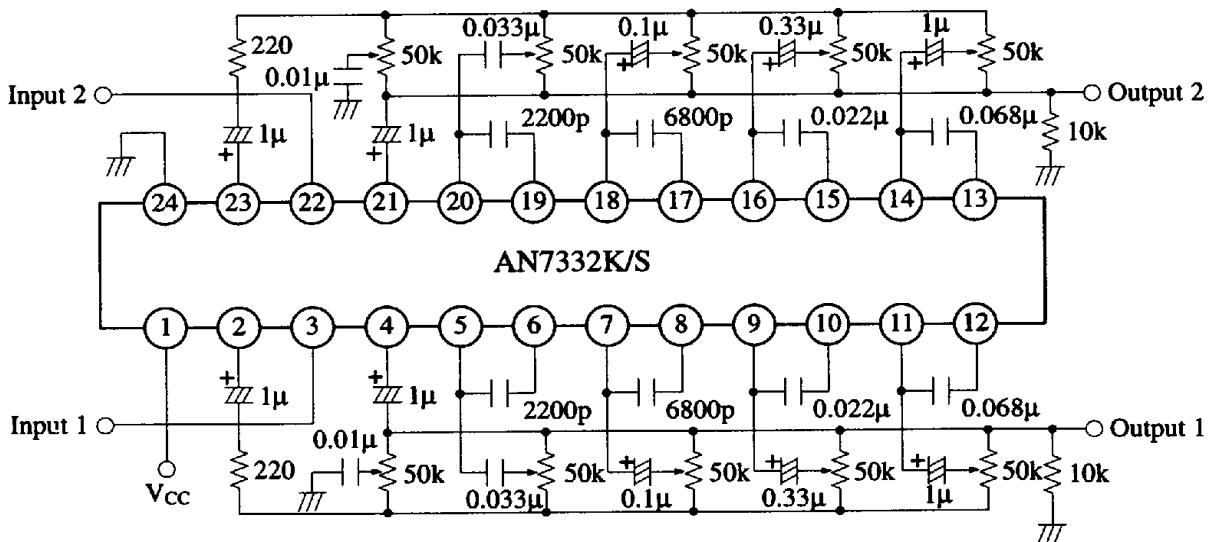

Characteristics Curve

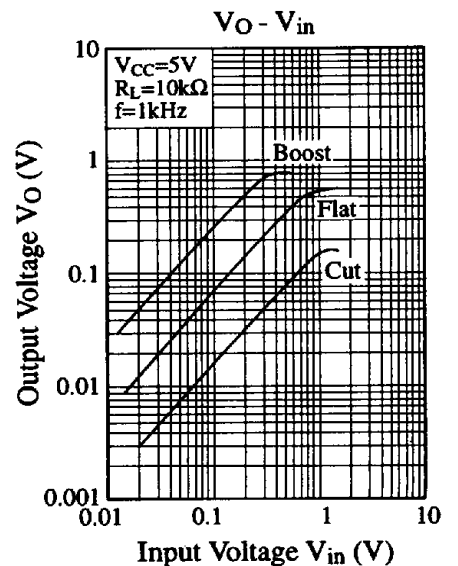
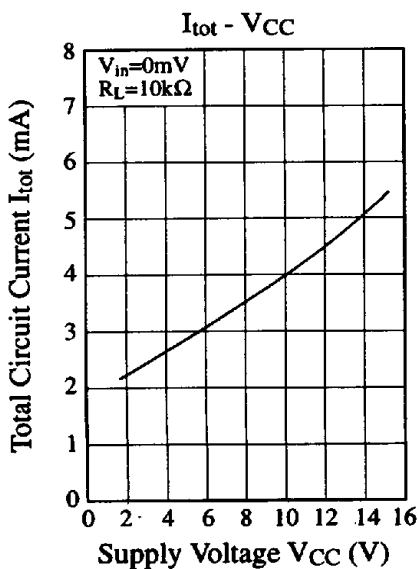

■ Characteristics Curve (Continue)

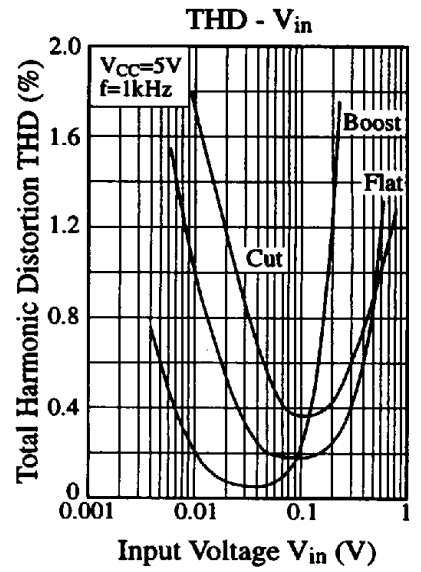
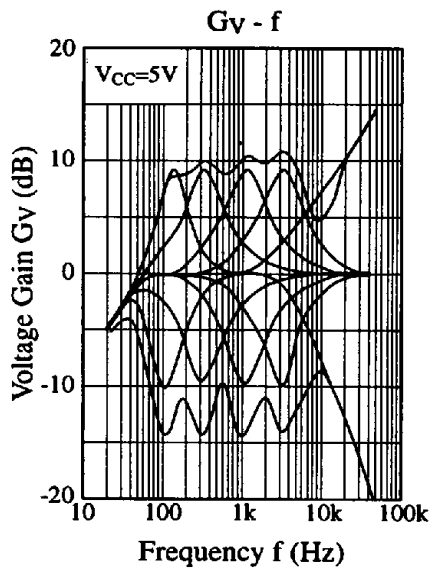

■ Printed Circuit Board Layout (Scale: 1:1)

