

THIS DRAWING IS UNPUBLISHED. RELEASED FOR PUBLICATION NOV. 2001.
 © COPYRIGHT 2001 By - ALL RIGHTS RESERVED.

LOC	DIST	REVISIONS					
J		P	LTR	DESCRIPTION	DATE	DWN	APVD
			J3	REVISED PER ECR-16-002212	15FEB16	S.Z	S.L

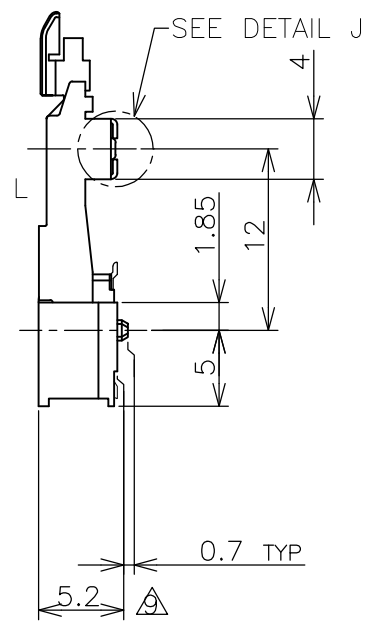

- (APPLIED TO SHEET 1-2)
- MATERIAL ; HOUSING: HIGH TEMPERATURE THERMO PLASTIC UL94V-0
CONTACT: COPPER ARROY
LOCK LEVER: STAINLESS STEEL
SOLDER PEG: COPPER ARROY
 - FINISH ; CONTACT AREA: GOLD FLASH ON 0.0013MIN ALL OVER NICKEL.
SOLDERING AREA: GOLD FLASH PLT.
SOLDER PEG: TIN PLATING.
 - MECHANICAL KEY POSITION OF CONNECTOR SEE TABLE.
 - TOLERANCES NON-CUMULATIVE.
 - NOT TO SCALE.
 - INSIDE MUST BE RESIST COAT EXCEPT SOLDER PATTERN.
 - COPLANARITY : 0.1 MAX.
 - THE FLOATING VALUE BY SOLDERING IS NOT INCLUDED.
 - NOT MATING CONDITION.
 - FINISH ; CONTACT AREA: 0.00076 GOLD ON 0.0013MIN ALL OVER NICKEL.
SOLDERING AREA: 0.00076 GOLD PLT.
SOLDER PEG: TIN PLATING.
- 11 IF THE MODULE DOESN'T INSERT AND LOCK IN THE LATCH SMOOTHLY, OPEN WIDE BOTH LATCHES BY MANUAL. AND THE MODULE MUST BE INSERTED AND LOCKED IN THE LATCH.

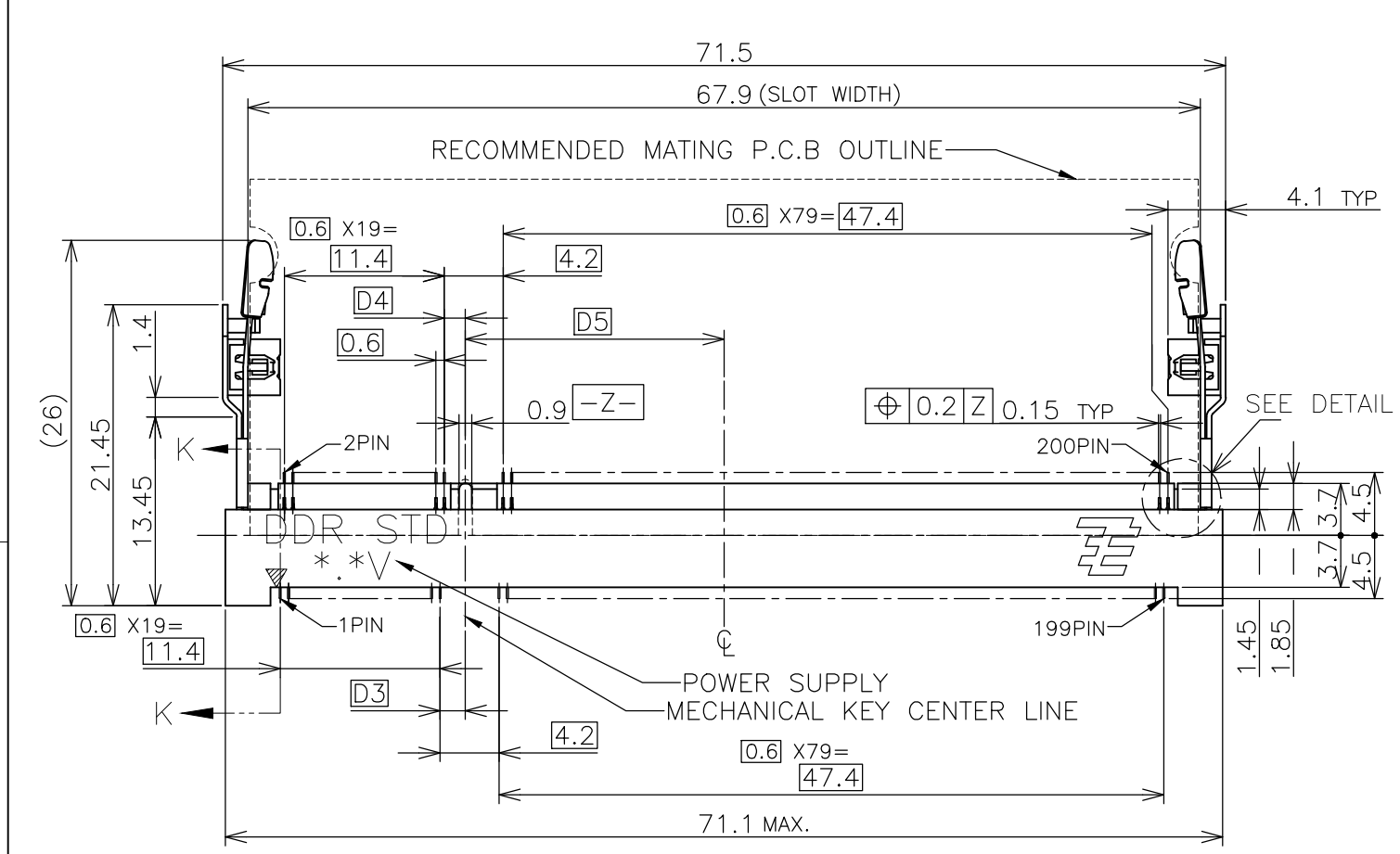
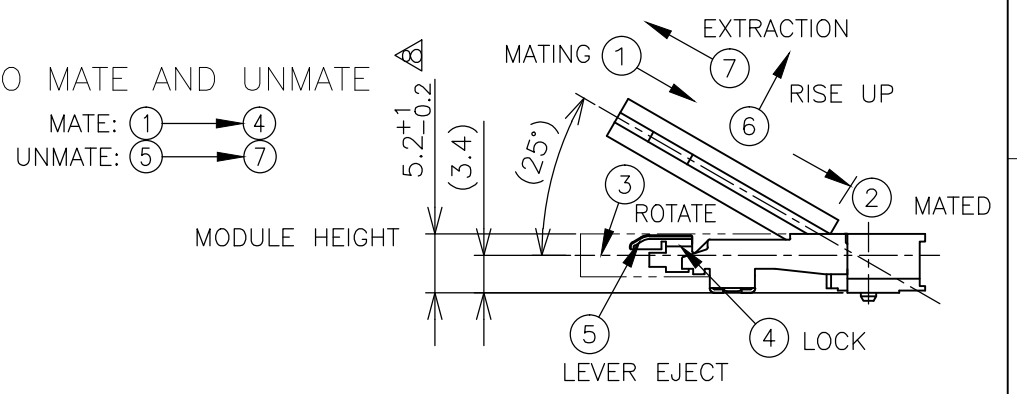
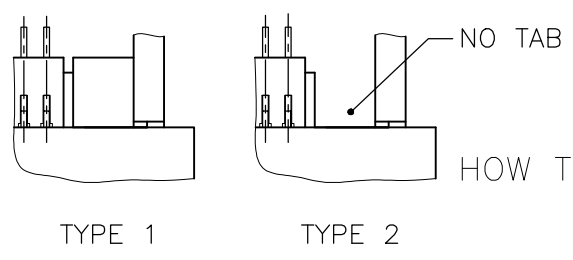
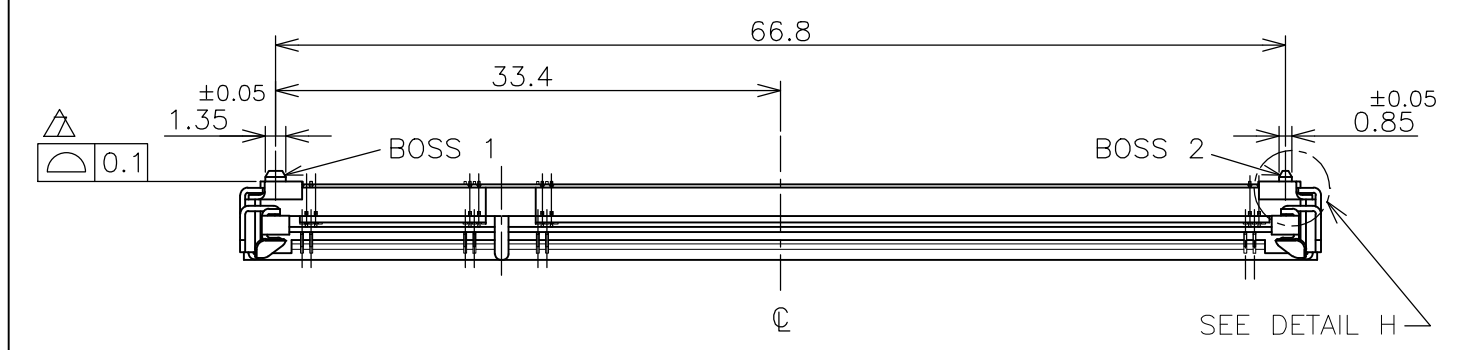
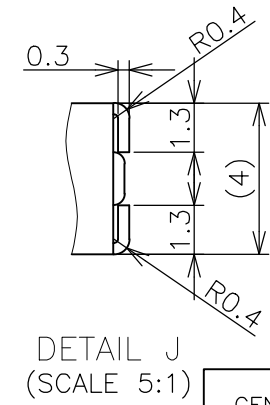
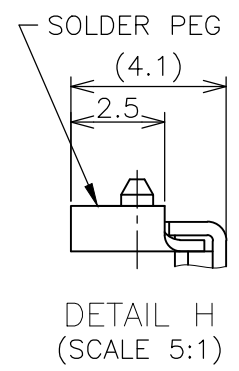
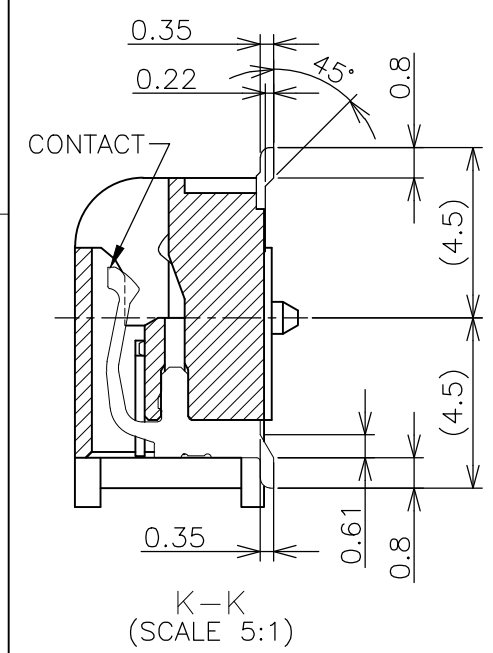

GENERAL TOLERANCE
 10 ≥ : ±0.2
 30 ≥ > 10 : ±0.25
 100 ≥ > 30 : ±0.3
 ANGLES : ±3°

TYPE 1	△	AVAILABLE	—H—	2.5V (DDR1)	18.45	1.5	1.8	200	1473005-5
TYPE 2	△	AVAILABLE	BOSSLESS	1.8V (DDR2)	17.55	2.4	2.7	200	1-1473005-4
TYPE 2	△	AVAILABLE	—H—	1.8V (DDR2)	17.55	2.4	2.7	200	1473005-4
TYPE 1	△	AVAILABLE	HOUSING COLOR:GRAY BOSSLESS	2.5V (DDR1)	18.45	1.5	1.8	200	6-1473005-1
TYPE 1	△	AVAILABLE	BOSSLESS	2.5V (DDR1)	18.45	1.5	1.8	200	1-1473005-1
TYPE 1	△	AVAILABLE	—H—	2.5V (DDR1)	18.45	1.5	1.8	200	1473005-1
TAB TYPE	FINISH	TOOLING STATUS	REMARK	POWER SUPPLY (TYPE)	D5	D4	D3	POS	PART NO.

THIS DRAWING IS A CONTROLLED DOCUMENT.

DWN	B.WONG	15JUL10	 TE Connectivity
CHK	C.WANG	15JUL10	
APVD	S.YAO	15JUL10	
PRODUCT SPEC	NAME		
APPLICATION SPEC	108-5701		DDR1 & DDR2 SODIMM SOCKET 0.6mm PITCH 200POS STANDARD PROFILE STANDARD TYPE
WEIGHT	4.7g	A300779	C-1473005
CUSTOMER DRAWING			SCALE 2:1 SHEET 1 OF 4 REV J3

THIS DRAWING IS UNPUBLISHED. RELEASED FOR PUBLICATION NOV ,2001.
 © COPYRIGHT 2001 By - ALL RIGHTS RESERVED.

LOC	DIST	REVISIONS			
P	LTR	DESCRIPTION	DATE	DWN	APVD
J		SEE SHEET 1	-	-	-

REFERENCE P.C. BOARD PATTERN LAYOUT (CONNECTOR MOUNTING SIDE)

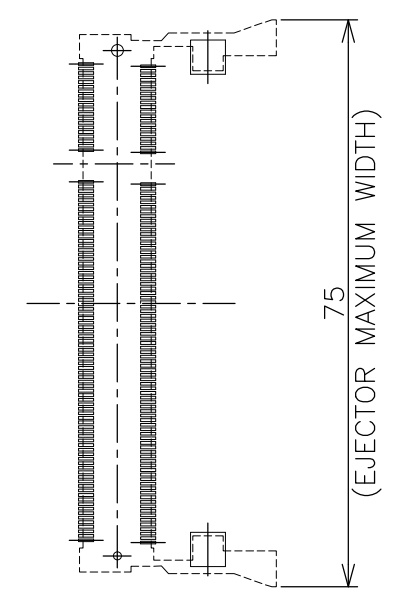

REAL SIZE (SCALE 1:1)

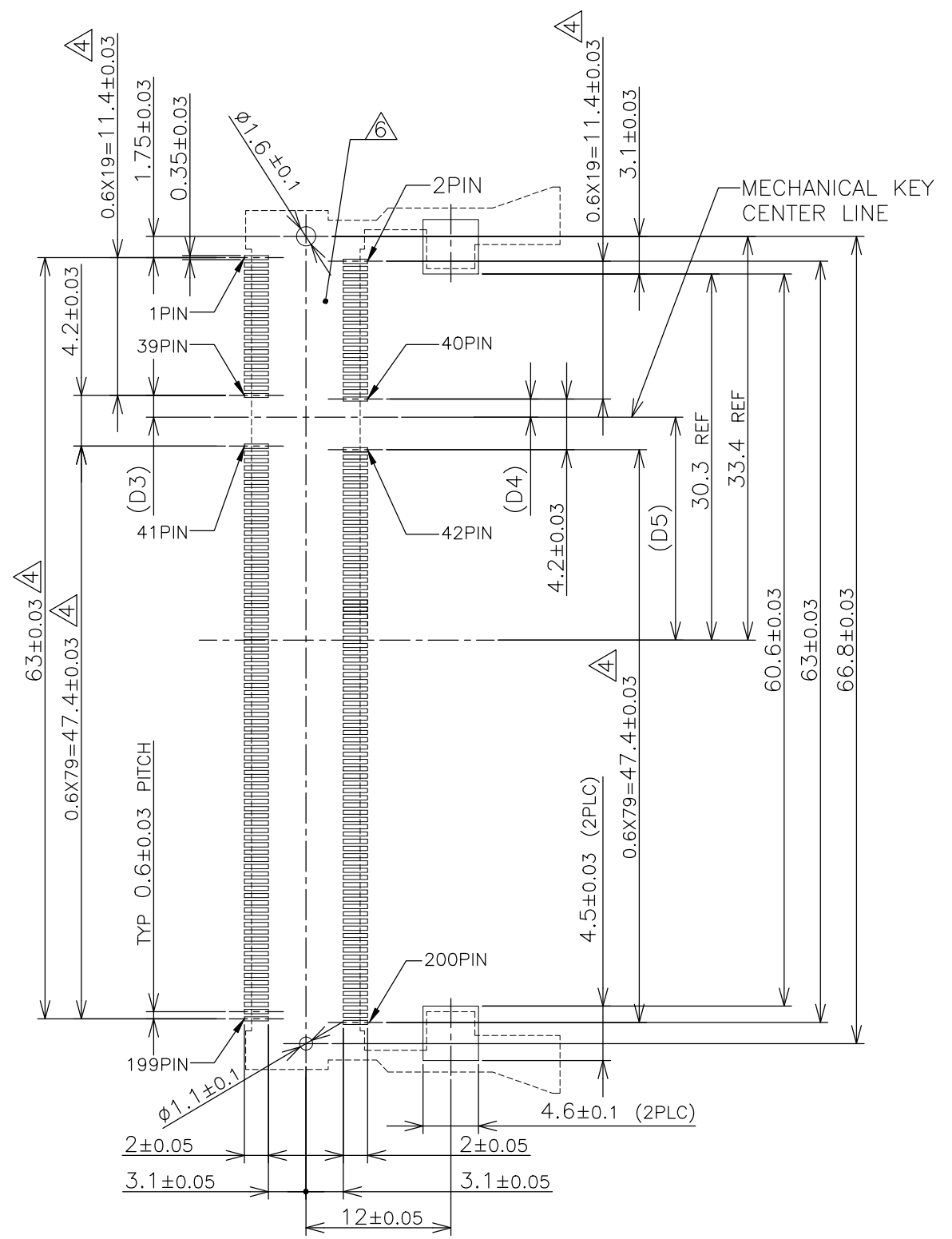

1.8V	17.55	2.4	2.7
2.5V	18.45	1.5	1.8
POWER SUPPLY	D5	D4	D3

THIS DRAWING IS A CONTROLLED DOCUMENT.		DWN	TE Connectivity NAME DDR1 & DDR2 SODIMM SOCKET 0.6mm PITCH 200POS STANDARD PROFILE STANDARD TYPE				
DIMENSIONS: MM		CHK					
TOLERANCES UNLESS OTHERWISE SPECIFIED:		APVD					
0 PLC ± 1 PLC ± 2 PLC ± 3 PLC ± 4 PLC ± ANGLES ± MATERIAL FINISH ±		PRODUCT SPEC					
MATERIAL		APVD	SIZE	CAGE CODE	DRAWING NO	RESTRICTED TO	
		APVD	A3	00779	C-1473005	-	
		APVD	CUSTOMER DRAWING		SCALE	SHEET	REV
		APVD			2:1	2 OF 4	J3

THIS DRAWING IS UNPUBLISHED. RELEASED FOR PUBLICATION NOV ,2001.
 © COPYRIGHT 2001 By - ALL RIGHTS RESERVED.

LOC	DIST	REVISIONS			
P	LTR	DESCRIPTION	DATE	DWN	APVD
J		SEE SHEET 1	-	-	-

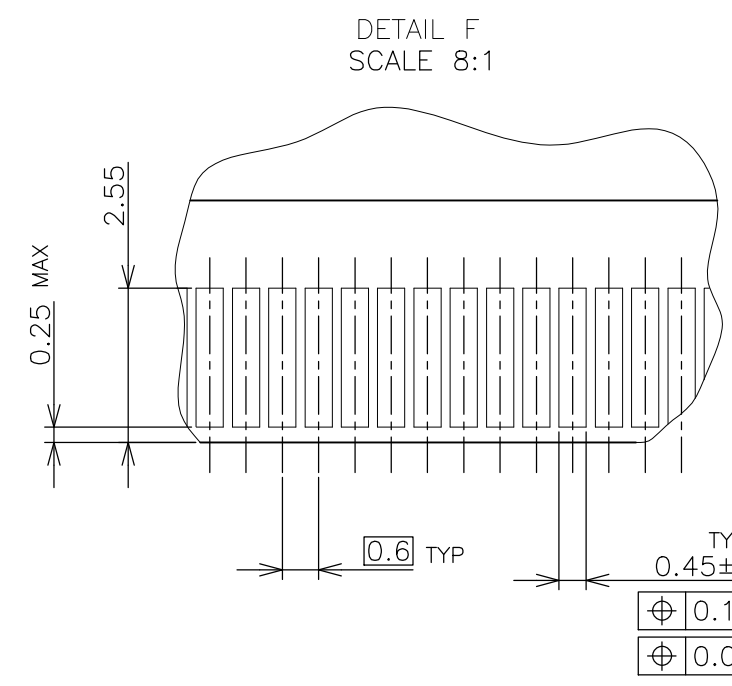
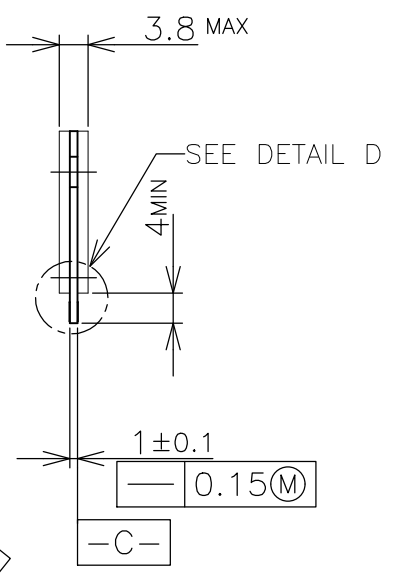
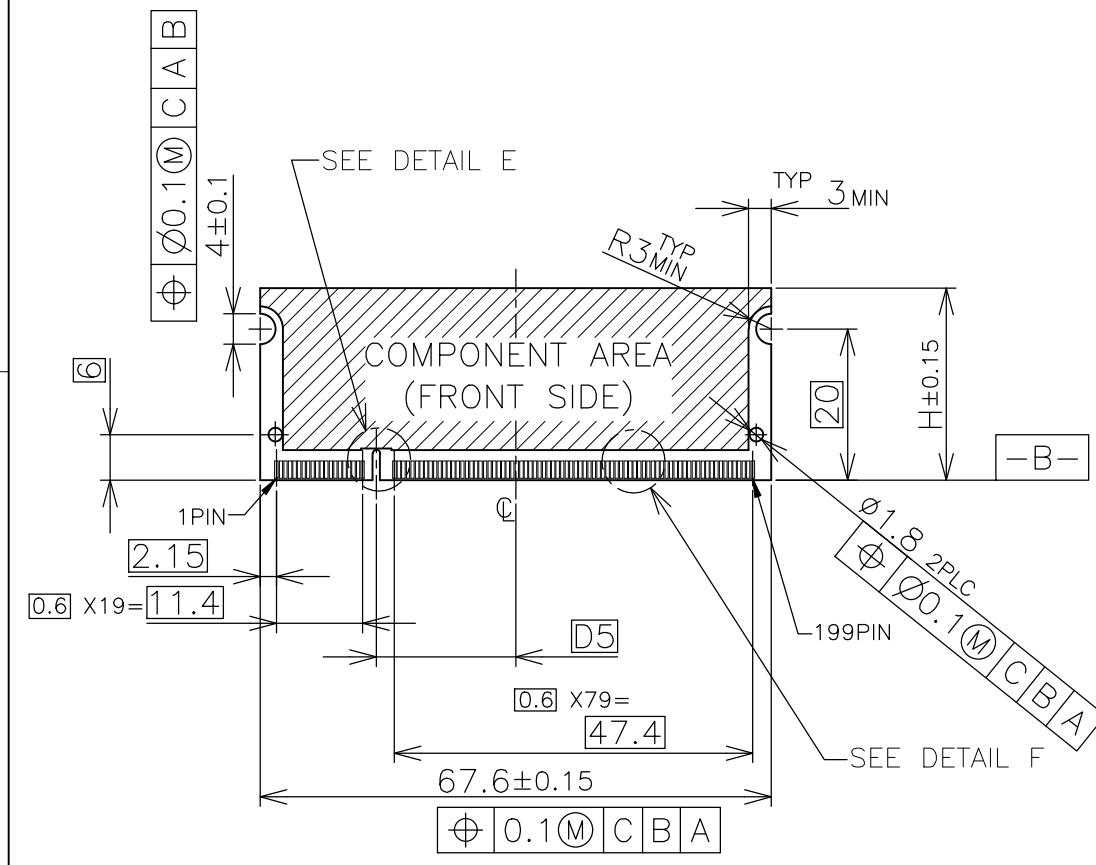

- (APPLIED TO SHEET 3)
1. TOLERANCES ON ALL DIMENSIONS ±0.15 UNLESS OTHERWISE SPECIFIED.
 2. P.C. BOARD THICKNESS APPLIES ACROSS TABS AND INCLUDES PLATING AND/OR METALIZATION.
 3. FINISH OF PAD : GOLD PLATING 0.00076 MIN. OVER Ni PLATING 0.002MIN.
- △ NO BURR
 ▽ CHAMFER 0.25 MAX x 45° IF EXIST.

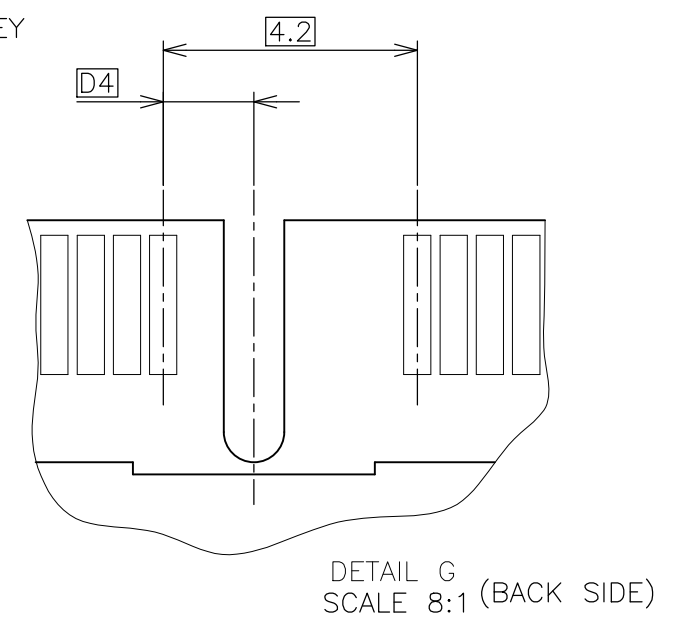
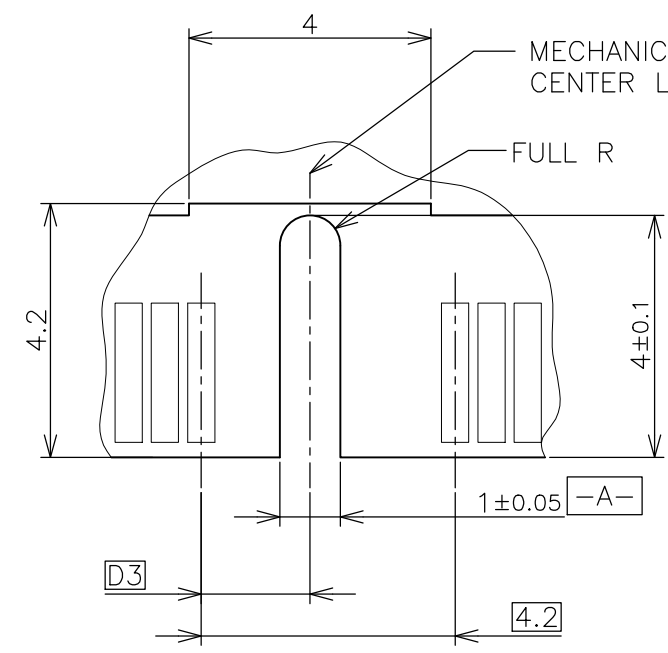
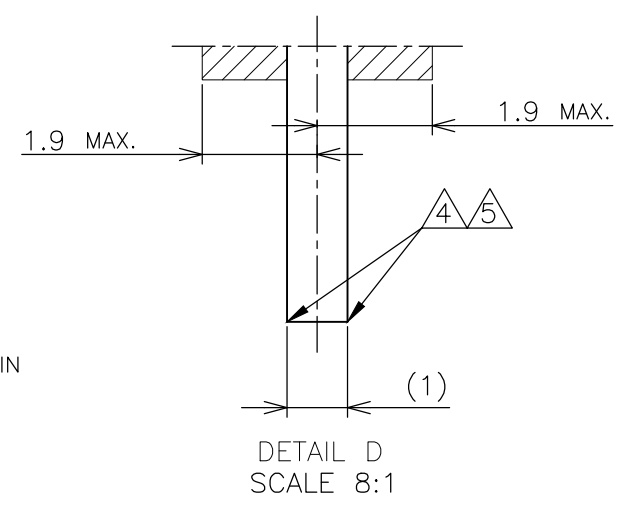
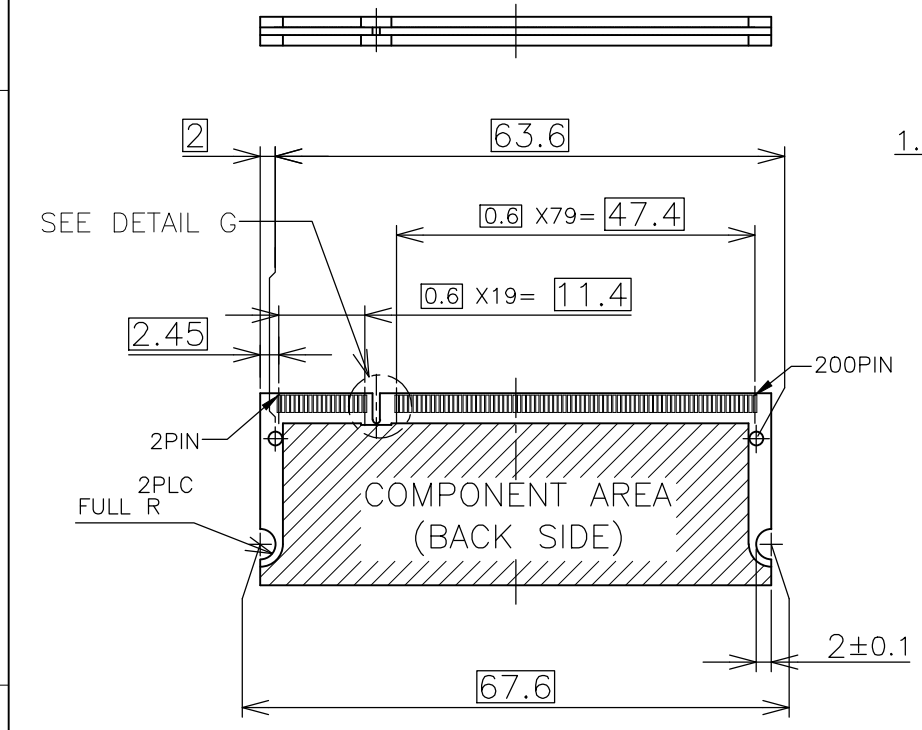

RECOMMENDED MATING P.C.B CONFIGURATION

THIS DRAWING IS A CONTROLLED DOCUMENT.		DWN
DIMENSIONS: MM		CHK
TOLERANCES UNLESS OTHERWISE SPECIFIED:		APVD
0 PLC ±		PRODUCT SPEC
1 PLC ±		APPLICATION SPEC
2 PLC ±		WEIGHT
3 PLC ±		CUSTOMER DRAWING
4 PLC ±		
ANGLES ±		
FINISH ±		
MATERIAL		

31.75	1.8V	17.55	2.4	2.7
25.4	2.5V	18.45	1.5	1.8
H	POWER SUPPLY	D5	D4	D3

STE TE Connectivity

NAME: DDR1 & DDR2 SODIMM SOCKET
 0.6mm PITCH 200POS
 STANDARD PROFILE STANDARD TYPE

SIZE	CAGE CODE	DRAWING NO	RESTRICTED TO
A3	00779	C-1473005	-

SCALE: 2:1 SHEET: 3 OF 4 REV: J3

THIS DRAWING IS UNPUBLISHED. RELEASED FOR PUBLICATION NOV , 2001.
 © COPYRIGHT 2001 By - ALL RIGHTS RESERVED.

LOC	DIST	REVISIONS			
P	LTR	DESCRIPTION	DATE	DWN	APVD
J		SEE SHEET 1	-	-	-

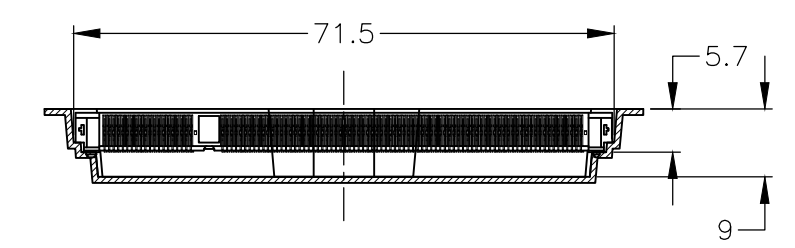
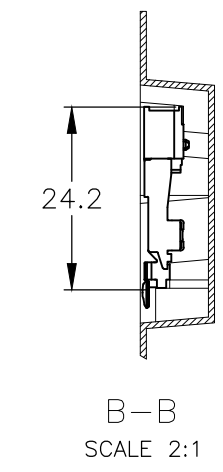
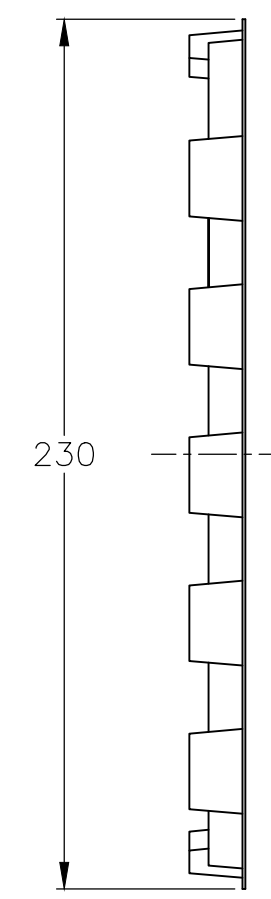
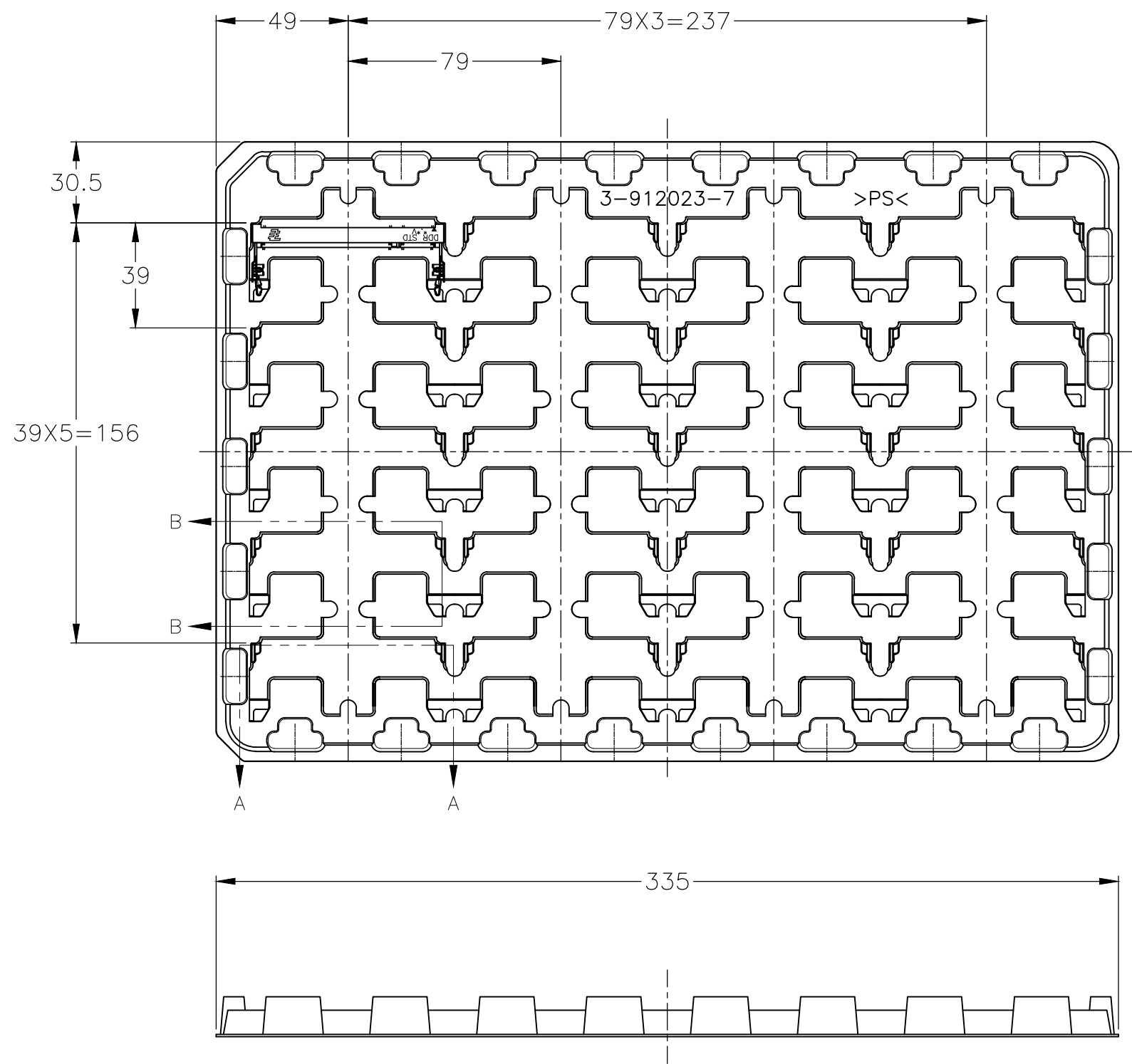

2.5V (DDR1)	20EA/TRAY	1473005-5
1.8V (DDR2)	20EA/TRAY	1-1473005-4
1.8V (DDR2)	20EA/TRAY	1473005-4
2.5V (DDR1)	20EA/TRAY	6-1473005-1
2.5V (DDR1)	20EA/TRAY	1-1473005-1
2.5V (DDR1)	20EA/TRAY	1473005-1
POWER SUPPLY (TYPE)	QTY	P/N

(APPLIED TO SHEET 4)
 1. THE DIRECTION OF EACH CONNECTOR ON A TRAY IS REFERRED TO THIS DRAWING.
 2. GENERAL TOLERANCE: ±0.5

THIS DRAWING IS A CONTROLLED DOCUMENT.		DWN	TE Connectivity NAME DDR1 & DDR2 SODIMM SOCKET 0.6mm PITCH 200POS STANDARD PROFILE STANDARD TYPE					
DIMENSIONS: MM		CHK				SIZE	CAGE CODE	DRAWING NO
TOLERANCES UNLESS OTHERWISE SPECIFIED: 0 PLC ± 1 PLC ± 2 PLC ± 3 PLC ± 4 PLC ± ANGLES ± FINISH ±		APVD				A300779 C-1473005		
MATERIAL		PRODUCT SPEC				RESTRICTED TO		
		APPLICATION SPEC	CUSTOMER DRAWING					
		WEIGHT	SCALE 1:2 SHEET 4 OF 4 REV J3					