

2W isolated DC-DC converter  
Fixed input voltage, unregulated dual/ single output

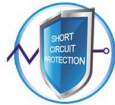
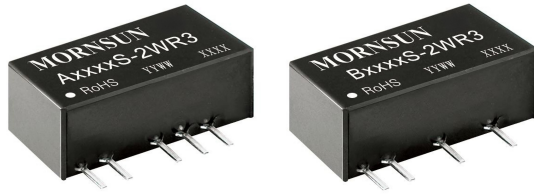

Continuous Short  
Circuit Protection

CE Report EN 62368-1    UKCA Report BS EN 62368-1    CB RoHS IEC 62368-1    Patent Protection

### FEATURES

- Continuous short-circuit protection
- No-load input current as low as 8mA
- Operating ambient temperature range: -40°C to +105°C
- High efficiency up to 86%
- High power density
- I/O isolation test voltage 1.5k VDC
- Industry standard pin-out

A\_S-2WR3 & B\_S-2WR3 series are specially designed for applications where an (two) isolated voltage is required in a distributed power supply system. They are suitable for:

1. The voltage of the input power supply is relatively stable with a variation of  $\pm 10\%V_{in}$  or less;
2. An input to output isolation voltage of up to 1500VDC is necessary;
3. The requirement for a tight output regulation is not as strict.

### Selection Guide

Certification	Part No.	Input Voltage (VDC)	Output		Full Load Efficiency (%) Min./Typ.	Capacitive Load*( $\mu$ F) Max.
		Nominal (Range)	Voltage (VDC)	Current (mA) Max./Min.		
-	A0503S-2WR3	5 (4.5-5.5)	$\pm 3.3$	$\pm 303/\pm 30$	71/75	1200
	A0505S-2WR3		$\pm 5$	$\pm 200/\pm 20$	80/84	1200
	A0509S-2WR3		$\pm 9$	$\pm 111/\pm 11$	81/85	470
	A0512S-2WR3		$\pm 12$	$\pm 83/\pm 8$	81/85	220
	A0515S-2WR3		$\pm 15$	$\pm 67/\pm 7$	82/86	220
	A0524S-2WR3		$\pm 24$	$\pm 42/\pm 4$	82/86	100
	B0503S-2WR3		3.3	400/40	74/78	2400
	B0505S-2WR3		5	400/40	80/84	2400
	B0507S-2WR3		7.2	278/28	80/84	1000
	B0509S-2WR3		9	222/22	81/85	1000
	B0512S-2WR3		12	167/17	81/85	560
	B0515S-2WR3		15	133/13	82/86	560
	B0524S-2WR3		24	83/8	82/86	220
EN/BS EN/IEC	A1203S-2WR3	12 (10.8-13.2)	$\pm 3.3$	$\pm 303/\pm 30$	71/75	1200
	A1205S-2WR3		$\pm 5$	$\pm 200/\pm 20$	76/80	1200
-	A1207S-2WR3		$\pm 7.2$	$\pm 139/\pm 13$	76/80	470
	A1209S-2WR3		$\pm 9$	$\pm 111/\pm 11$	78/82	470
EN/BS EN/IEC	A1212S-2WR3		$\pm 12$	$\pm 83/\pm 8$	79/83	220
	A1215S-2WR3		$\pm 15$	$\pm 67/\pm 7$	79/83	220
-	A1224S-2WR3		$\pm 24$	$\pm 42/\pm 4$	79/83	100
-	B1203S-2WR3		3.3	400/40	75/79	2400
EN/BS EN/IEC	B1205S-2WR3		5	400/40	78/82	2400
-	B1209S-2WR3		9	222/22	78/82	1000
EN/BS EN/IEC	B1212S-2WR3		12	167/17	80/84	560
	B1215S-2WR3		15	133/13	81/85	560
	B1224S-2WR3		24	83/8	82/86	220

--	A1505S-2WR3	15 (13.5-16.5)	±5	±200/±20	76/80	1200
	A1515S-2WR3		±15	±67/±7	78/82	220
	B1505S-2WR3		5	400/40	76/80	2400
	B1515S-2WR3		15	133/13	77/81	560
	B1524S-2WR3		24	83/8	77/81	220
	A2403S-2WR3		±3.3	±303/±30	70/76	1200
EN/BS EN/IEC	A2405S-2WR3	24 (21.6-26.4)	±5	±200/±20	74/80	1200
--	A2407S-2WR3		±7.2	±139/±13	74/80	470
	A2409S-2WR3		±9	±111/±11	75/81	470
EN/BS EN/IEC	A2412S-2WR3		±12	±83/±8	77/83	220
	A2415S-2WR3		±15	±67/±7	77/83	220
--	A2424S-2WR3		±24	±42/±4	77/83	100
	B2403S-2WR3	3.3	400/40	70/76	2400	
EN/BS EN/IEC	B2405S-2WR3	24 (21.6-26.4)	5	400/40	74/80	2400
--	B2409S-2WR3		9	222/22	75/81	1000
	B2412S-2WR3		12	167/17	78/84	560
EN/BS EN/IEC	B2415S-2WR3		15	133/13	80/86	560
	B2424S-2WR3		24	83/8	80/86	220

Note: \* The specified maximum capacitive load for positive and negative output is identical.

### Input Specifications

Item	Operating Conditions	Min.	Typ.	Max.	Unit	
Input Current (full load / no-load)	5VDC input	3.3VDC output	--	534/8	564/--	mA
		5VDC/7.2VDC output	--	477/8	500/--	
		9VDC/12VDC output	--	471/8	494/--	
		15VDC/24VDC output	--	466/8	488/--	
	12VDC input	3.3VDC output	--	223/8	235/--	
		5VDC/7.2VDC output	--	208/8	219/--	
		9VDC output	--	203/8	214/--	
		12VDC/15VDC/24VDC output	--	201/8	211/--	
	15VDC input	5VDC output	--	167/8	176/--	
		15VDC output	--	163/8	171/--	
		24VDC output	--	165/8	174/--	
	24VDC input	3.3VDC output	--	110/8	120/--	
5VDC/7.2VDC output		--	104/8	112/--		
9VDC output		--	103/8	111/--		
12VDC/15VDC/24VDC output		--	101/8	108/--		
Reflected Ripple Current*		--	15	--		
Surge Voltage (1sec. max.)	5VDC input	-0.7	--	9	VDC	
	12VDC input	-0.7	--	18		
	15VDC input	-0.7	--	21		
	24VDC input	-0.7	--	30		
Input Filter		Capacitance filter				
Hot Plug		Unavailable				

Note: \* Refer to DC-DC Converter Application Notes for detailed description of reflected ripple current test method.

### Output Specifications

Item	Operating Conditions		Min.	Typ.	Max.	Unit	
Voltage Accuracy			See output regulation curve(Fig. 1)				
Linear Regulation	Input voltage change: ±1%	3.3VDC output	--	--	±1.5	--	
		Others	--	--	±1.2		
Load Regulation	5VDC input	3.3VDC output	--	10	20	%	
		5VDC/7.2VDC output	--	8	15		
		9VDC/12VDC/15VDC output	--	7	10		
		24VDC output	--	5	10		
	10%-100% load	12/15/24 VDC input	3.3VDC output	--	15		20
			5VDC output	--	7		15
			7.2VDC output	--	6		15
			9VDC output	--	5		15
			12VDC output	--	5		10
			15VDC output	--	4		10
Ripple & Noise*	20MHz bandwidth	5VDC input	--	75	200	mVp-p	
		12/15/24VDC input	--	75	180		
Temperature Coefficient	Full load		--	±0.02	--	%/°C	
Short-circuit Protection			Continuous, self-recovery				

Note: \* The "parallel cable" method is used for Ripple and Noise test, please refer to DC-DC Converter Application Notes for specific information.

### General Specifications

Item	Operating Conditions		Min.	Typ.	Max.	Unit
Isolation	Input-output electric strength test for 1 minute with a leakage current of 1mA max.		1500	--	--	VDC
Insulation Resistance	Input-output resistance at 500VDC		1000	--	--	MΩ
Isolation Capacitance	Input-output capacitance at 100kHz/0.1V		--	20	--	pF
Operating Temperature	Derating when operating temperature ≥ 85°C, (see Fig. 2)		-40	--	105	°C
Storage Temperature			-55	--	125	
Case Temperature Rise	Ta=25°C	5VDC input	--	25	--	
		12/15/24VDC input	--	15	--	
Pin Soldering Resistance Temperature	Soldering spot is 1.5mm away from case for 10 seconds		--	--	300	
Storage Humidity	Non-condensing		5	--	95	%RH
Vibration			10-150Hz, 5G, 0.75mm. along X, Y and Z			
Switching Frequency	Full load, nominal input voltage	5VDC input	--	220	--	kHz
		12/15/24VDC input	--	260	--	
MTBF	MIL-HDBK-217F @ 25°C		3500	--	--	k hours

### Mechanical Specifications

Case Material	Black plastic; flame-retardant and heat-resistant (UL94V-0)
Dimensions	19.65 x 7.05 x 10.16mm
Weight	2.4g(Typ.)
Cooling Method	Free air convection

### Electromagnetic Compatibility (EMC)

Emissions	CE	CISPR32/EN55032 CLASS B
	RE	CISPR32/EN55032 CLASS B
Immunity	ESD	IEC/EN61000-4-2 Air ±8kV, Contact ±6kV perf. Criteria B

Note: Refer to Fig. 4 for recommended circuit test

Typical Characteristic Curves

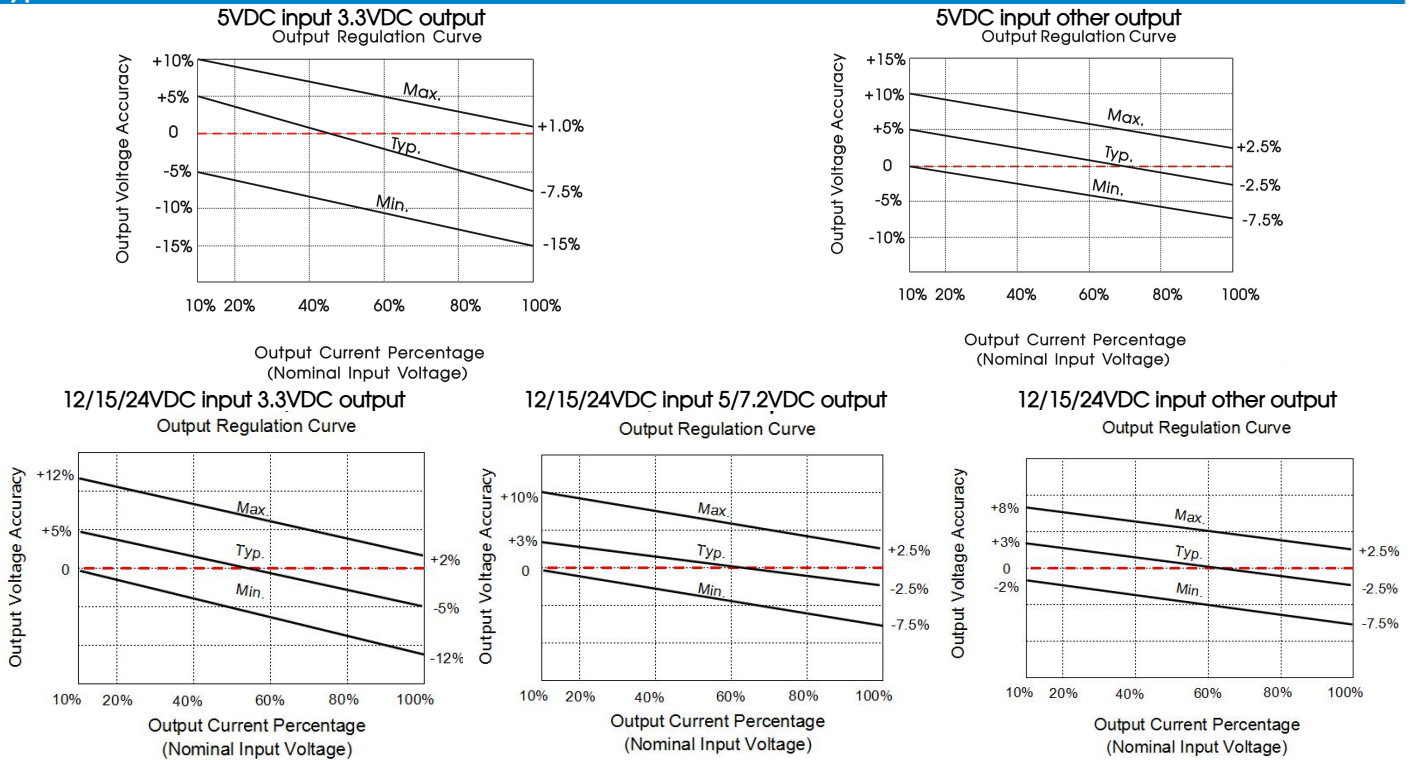

Fig. 1

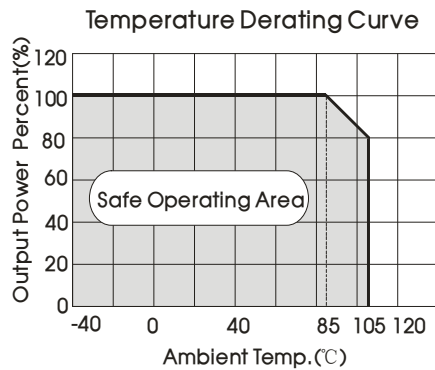
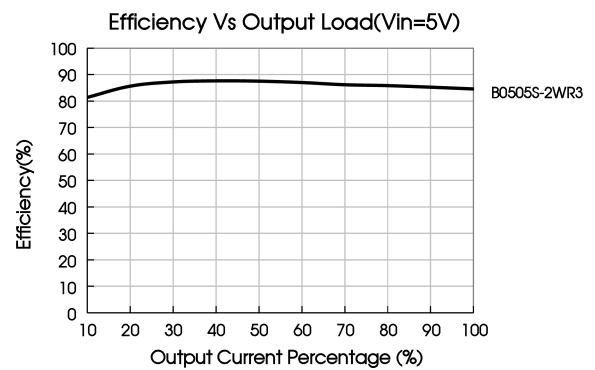
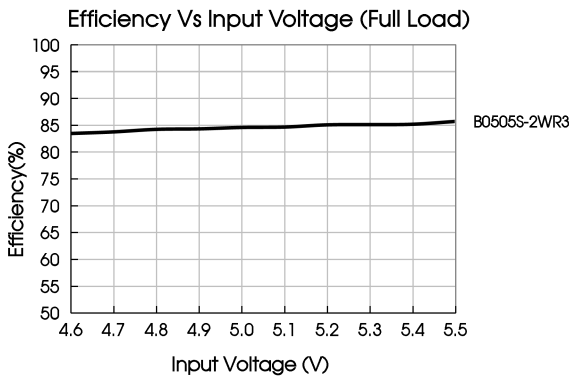

Fig. 2



Design Reference

1. Typical application

Input and/or output ripple can be further reduced, by connecting a filter capacitor from the input and/or output terminals to ground as shown in Fig. 3.

Choosing suitable filter capacitor values is very important for a smooth operation of the modules, particularly to avoid start-up problem caused by capacitor values that are too high. For recommended input and output capacitor values refer to Table 1.

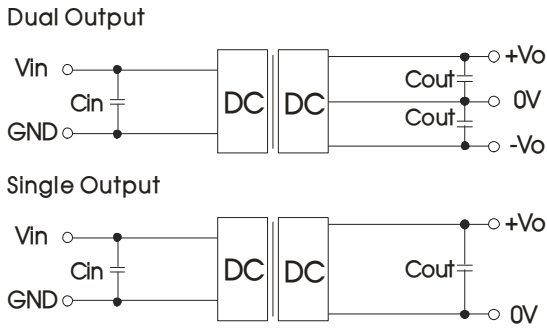

Fig. 3

Table 1: Recommended input and output capacitor values

Vin	Cin	Single Vout	Cout	Dual Vout	Cout'
5VDC	10μF/16V	3.3VDC	10μF/16V	±3.3VDC	4.7μF/16V
12VDC	2.2μF/25V	5VDC	10μF/16V	±5VDC	4.7μF/16V
15VDC	2.2μF/25V	7.2VDC	10μF/16V	±7.2VDC	2.2μF/25V
24VDC	1μF/50V	9VDC	2.2μF/25V	±9VDC	2.2μF/25V
--	--	12VDC	2.2μF/25V	±12VDC	1μF/25V
--	--	15VDC	1μF/25V	±15VDC	1μF/25V
--	--	24VDC	1μF/50V	±24VDC	0.47μF/50V

Note: The capacitor value of the positive and the negative output is identical.

2. EMC compliance circuit

Single Output

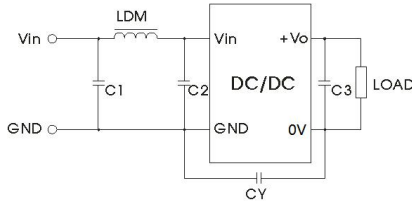

Dual Output

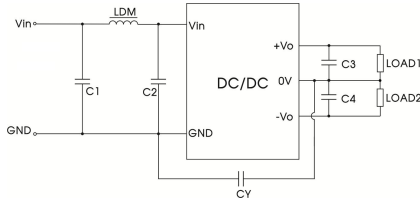

Fig. 4

Input voltage		5 VDC	12/15/24 VDC
Emissions	C1/C2	4.7μF /16V	4.7μF /50V
	CY	270pF/2kV	
	C3	Refer to Cout in Fig. 3	
	LDM	6.8μH	

Input voltage		5 VDC	12/15/24 VDC
Emissions	C1/C2	4.7μF /16V	4.7μF /50V
	CY	270pF/2kV	
	C3/C4	Refer to Cout in Fig. 3	
	LDM	6.8μH	

3. For additional information please refer to DC-DC converter application notes on [www.mornsun-power.com](http://www.mornsun-power.com)

Dimensions and Recommended Layout

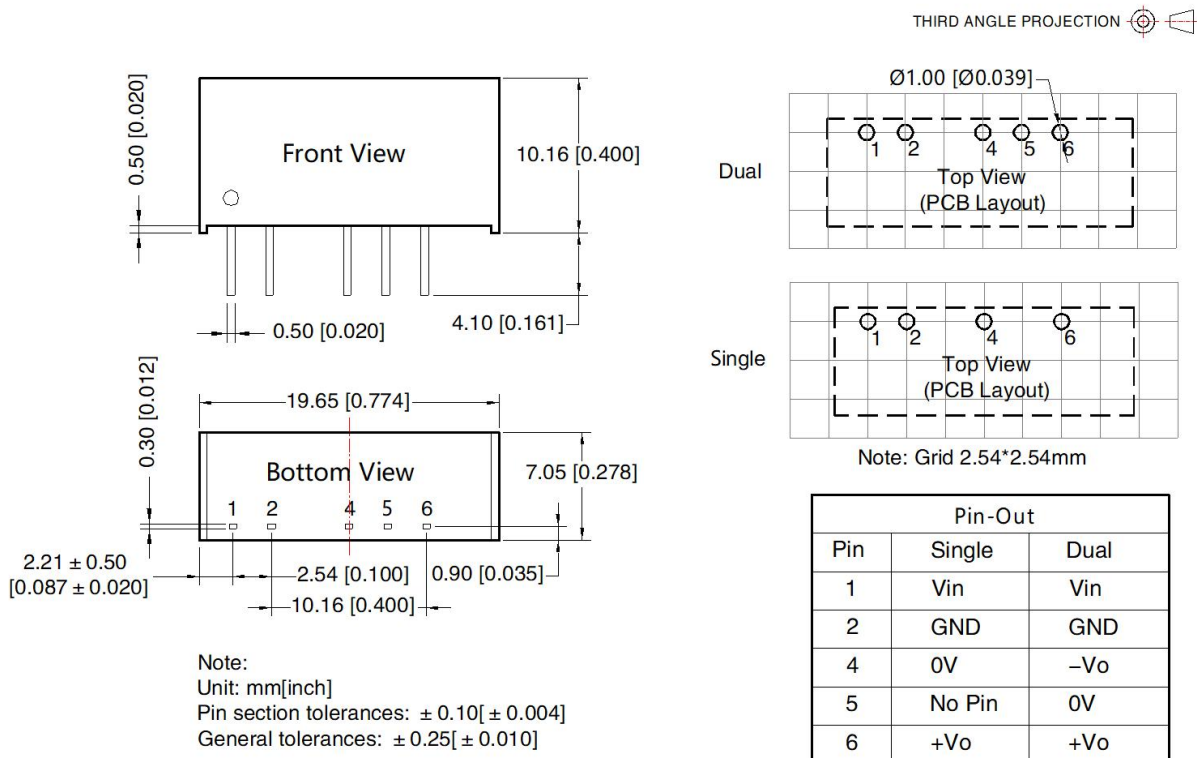

Notes:

1. For additional information on Product Packaging please refer to [www.mornsun-power.com](http://www.mornsun-power.com). Packaging bag number: 58200001;
2. If the product is not operated within the required load range, the product performance cannot be guaranteed to comply with all parameters in the datasheet;
3. The maximum capacitive load offered were tested at input voltage range and full load;
4. Unless otherwise specified, parameters in this datasheet were measured under the conditions of  $T_a=25^{\circ}\text{C}$ , humidity<75%RH with nominal input voltage and rated output load;
5. All index testing methods in this datasheet are based on our company corporate standards;
6. We can provide product customization service, please contact our technicians directly for specific information;
7. Products are related to laws and regulations: see "Features" and "EMC";
8. Our products shall be classified according to ISO14001 and related environmental laws and regulations, and shall be handled by qualified units.

MORNSUN Guangzhou Science & Technology Co., Ltd.

Address: No. 8 Nanyun 4th Road, Huangpu District, Guangzhou, China

Tel: 86-20-38601850

Fax: 86-20-38601272

E-mail: [info@mornsun.cn](mailto:info@mornsun.cn)

[www.mornsun-power.com](http://www.mornsun-power.com)