

3-TERMINAL 0.1A POSITIVE VOLTAGE REGULATORS

DESCRIPTION

The 78LXX series of fixed voltage monolithic integrated circuit voltage regulators are suitable for applications that required supply up to 100mA.

FEATURE

- *Maximum output current of 100mA
- *Output voltage of 5V,6V,8V,9V,10V,12V,15V and 24V
- *Thermal overload protection
- *Short circuit current limiting

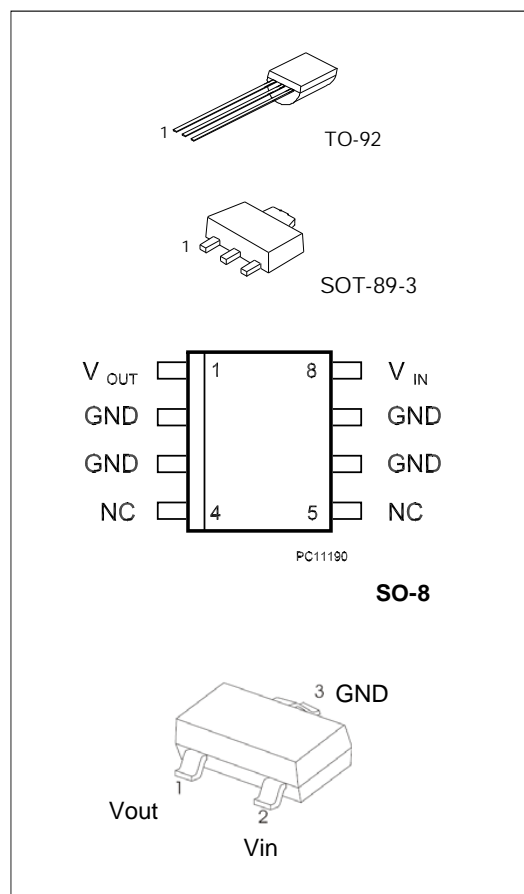

BLOCK DIAGRAM

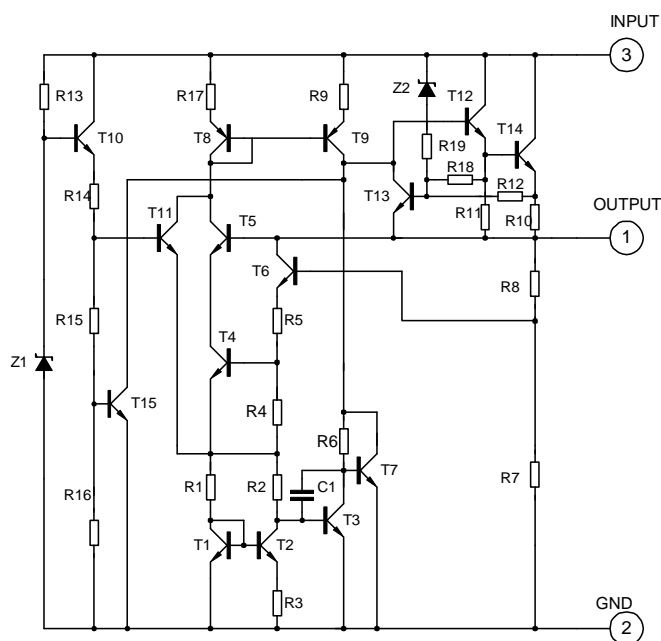

ABSOLUTE MAXIMUM RATINGS (Operating temperature range applies unless otherwise specified)

CHARACTERISTICS	SYMBOL	VALUE	UNITS
Input voltage(for $V_o=5,8V$) (for $V_o=12,15V$)	V_i	30	V
	V_i	35	V
High power dissipation	P_d	TO-92	700
		SOT-23	300
		SOT-89	400
		SOP-8	400
Operating Junction Temperature Range	T_{opr}	-20~+120	°C
Storage Temperature Range	T_{stg}	-55~+150	°C

78L05 ELECTRICAL CHARACTERISTICS

 ($V_i=10V, I_o=40mA, 0 < T_j < 125^\circ C, C_1=0.33\mu F, C_o=0.1\mu F$, unless otherwise specified)(Note 1)

Characteristic	Symbol	Test conditions	MIN	TYP	MAX	UNIT
Output Voltage	V_o	$T_j=25^\circ C$	4.8	5.0	5.2	V
		$7.5V \leq V_i \leq 20V, I_o=1mA \sim 40mA$	4.75		5.25	V
		$7.5V \leq V_i \leq V_{MAX}, I_o=1mA \sim 70mA$	4.75		5.25	V (note 2)
Output Voltage(note 3)	V_o	$T_j=25^\circ C$	4.9	5.0	5.1	V
		$7.5V \leq V_i \leq 20V, I_o=1mA \sim 40mA$	4.85		5.15	V
		$7.5V \leq V_i \leq V_{MAX}, I_o=1mA \sim 70mA$	4.85		5.15	V (note 2)
Load Regulation	ΔV_o	$T_j=25^\circ C, I_o=1mA \sim 100mA$		11	60	mV
		$T_j=25^\circ C, I_o=1mA \sim 40mA$		5.0	30	mV
Line regulation	ΔV_o	$7V \leq V_i \leq 20V, T_j=25^\circ C$		8	150	mV
		$8V \leq V_i \leq 20V, T_j=25^\circ C$		6	100	mV
Quiescent Current	I_q			2.0	5.5	mA
Quiescent Current Change	ΔI_q	$8V \leq V_i \leq 20V$			1.5	mA
	ΔI_q	$1mA \leq V_i \leq 40mA$			0.1	mA
Output Noise Voltage	V_N	$10Hz \leq f \leq 100kHz$		40		μV
Temperature coefficient of V_o	$\Delta V_o / \Delta T$	$I_o=5mA$		0.65		$mV/^\circ C$
Ripple Rejection	RR	$8V \leq V_i \leq 20V, f=120Hz, T_j=25^\circ C$	40	49		dB
Dropout Voltage	V_d	$T_j=25^\circ C$		1.7		V

78L06 ELECTRICAL CHARACTERISTICS

($V_I=12V, I_O=40mA, 0 < T_J < 125^\circ C, C_1=0.33\mu F, C_o=0.1\mu F$, unless otherwise specified)(Note 1)

Characteristic	Symbol	Test conditions	MIN	TYP	MAX	UNIT
Output Voltage	Vo	Tj=25°C	5.75	6.0	6.25	V
		8.5V≤Vi≤20V, Io=1mA~40mA	5.7		6.3	V
		8.5V≤Vi≤VMAX, Io=1mA~70mA	5.7		6.3	V (note 2)
Output Voltage(note 3)	Vo	Tj=25°C	5.88	6.0	6.12	V
		8.5V≤Vi≤20V, Io=1mA~40mA	5.82		6.18	V
		8.5V≤Vi≤VMAX, Io=1mA~70mA	5.82		6.18	V (note 2)
Load Regulation	ΔVo	Tj=25°C, Io=1mA~100mA		12.8	80	mV
		Tj=25°C, Io=1mA~70mA		5.8	40	mV
Line regulation	ΔVo	8.5V≤Vi≤20V, Tj=25°C		64	175	mV
		9V≤Vi≤20V, Tj=25°C		54	125	mV
Quiescent Current	Iq			2.0	5.5	mA
Quiescent Current Change	ΔIq	9V≤Vi≤20V			1.5	mA
	ΔIq	1mA≤Io≤40mA			0.1	mA
Output Noise Voltage	VN	10Hz≤f≤100kHz		49		μV
Temperature coefficient of Vo	ΔVo/ΔT	Io=5mA		0.75		mV/°C
Ripple Rejection	RR	10V≤Vi≤20V, f=120Hz, Tj=25°C	38	46		dB
Dropout Voltage	Vd	Tj=25°C		1.7		V

78L08 ELECTRICAL CHARACTERISTICS

($V_I=14V, I_o=40mA, 0 < T_j < 125^\circ C, C_1=0.33\mu F, C_o=0.1\mu F$, unless otherwise specified)(Note 1)

Characteristic	Symbol	Test conditions	MIN	TYP	MAX	UNIT
Output Voltage	Vo	Tj=25°C	7.7	8.0	8.3	V
		10.5V ≤ Vi ≤ 23V, Io=1mA~40mA	7.6		8.4	V
		10.5V ≤ Vi ≤ VMAX, Io=1mA~70mA	7.6		8.4	V (note 2)
Output Voltage(note 3)	Vo	Tj=25°C	7.84	8.0	8.16	V
		10.5V ≤ Vi ≤ 23V, Io=1mA~40mA	7.76		8.24	V
		10.5V ≤ Vi ≤ VMAX, Io=1mA~70mA	7.76		8.24	V (note 2)
Load Regulation	ΔVo	Tj=25°C, Io=1mA~100mA		15	80	mV
		Tj=25°C, Io=1mA~70mA		8.0	40	mV
Line regulation	ΔVo	10.5V ≤ Vi ≤ 23V, Tj=25°C		10	175	mV
		11V ≤ Vi ≤ 23V, Tj=25°C		8	125	mV
Quiescent Current	Iq			2.0	5.5	mA
Quiescent Current Change	ΔIq	11V ≤ Vi ≤ 23V			1.5	mA
	ΔIq	1mA ≤ Vi ≤ 40mA			0.1	mA
Output Noise Voltage	VN	10Hz ≤ f ≤ 100kHz		49		μV
Temperature coefficient of Vo	ΔVo/ΔT	Io=5mA		0.75		mV/°C
Ripple Rejection	RR	11V ≤ Vi ≤ 23V, f=120Hz, Tj=25°C	36	45		dB
Dropout Voltage	Vd	Tj=25°C		1.7		V

78L09 ELECTRICAL CHARACTERISTICS

($V_I=15V, I_O=40mA, 0 < T_j < 125^\circ C, C_1=0.33\mu F, C_o=0.1\mu F$, unless otherwise specified)(Note 1)

Characteristic	Symbol	Test conditions	MIN	TYP	MAX	UNIT
Output Voltage	Vo	Tj=25°C	8.64	9.0	9.36	V
		11.5V ≤ Vi ≤ 24V, Io=1mA~40mA	8.55		9.45	V
		11.5V ≤ Vi ≤ VMAX, Io=1mA~70mA	8.55		9.45	V (note 2)
Output Voltage(note 3)	Vo	Tj=25°C	8.82	9.0	9.18	V
		11.5V ≤ Vi ≤ 24V, Io=1mA~40mA	8.73		9.27	V
		11.5V ≤ Vi ≤ VMAX, Io=1mA~70mA	8.73		9.27	V (note 2)
Load Regulation	ΔVo	Tj=25°C, Io=1mA~100mA		20	90	mV
		Tj=25°C, Io=1mA~40mA		10	45	mV
Line regulation	ΔVo	11.5V ≤ Vi ≤ 24V, Tj=25°C		90	200	mV
		13V ≤ Vi ≤ 24V, Tj=25°C		100	150	mV
Quiescent Current	Iq			2.0	5.5	mA
Quiescent Current Change	ΔIq	13V ≤ Vi ≤ 24V			1.5	mA
	ΔIq	1mA ≤ Vi ≤ 40mA			0.1	mA
Output Noise Voltage	VN	10Hz ≤ f ≤ 100kHz		49		μV
Temperature coefficient of Vo	ΔVo/ΔT	Io=5mA		0.75		mV/°C
Ripple Rejection	RR	12V ≤ Vi ≤ 23V, f=120Hz, Tj=25°C	36	44		dB
Dropout Voltage	Vd	Tj=25°C		1.7		V

78L12 ELECTRICAL CHARACTERISTICS

(VI=19V, IO=40mA, 0<Tj<125°C, C1=0.33μF, Co=0.1μF, unless otherwise specified)(Note 1)

Characteristic	Symbol	Test conditions	MIN	TYP	MAX	UNIT
Output Voltage	Vo	Tj=25°C	11.5	12	12.6	V
		14.5V≤Vi≤27V, Io=1mA~40mA	11.4		12.6	V
		14.5V≤Vi≤VMAX, Io=1mA~70mA	11.4		12.6	V (note 2)
Output Voltage(note 3)	Vo	Tj=25°C	11.76	12.0	12.24	V
		14.5V≤Vi≤27V, Io=1mA~40mA	11.64		12.36	V
		14.5V≤Vi≤VMAX, Io=1mA~70mA	11.64		12.36	V (note 2)
Load Regulation	ΔVo	Tj=25°C, Io=1mA~100mA		25	150	mV
		Tj=25°C, Io=1mA~40mA		12	75	mV
Line regulation	ΔVo	14.5V≤Vi≤27V, Tj=25°C		25	300	mV
		16V≤Vi≤27V, Tj=25°C		20	250	mV
Quiescent Current	Iq			2.0	5.5	mA
Quiescent Current Change	ΔIq	16V≤Vi≤27V			1.5	mA
	ΔIq	1mA≤Vi≤40mA			0.1	mA
Output Noise Voltage	VN	10Hz≤f≤100kHz		80		μV
Temperature coefficient of Vo	ΔVo/ΔT	Io=5mA		1.0		mV/°C
Ripple Rejection	RR	15V≤Vi≤25V, f=120Hz, Tj=25°C	36	42		dB
Dropout Voltage	Vd	Tj=25°C		1.7		V

78L15 ELECTRICAL CHARACTERISTICS

(VI=23V, Io=40mA, 0<Tj<125°C, C1=0.33μF, Co=0.1μF, unless otherwise specified)(Note 1)

Characteristic	Symbol	Test conditions	MIN	TYP	MAX	UNIT
Output Voltage	Vo	Tj=25°C	14.4	15	15.6	V
		17.5V≤Vi≤30V, Io=1mA~40mA	14.25		15.75	V
		17.5V≤Vi≤VMAX, Io=1mA~70mA	14.25		15.75	V (note 2)
Output Voltage(note 3)	Vo	Tj=25°C	14.7	15.0	15.3	V
		17.5V≤Vi≤30V, Io=1mA~40mA	14.55		15.45	V
		17.5V≤Vi≤VMAX, Io=1mA~70mA	14.55		15.45	V (note 2)
Load Regulation	ΔVo	Tj=25°C, Io=1mA~100mA		20	150	mV
		Tj=25°C, Io=1mA~70mA		25	150	mV
Line regulation	ΔVo	17.5V≤Vi≤30V, Tj=25°C		25	150	mV
		20V≤Vi≤30V, Tj=25°C		15	75	mV
Quiescent Current	Iq			2.2	6.0	mA
Quiescent Current Change	ΔIq	20V≤Vi≤30V			1.5	mA
	ΔIq	1mA≤Vi≤40mA			0.1	mA
Output Noise Voltage	VN	10Hz≤f≤100kHz		90		μV
Temperature coefficient of Vo	ΔVo/ΔT	Io=5mA		1.3		mV/°C
Ripple Rejection	RR	18.5V≤Vi≤28.5V, f=120Hz, Tj=25°C	33	39		dB
Dropout Voltage	Vd	Tj=25°C		1.7		V

78L18 ELECTRICAL CHARACTERISTICS

($V_I=27V, I_O=40mA, 0 < T_j < 125^\circ C, C_1=0.33\mu F, C_o=0.1\mu F$, unless otherwise specified)(Note 1)

Characteristic	Symbol	Test conditions	MIN	TYP	MAX	UNIT
Output Voltage	Vo	T _j =25°C	17.3	18	18.7	V
		21V ≤ V _I ≤ 33V, I _O =1mA~40mA	17.1		18.9	V
		21V ≤ V _I ≤ V _{MAX} , I _O =1mA~70mA	17.1		18.9	V (note 2)
Output Voltage(note 3)	Vo	T _j =25°C	17.64	18.0	18.36	V
		21V ≤ V _I ≤ 33V, I _O =1mA~40mA	17.46		18.54	V
		21V ≤ V _I ≤ V _{MAX} , I _O =1mA~70mA	17.46		18.54	V (note 2)
Load Regulation	ΔVo	T _j =25°C, I _O =1mA~100mA		30	170	mV
		T _j =25°C, I _O =1mA~40mA		15	85	mV
Line regulation	ΔVo	21V ≤ V _I ≤ 33V, T _j =25°C		145	300	mV
		22V ≤ V _I ≤ 33V, T _j =25°C		135	250	mV
Quiescent Current	I _q			2.2	6.0	mA
Quiescent Current Change	ΔI _q	21V ≤ V _I ≤ 33V			1.5	mA
	ΔI _q	1mA ≤ V _I ≤ 40mA			0.1	mA
Output Noise Voltage	V _N	10Hz ≤ f ≤ 100kHz		150		μV
Temperature coefficient of Vo	ΔVo/ΔT	I _O =5mA		1.8		mV/°C
Ripple Rejection	RR	23V ≤ V _I ≤ 33V, f=120Hz, T _j =25°C	32	38		dB
Dropout Voltage	V _d	T _j =250°C		1.7		V

78L24 ELECTRICAL CHARACTERISTICS

(VI=33V, Io=40mA, 0<Tj<125°C, C1=0.33μF, Co=0.1μF, unless otherwise specified)(Note 1)

Characteristic	Symbol	Test conditions	MIN	TYP	MAX	UNIT
Output Voltage	Vo	Tj=25°C	23	24	25	V
		27V≤Vi≤38V, Io=1mA~40mA	22.8		25.2	V
		27V≤Vi≤VMAX, Io=1mA~70mA	22.8		25.2	V (note 2)
Output Voltage(note 3)	Vo	Tj=25°C	23.5	24	24.5	V
		27V≤Vi≤38V, Io=1mA~40mA	23.25		24.75	V
		27V≤Vi≤VMAX, Io=1mA~70mA	23.25		24.75	V (note 2)
Load Regulation	ΔVo	Tj=25°C, Io=1mA~100mA		40	200	mV
		Tj=25°C, Io=1mA~40mA		20	100	mV
Line regulation	ΔVo	27V≤Vi≤38V, Tj=25°C		160	300	mV
		28V≤Vi≤38V, Tj=25°C		150	250	mV
Quiescent Current	Iq			2.2	6.0	mA
Quiescent Current Change	ΔIq	27V≤Vi≤38V			1.5	mA
	ΔIq	1mA≤Vi≤40mA			0.1	mA
Output Noise Voltage	VN	10Hz≤f≤100kHz		200		μV
Temperature coefficient of Vo	ΔVo/ΔT	Io=5mA		2.0		mV/°C
Ripple Rejection	RR	27V≤Vi≤38V, f=120Hz, Tj=25°C	30	37		dB
Dropout Voltage	Vd	Tj=25°C		1.7		V

Note 1: The Maximum steady state usable output current and input voltage are very dependent on the heating sinking and/or lead temperature length of the package. The data above represent pulse test conditions with junction temperatures as indicated at the initiation of test.

Note 2: Power dissipation<0.75W.

Note 3: Output voltage of 78LXXA.

TYPICAL APPLICATION

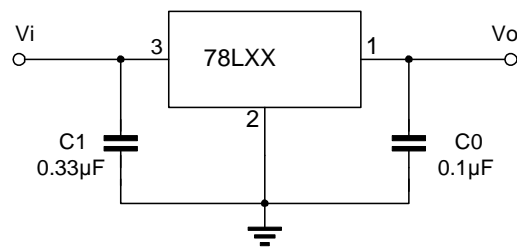

Note 1: To specify an output voltage, substitute voltage value for "XX".

Note 2: Bypass capacitors are recommended for optimum stability and transient response and should be located as close as possible to the regulators.

Fig. 1 78L05/12 Output Voltage vs Ambient Temperature

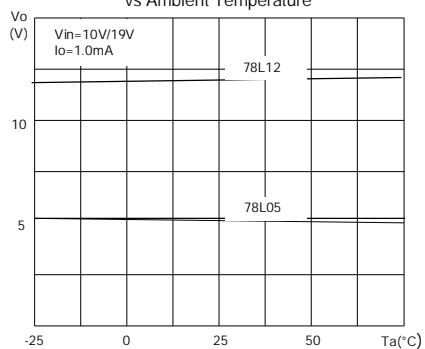

Fig 2 78L05/12 Quiescent Current vs Output Current

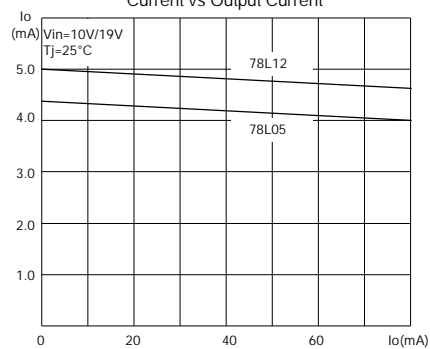

Fig.3 78L05 Quiescent Current vs Input

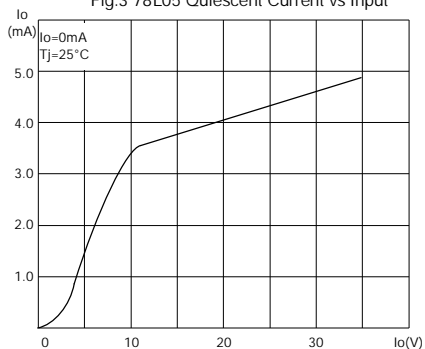

Fig.4 78L05/12/24 Thermal Shutdown

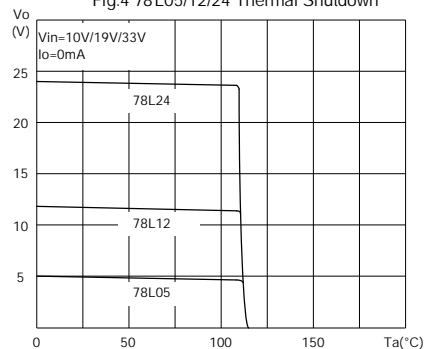

Fig.5 78L05/12/24 Output Characteristics

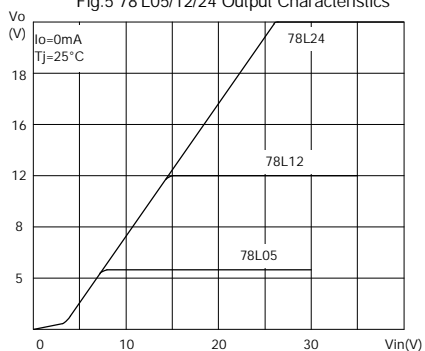
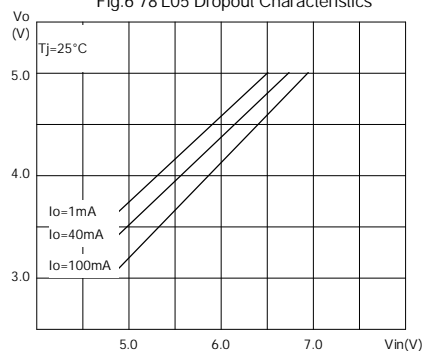
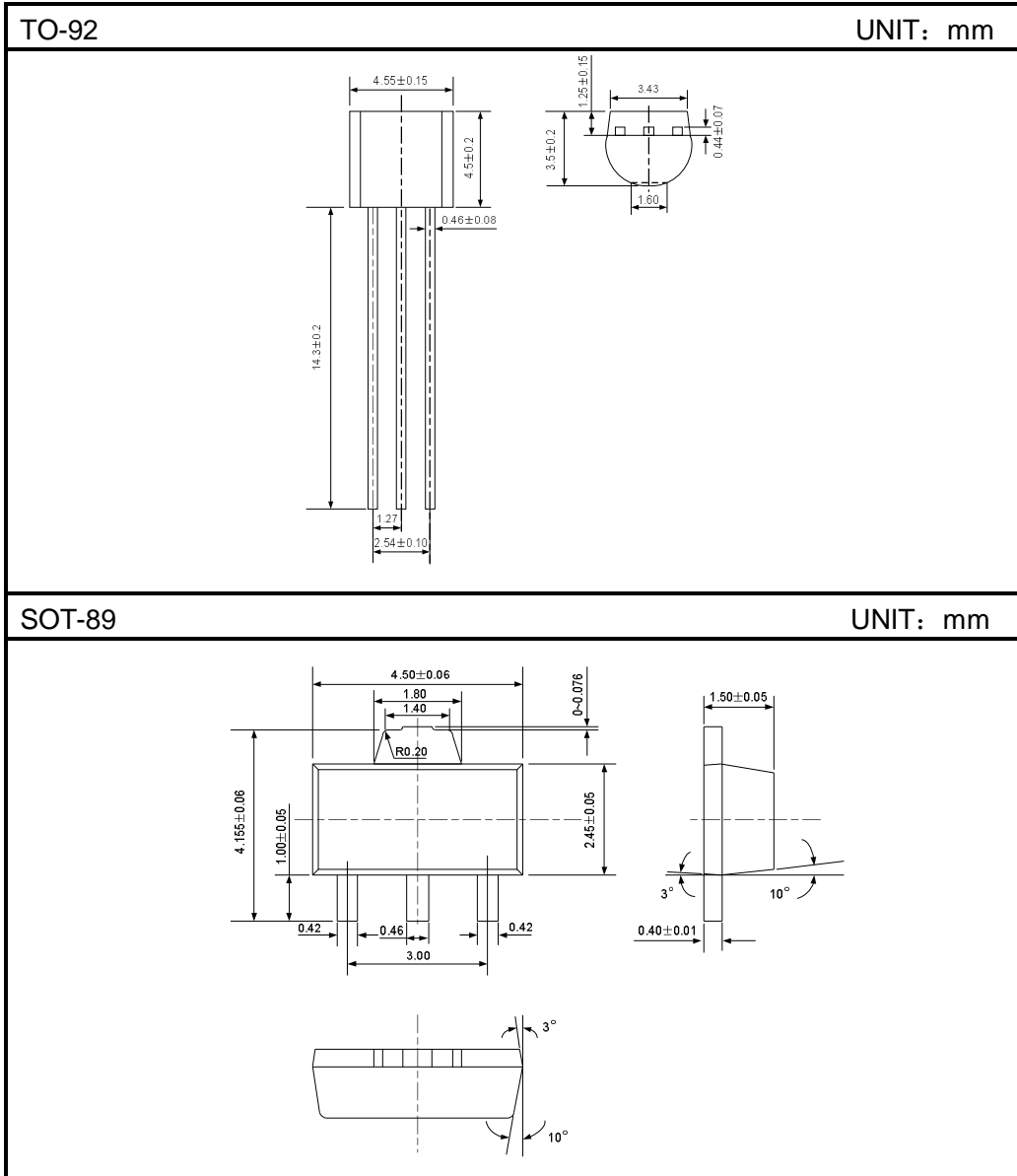

Fig.6 78L05 Dropout Characteristics



PACKAGE OUTLINE



SOP 8

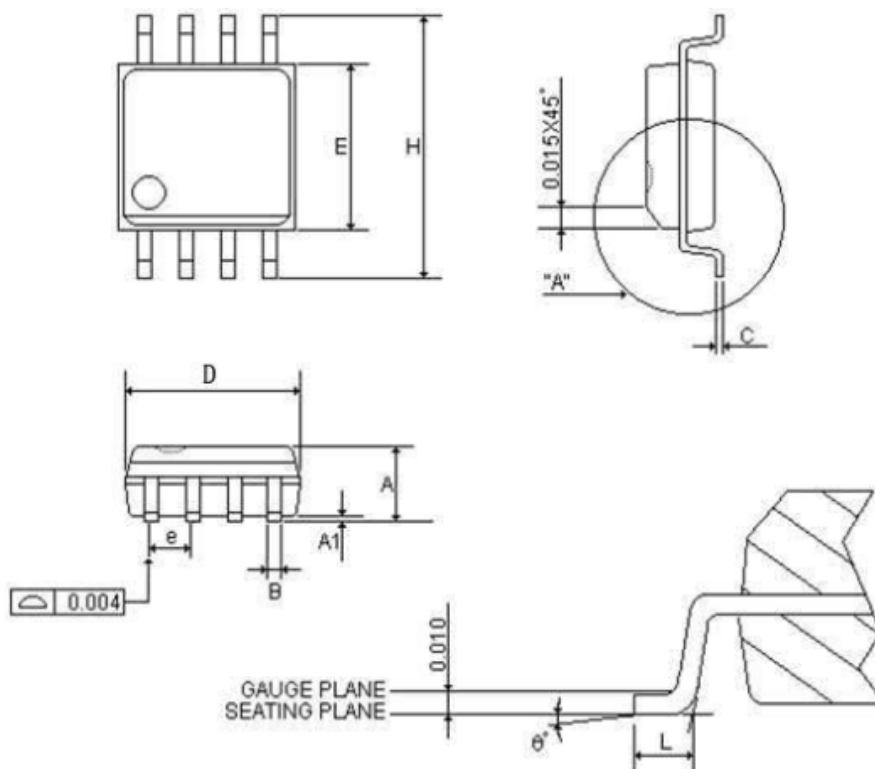

SYMBOLS	MIN	NOR	MAX	MIN	NOR	MAX
	(inch)			(mm)		
A	0.058	0.064	0.068	1.4732	1.6256	1.7272
A1	0.004	-	0.010	0.1016	-	0.254
B	0.013	0.016	0.020	0.3302	0.4064	0.508
C	0.0075	0.008	0.0098	0.1905	0.2032	0.2490
D	0.186	0.191	0.196	5.9944	6.1214	6.1976
E	0.150	0.154	0.157	3.81	3.9116	3.9878
e	-	0.050	-	-	1.27	-
H	0.228	0.236	0.244	5.7912	5.9944	6.1976
L	0.015	0.025	0.050	0.381	0.635	1.27
0°	0°	-	8°	0°	-	8°

SOT-23

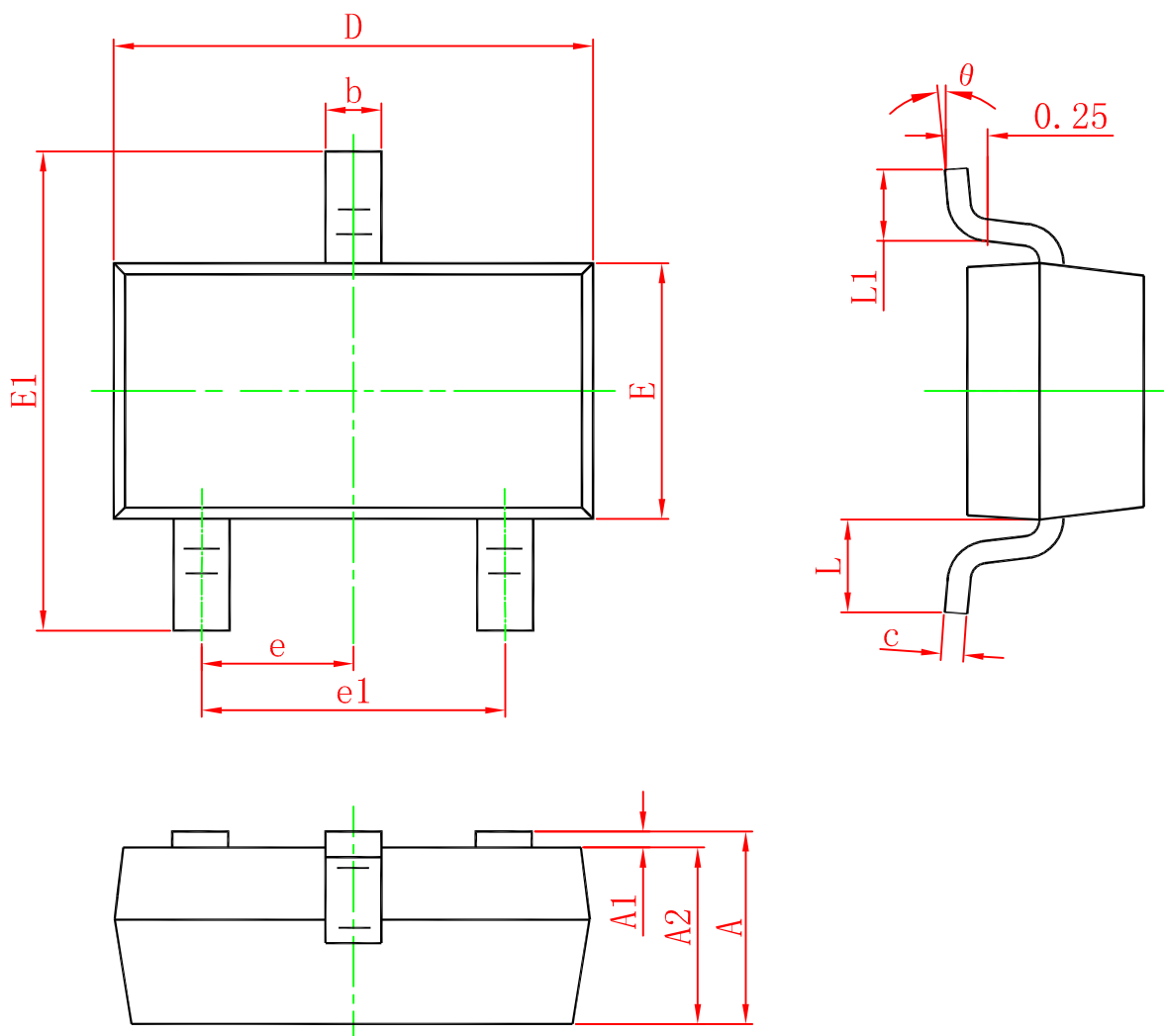

Symbol	Dimensions In Millimeters		Dimensions In Inches	
	Min.	Max.	Min.	Max.
A	0.900	1.150	0.035	0.045
A1	0.000	0.100	0.000	0.004
A2	0.900	1.050	0.035	0.041
b	0.300	0.500	0.012	0.020
c	0.080	0.150	0.003	0.006
D	2.800	3.000	0.110	0.118
E	1.200	1.400	0.047	0.055
E1	2.250	2.550	0.089	0.100
e	0.950 TYP.		0.037 TYP.	
e1	1.800	2.000	0.071	0.079
L	0.550 REF.		0.022 REF.	
L1	0.300	0.500	0.012	0.020
θ	0°	8°	0°	8°