

UTC TIP122

NPNEPITAXIAL PLANAR TRANSISTOR

NPN EPITAXIAL TRANSISTOR

DESCRIPTION

The UTC TIP122 is a NPN epitaxial transistor, designed for use in general purpose amplifier low-speed switching applications.

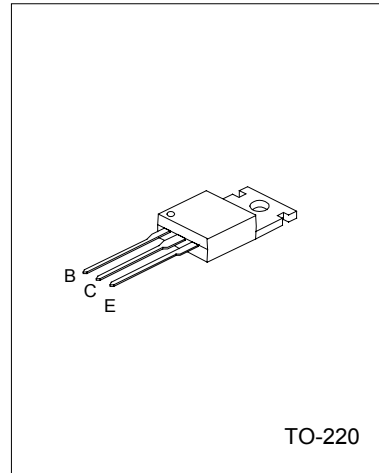

ABSOLUTE MAXIMUM RATINGS (Ta=25°C)

PARAMETER	SYMBOL	VALUE	UNIT
Storage Temperature	Ts	-55 ~ +150	°C
Junction Temperature	Tj	150	°C
Total Power Dissipation	P _D	65	W
Collector to Base Voltage	V _{CB0}	100	V
Collector to Emitter Voltage	V _{CEO}	100	V
Emitter to Base Voltage	V _{EBO}	5	V
IC Collector Current		5	A

ELECTRICAL CHARACTERISTICS(Ta=25°C)

PARAMETER	SYMBOL	TEST CONDITIONS	MIN.	TYP.	MAX.	UNIT
Collector-Emitter Breakdown Voltage	BV _{CEO}	I _C =100mA	100			V
Collector Cut-Off Current	I _{CBO}	V _{CB} =100V			200	uA
Collector-Cut-Off Current	I _{CEO}	V _{CE} =50V			500	uA
Emitter Cut-Off Current	I _{EBO}	V _{EB} =5V			2	mA
Collector-Emitter Saturation Voltage	V _{CE(SAT)1}	I _C =3A, I _B =12mA			2	V
Collector-Emitter Saturation Voltage	V _{CE(SAT)2}	I _C =5A, I _B =20mA			4	V
Base-Emitter Saturation Voltage	V _{BE(ON)}	V _{CE} =3V, I _C =3A			2.5	V
DC Current Gain	h _{FE}	I _C =500mA, V _{CE} =3V I _C =3A, V _{CE} =3V	1			K

