

SCM3425ASA High-speed CAN Transceiver

Features

- Compatible with the "ISO 11898" standard fully
- High-speed CAN, Support CANFD and data rates up to 5Mbps ;
- 5V power supply, 3.0-5.5V IO interface ;
- Receiver common mode input voltage : $\pm 30V$
- Bus Fault Protection : $\pm 42V$
- Transmit Data (TXD) Dominant Time-Out Function
- An unpowered node does not disturb the bus lines ;
- The bus supports maximum 110 nodes ;
- High Electromagnetic Immunity ;
- Meet AEC-Q100 automobile standard

Package

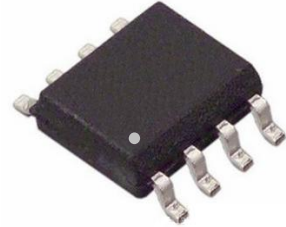

Product optional package: SOP-8, Screen Printing information please see "Order Information"

Applications

- Industrial automation
- Building automation
- Smart meter
- Long-distance signal interaction and transmission

Functional Description

The SCM3425ASA is an interface chip used between the CAN protocol controller and the physical bus. It can be used in many fields such as trucks, buses, cars, industrial control. It can reach speeds up to 5Mbps. The SCM3425ASA has the ability to differentially transmit between the bus and the CAN protocol controller.

Typical Application

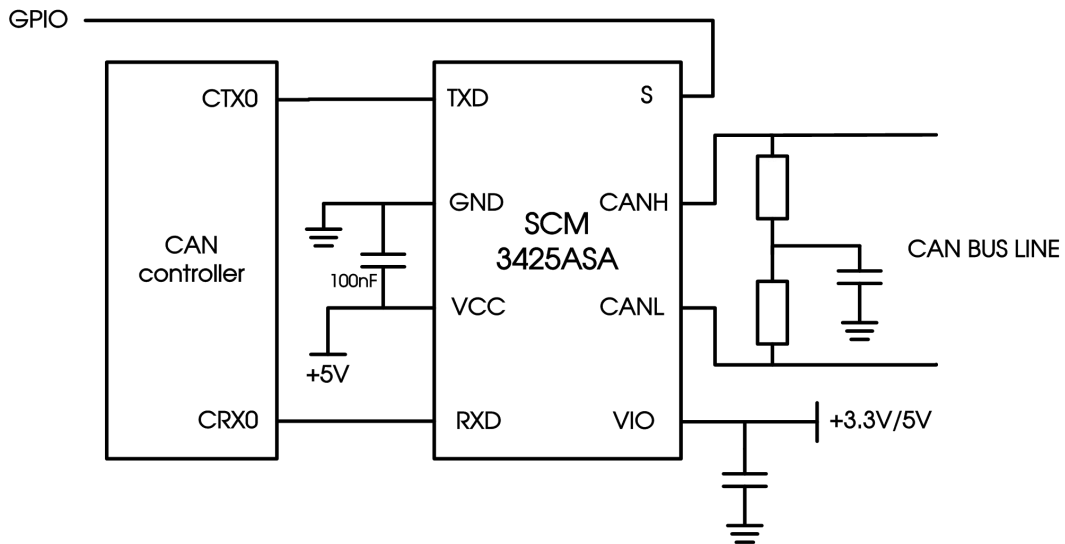

Note: GPIO means universal I/O port.

Contents

Feature and Package.....	1	Switching Characteristics.....	4
Applications.....	1	Other Characteristics.....	5
Functional Description.....	1	Parameter Test Circuit.....	5
Typical Application.....	1	General Description.....	8
Pin Package.....	2	Design Circuit Expansion.....	9
Truth Table.....	2	Power Usage Recommendations.....	9
Pin Configurations and Functions.....	3	Ordering Information.....	9
Absolute Maximum Ratings.....	3	Package Information.....	10
Recommended Operating Conditions.....	3	Tab & Reel Information.....	11
Electrical Characteristics.....	3		

Pin Package

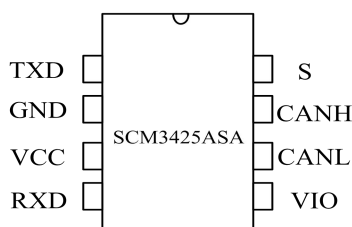

Truth Table

TABLE 1 CAN Transceiver Truth Table

VCC	TXD	S	CANH	CANL	BUS STATE	RXD
4.5 to 5.5V	L	L(Or left floating)	H	L	Dominant	L
4.5 to 5.5V	H(Or left floating)	X	0.5V _{CC}	0.5V _{CC}	Recessive	H
4.5 to 5.5V	X	H	0.5V _{CC}	0.5V _{CC}	Recessive	H
0<V _{CC} <4.75V	X	X	0V<V _{CANH} <V _{CC}	0V<V _{CANL} <V _{CC}	Recessive	X

(1)H=High-level ; L=Low-level ; Z=high resistance ; X=Any level

TABLE 2 Device function table

INPUTS		OUTPUTS		Bus State
TXD	S	CANH	CANL	
L	L(or left floating)	H	L	Dominate
H (Or left floating)	L(or left floating)	Z	Z	Recessive
X	H	Z	Z	Recessive

(2)H=High-level ; L=Low-level ; X=Any level

TABLE 3 Receiver function table

V _{ID} =CANH-CANL	RXD	Bus State
V _{ID} ≥0.9V	L	Dominate
0.4<V _{ID} <0.9V	?	?
V _{ID} ≤0.4V	H	Recessive
Open	H	Recessive

(3)H=High-level ; L=Low-level; ? =indeterminacy

Pin Configurations and Functions

Pins	Name	Pin Functions
1	TXD	Transmit data input
2	GND	Ground
3	V _{CC}	Supply voltage
4	RXD	Receive data output
5	V _{IO}	Transceiver I/O level shifting supply voltage
6	CANL	Low level CAN bus input line
7	CANH	High level CAN bus input line
8	S	Silent mode and high-speed mode (Low is high-speed)

Absolute Maximum Ratings

Sym.	Parameters	Value.	Unit.
V _{CC}	Supply Voltage	-0.3 to +7	V
V _{IO}	Transceiver I/O level shifting supply voltage	-0.3 to +7	V
TXD , RXD , S	MCU Side Port	-0.3 to +7	V
CANL , CANH	Bus Side Input Voltage	-42 to 42	V
Tstg	Storage Temperature Range	-65 to 150	°C
Tamb	Operating Ambient Temperature Range	-40 to 125	°C
T _{j(max)}	Work junction temperature	-40 to 150	°C

The maximum limit parameter value means that exceeding these values may cause irreparable damage to the device. Under these conditions, it is not conducive to the normal operation of the device. Continuous operation of the device at the maximum allowable rating may affect device reliability. The reference point for all voltages is ground.

Recommended Operating Conditions

Parameters	Sym.	Test Conditions	Min.	Max.	Units
Supply Voltage	V _{CC}		4.5	5.5	V
Transceiver I/O level shifting supply voltage	V _{IO}		3.0	5.5	V
Maximum Baud Rate	1/tbit	Non-return to zero code	5		Mbaud
CANH, CANL, Input Voltage	V _{can}		-42	+42	V
BUS Differential Output Voltage	V _{diff}		1.5	3.0	V
Operating Ambient Temperature Range	Tamb		-40	125	°C

Electrical Characteristics

Unless otherwise stated, V_{CC}=5V±5%, Temp=TMIN to TMAX, typical value is V_{CC}=+5V, Temp=25°C

Driver Electrical Characteristics						
Sym.	Parameters	Test Conditions	Min.	Typ	Max.	Units
V _{IH}	High-level input voltage	TXD	0.7V _{IO}			V
V _{IL}	Low-level input voltage	TXD			0.3V _{IO}	V
I _{IH}	High-level input leakage current	TXD, S = V _{CC} or V _{IO} = 5.5 V	-2.5	0	1	uA
I _{IL}	Low-level input leakage current	TXD, S = 0 V, V _{CC} = V _{IO} = 5.5 V	-100	-63	-7	
I _{lkg(OFF)}	Unpowered leakage current	TXD, TXD = 5.5 V, V _{CC} = V _{IO} = 0 V	-1	0	1	
C _I	Input capacitance	V _{IN} = 0.4 * sin(4E6 * π * t) + 2.5 V		4.5		pF
V _{OH(D)}	CANH output voltage(dominant)	V _I =0V, S=0V, R _L =60Ω	2.75		4.5	V
V _{OL(D)}	CANL output voltage(dominant)	Figure 1, Figure 2	0.5		2.25	V
V _{O(R)}	Output voltage(recessive)	V _I =3V, S=0V, R _L =60Ω, Figure 1, Figure 2	2	0.5V _{CC}	3	V
V _{OD(D)}	Bus differential output voltage (dominant)	V _I =0V, S=0V, 45Ω≤R _L < 50Ω, Figure 1, Figure 2	1.4		3	V
		V _I =0V, S=0V, 50Ω≤R _L ≤65Ω, Figure 1, Figure 2	1.5		3	V
		V _I =0V, S=0V, R _L =2240Ω, Figure 1, Figure 2	1.5		5	V
V _{OD(R)}	Differential output voltage(recessive)	V _I =3V, S=0V, R _L =60Ω, Figure 1, Figure 2	-0.12		0.012	V
		V _I =3V, S=0V, NO LOAD	-0.05		0.05	V
V _{dom(TX)sym}	Dominant output voltage symmetry	V _{dom(TX)sym} =V _{CC} - V _{CANH} - V _{CANL}	-1	0.2	1	V
V _{TXsym}	Output voltage symmetry	V _{TXsym} = V _{CANH} + V _{CANL}		1		V/V
V _{OC}	Common-mode output voltage	S=0V, Figure 8	2	2.5	3	V
I _{OS}	Short-circuit output current	S=0V, V _{CANL} =-5V to 40V, CANH=open, TXD=0V Figure 11	-100			mA
		S=0V, V _{CANL} =-5V to 40V, CANH=open, TXD=0V Figure 11			100	
I _{O(R)}	Output current(recessive)	-27V<V _{BUS} <32V 0<V _{CC} <5.25V	-5		5	mA

Receiver Electrical Characteristics						
Sym.	Parameters	Test Conditions	Min.	Typ	Max.	Units
V _{IT+}	Positive-going input threshold voltage	S=0V, -20V ≤ V _{CM} ≤ 20V, Figure5			900	mV
V _{IT-}	Negative-going input threshold voltage		400			
V _{IT+}	Positive-going input threshold voltage	S=0V, -30V ≤ V _{CM} ≤ 30V, Figure5			1000	
V _{IT-}	Negative-going input threshold voltage		400			
V _{HYS}	Hysteresis voltage (V _{IT+} - V _{IT-})			115		
V _{OH}	High-level output voltage	IO=-2mA, Figure6	0.8V _{IO}			V
V _{OL}	Low-level output voltage	IO=2mA, Figure6			0.2V _{IO}	V
I _(OFF)	Unpowered input current	CANH or CANL=5V , Other pin=0V	-1	0	1	uA
C _I	Input capacitance to ground (CANH or CANL)			27		pF
C _{ID}	Differential input capacitance			14		pF
R _{IN}	Input resistance (CANH or CANL)	TXD=3V, S=0V	15		40	kΩ
R _{ID}	Differential input resistance		30		80	kΩ
R _I match	Input resistance matching: [1 - R _{IN} (CANH) / R _{IN} (CANL)] × 100%	CANH=CANL	-2%		2%	
V _{COM}	Common mode range		-30		30	V

Power Supply Features						
Sym.	Parameters	Test Conditions	Min.	Typ	Max.	Units
I _{CC}	Silent mode power dissipation	S=V _{CC} , V _I =V _{CC}		1.3	2.5	mA
	Dominant power dissipation	V _I =0V, S=0V, LOAD=60Ω		50	70	mA
		V _I =0V, S=0V, LOAD=50Ω		52	80	mA
	Recessive power dissipation	V _I =V _{CC} , S=0V, NO LOAD		1.3	2.5	mA
I _{IO}	Normal and Silent modes	RXD, TXD=S=0 or V _{IO}		73	300	uA
UV _{VCC}	Rising undervoltage detection on V _{CC} for protected mode			4.0	4.4	V
	Falling undervoltage detection on V _{CC} for protected mode		3.6	3.9	4.15	V
V _{HYS(UVCC)}	Hysteresis voltage on V _{CC} for protected mode			200		mV
UV _{VIO}	Rising undervoltage detection on V _{IO} for protected mode		1.3		2.75	V
V _{HYS(UVIO)}	Hysteresis voltage on V _{IO} for protected mode			150		mV

S-pin Characteristics						
Sym.	Parameters	Test Conditions	Min.	Typ	Max.	Units
V _{IH}	High-level input voltage		0.7V _{IO}			V
V _{IL}	Low-level input voltage				0.3V _{IO}	V
I _{IH}	High-level leakage current	S = V _{CC} or V _{IO} = 5.5 V			30	uA
I _{IL}	Low-level leakage current	S = 0 V, V _{CC} = V _{IO} = 5.5 V	-2	0	2	uA
I _{Ikg(OFF)}	Unpowered leakage current	S = 5.5 V, V _{CC} = V _{IO} = 0 V	-1	0	1	uA

Switching Characteristics

Unless otherwise stated, V_{CC}=5V±5%, Temp=TMIN to TMAX, typical value is V_{CC}=+5V, Temp=25°C

Driver Switching Characteristics						
Sym.	Parameters	Test Conditions	Min.	Typ	Max.	Units
t _{PLH}	Driver propagation delay(L to H)	S=0V, Figure4		70		ns
t _{PHL}	Driver propagation delay(H to L)			42		ns
t _r	Driver differential-output rise time			45		ns
t _f	Driver differential-output fall time			45		ns
t _{dom}	Dominant time-out time	Figure10	1.2		3.8	ms

Receiver Switching Characteristics						
Sym.	Parameters	Test Conditions	Min.	Typ	Max.	Units
t _{PLH}	Receiver propagation delay(L to H)	S=0V or V _{CC} , Figure6		78		ns
t _{PHL}	Receiver propagation delay(H to L)			59		ns
t _r	Receiver output rise time			10		ns
t _f	Receiver output fall time			10		ns

Device Switching Characteristics						
$T_{d(LOOP1)}$	Total loop delay1, driver input (TXD) to receiver output (RXD), recessive to dominant	Figure9, S=0V		100	160	ns
$T_{d(LOOP2)}$	Total loop delay2, driver input (TXD) to receiver output (RXD), dominant to recessive			110	175	ns
T_{MODE}	Mode conversion time			0.15	10	us

Other Characteristics

Unless otherwise stated, VCC=5V±5%, Temp=TMIN toTMAX, typical value is VCC=+5V, Temp=25°C

TXD Characteristics						
Sym.	Parameters	Test Conditions	Min.	Typ	Max.	Units
$I_{IH(TXD)}$	TXD Pin High-level input current	$V_I=V_{CC}$	-2.5	0	1	uA
$I_{IL(TXD)}$	TXD Pin Low-level input current	$V_I=0$	-100	-63	-7	uA
$I_{O(off)}$	$V_{CC}=0V$, Current of TXD	$V_{CC}=0V$, TXD=5V	-1	0	1	uA
V_{IH}	High-level input voltage		0.7V _{IO}			V
V_{IL}	Low-level input voltage				0.3V _{IO}	V
C_I	Input capacitance			4.5		pF
TXDO	TXD port suspension voltage			H		logic

Parameter Test Circuit

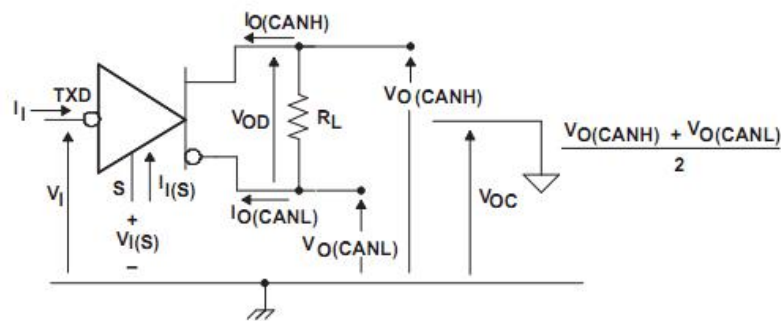

Figure 1. Driver Voltage, Current Test Definition

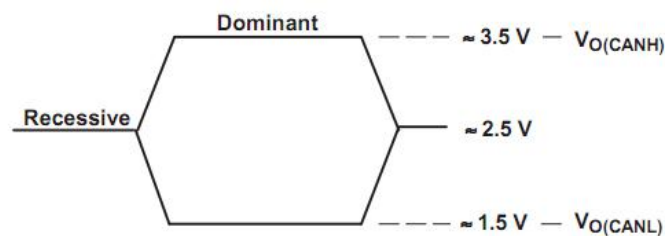

Figure 2. Bus Logic Voltage Definition

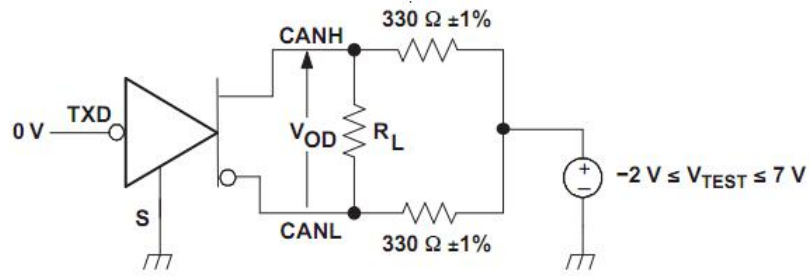

Figure 3. Driver VOD Test Circuit

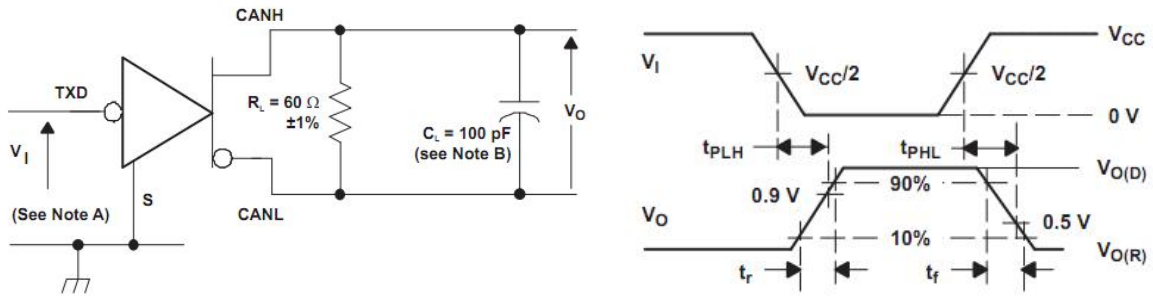

Figure 4. Driver Test Circuit and Voltage Waveforms

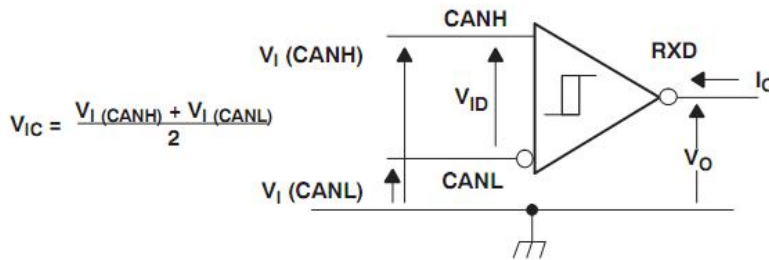
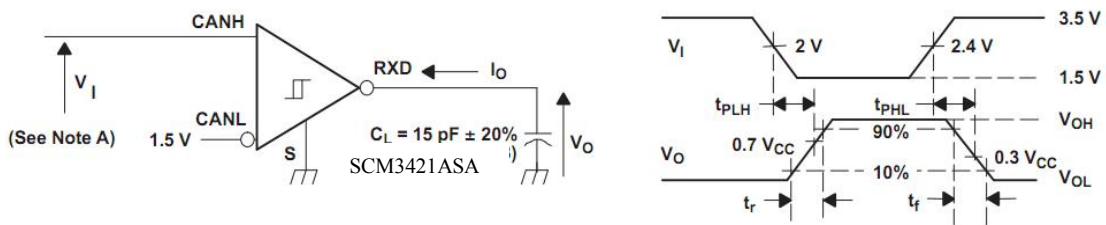

Figure 5. Receiver Voltage and Current Definition



- A. Input pulse generator characteristics: $PRR \leq 125\text{kHz}$, duty cycle = 50%, $t_r < 6\text{ns}$, $t_f < 6\text{ns}$, $Z_o = 50\Omega$
 B. C_L includes instrument and fixed capacitor, the error is within 20%.

Figure 6. Receiver Test Circuit and Voltage Waveforms

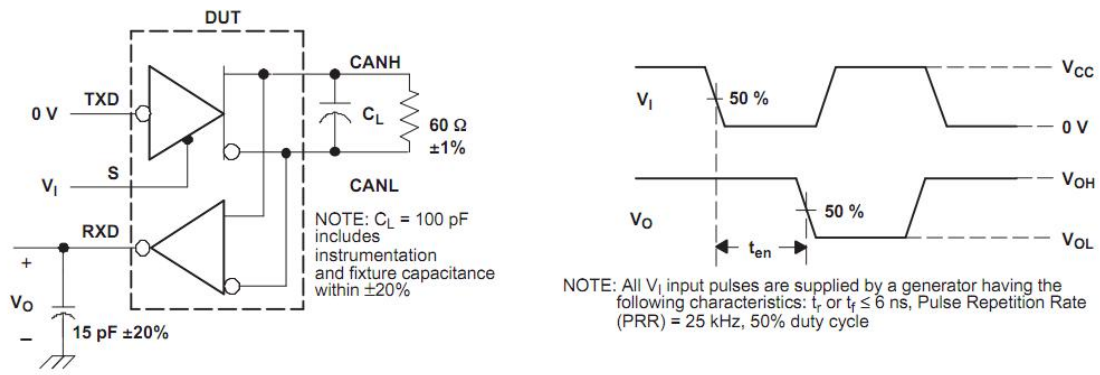
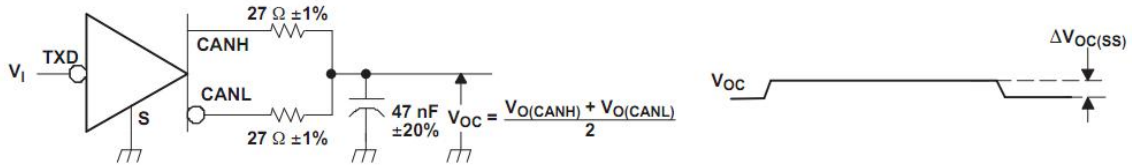

Figure 7. tEN Test Circuit and Voltage Waveforms



NOTE: V_I from 0-VCC input pulse generator features: PRR < 125kHz 50% duty cycle $TR < 6 \text{ ns}$ $TF < 6 \text{ ns}$ $Z_o = 50 \Omega$

Figure 8. Common Mode Output Voltage Test and Waveforms

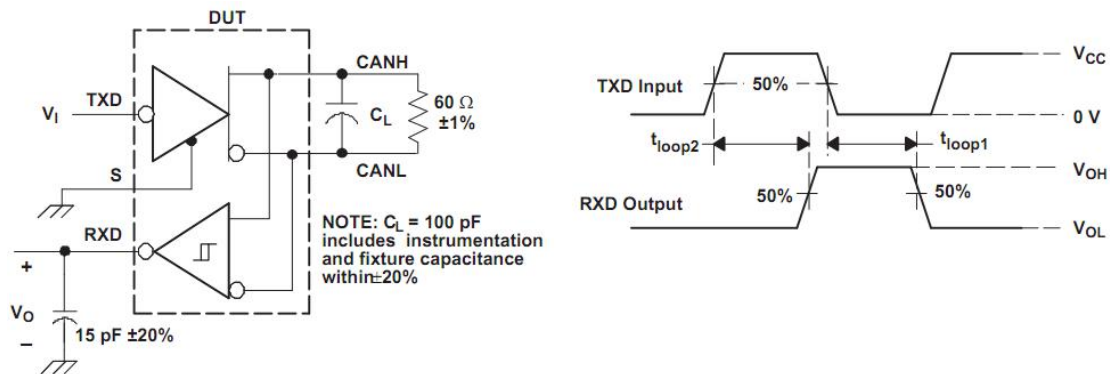

Figure 9. t(LOOP) Test Circuit and Waveforms

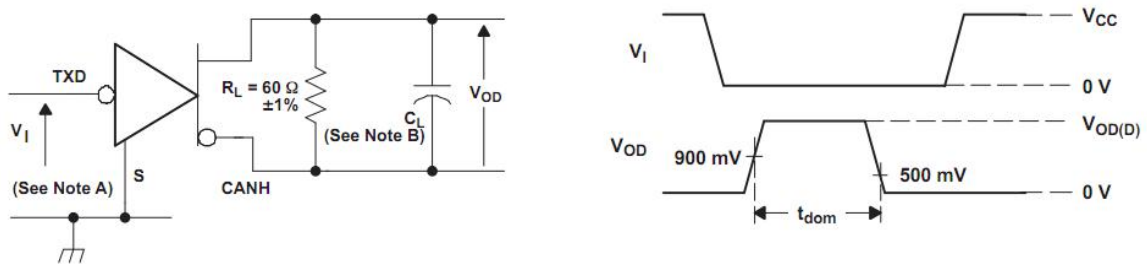

Figure 10. Dominant Time-out Test Circuit and Waveforms

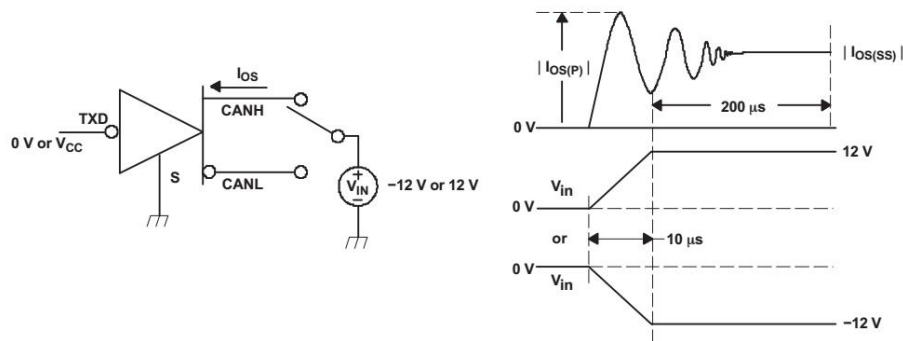

Figure 11. The Driver Short-circuit Current Test Circuit and Waveforms

General Description

The SCM3425ASA is an interface chip used between the CAN protocol controller and the physical bus. It can be used in many fields such as trucks, buses, cars, industrial control. It can reach speeds up to 5Mbps. The SCM3425ASA has the ability to differentially transmit between the bus and the CAN protocol controller. SCM3425ASA is compatible with the "ISO 11898" standard.

Short-circuit protection: The drive stage of the SCM3425ASA has current-limiting protection to prevent the drive circuit from short-circuiting to positive and negative supply voltages. The power dissipation increases when a short circuit occurs. The short-circuit protection function protects the driver stage from damage.

Over-temperature protection: The SCM3425ASA has over-temperature protection. When the junction temperature exceeds 160°C, the current in the driver stage will decrease. Because the drive tube is the primary energy consuming component, current reduction can reduce power consumption and reduce chip temperature. At the same time, the rest of the chip remains functional.

Dominant time-out function: If the pin TXD is forced to a permanent low level due to a hardware or software application failure, the built-in TXD dominant timeout timer circuit prevents the bus line from being driven to a permanent dominant state (blocking all network traffic). The timer is triggered by the negative edge on pin TXD. If the low level on pin TXD lasts longer than the internal timer value (tdom), the transmitter will be disabled and the drive bus will enter a recessive state. The timer is reset by the positive edge on pin TXD.

Control mode: Control pin S allows two operating modes to be selected: high speed mode or silent mode.

The high speed mode is the normal operating mode and is selected by grounding the pin S. If pin S is not connected, it is the default mode. However, to ensure EMI performance in applications that only use high speed mode, it is recommended to ground pin S.

In silent mode, the transmitter is disabled. All other IC functions continue to run. The silent mode is selected by connecting pin S to V_{CC} and can be used to prevent network communication congestion due to out of control of the CAN controller.

Design Circuit Expansion

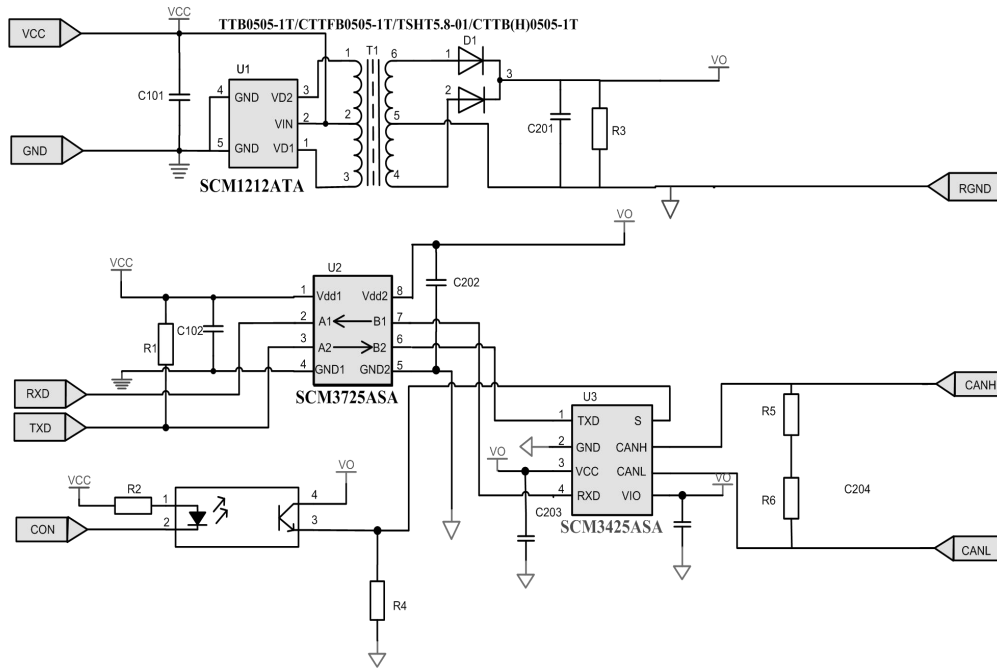

Figure 12. Isolated Application Circuit Schematic for Converting TTL/CMOS to CAN Bus

Power Usage Recommendations

Connecting the 0.1 μ F bypass capacitor as close as possible to the V_{CC} pin of the device.

Ordering Information

Product number	Package Type	Pins	Screen Printing
SCM3425ASA	SOP	8	SCM 3425A YM

Product model and Screen Printing instructions:

SCM3425XYZ:

(1)SCM3425, Product Code.

(2)X = A-Z, Version code.

(3)Y = S Package code; S: SOP package; F: DFN package;

(4)Z = C, I, A, M, Temperature class code; C: 0 $^{\circ}$ C - 70 $^{\circ}$ C, I: -40 $^{\circ}$ C - 85 $^{\circ}$ C, A: -40 $^{\circ}$ C - 125 $^{\circ}$ C, M: -55 $^{\circ}$ C - 125 $^{\circ}$ C.

(5)YM: Product traceability code; Y: Product year code, M: Product production month code.

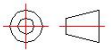
THIRD ANGLE PROJECTION 

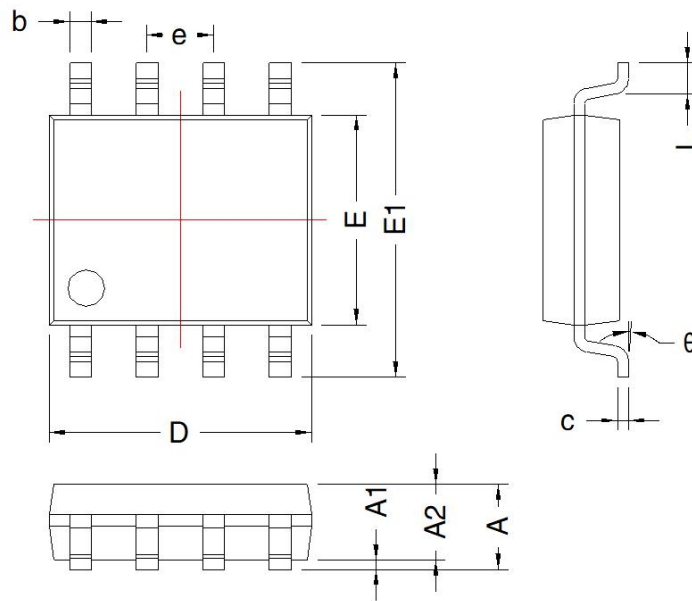

SOP-8				
Mark	Dimension(mm)		Dimension(inch)	
	Min	Max	Min	Max
A	1.40	1.80	0.055	0.071
A1	0.05	0.25	0.002	0.010
A2	1.35	1.55	0.053	0.061
D	4.80	5.00	0.189	0.197
E	3.80	4.00	0.150	0.157
E1	5.80	6.20	0.228	0.244
L	0.45	1.00	0.018	0.39
b	0.30	0.50	0.012	0.020
e	1.27BSC		0.05BSC	
c	0.153	0.253	0.006	0.010
theta	2°	6°	2°	6°

Tape & Reel Information

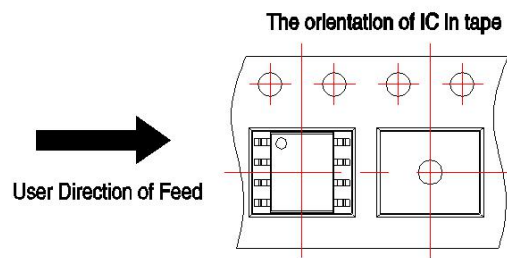
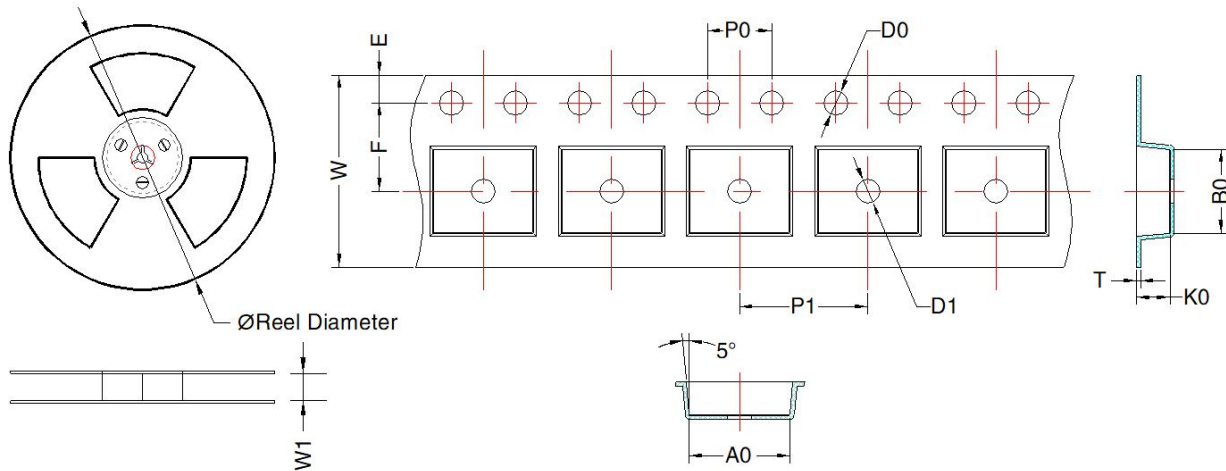

Device	Package Type	MPQ	Reel Diameter (mm)	Reel Width W1 (mm)	A0 (mm)	B0 (mm)	K0 (mm)	T (mm)	W (mm)	E (mm)	F (mm)	P1 (mm)	P0 (mm)	D0 (mm)	D1 (mm)
SCM3425ASA	SOP-8	3000	330.0	12.4	6.5 ± 0.2	5.45 ± 0.2	2.0 ± 0.2	0.3 ± 0.05	12.0 ± 0.3	1.75 ± 0.1	5.5 ± 0.1	8.0 ± 0.1	4 ± 0.1	1.5 ± 0.1	1.5 ± 0.1

MORNSUN Guangzhou Science & Technology Co., Ltd.

Address: No. 5, Kehui St. 1, Kehui Development Center, Science Ave., Guangzhou Science City, Huangpu District, Guangzhou, P. R. China
 Tel: 86-20-38601850 Fax: 86-20-38601272 E-mail: info@mornsun.cn www.mornsun-power.com