

Part No.		Package Description	Material	λ D (nm)	Iv (ucd) @10mA		Package Dimension
Common Anode	Common Cathode				Min.	Typ.	
DA56-51EWA	DC56-51EWA	0.56 inch (14.22mm) Gray Face White Segment	GaAsP/GaP	625	3000	12000	23
DA56-51YWA	DC56-51YWA		GaAsP/GaP	588	1200	5300	
DA56-51GWA	DC56-51GWA		GaP	568	3000	14400	
DA08-11EWA	DC08-11EWA	0.8 inch (20.32mm) Gray Face White Segment	GaAsP/GaP	625	1900	8000	24
DA08-11SRWA	DC08-11SRWA		GaAlAs	640	4700	24000	
DA08-11YWA	DC08-11YWA		GaAsP/GaP	588	1200	4700	
DA08-11GWA	DC08-11GWA		GaP	568	1900	10500	
BA56-11EWA BA56-12EWA BA56-13EWA	BC56-11EWA BC56-12EWA BC56-13EWA	0.56 inch (14.22mm) Gray Face White Segment	GaAsP/GaP	625	1200	6400	25
BA56-11SRWA BA56-12SRWA BA56-13SRWA	BC56-11SRWA BC56-12SRWA BC56-13SRWA		GaAlAs	640	4700	24000	
BA56-11YWA BA56-12YWA BA56-13YWA	BC56-11YWA BC56-12YWA BC56-13YWA		GaAsP/GaP	588	1200	4700	
BA56-11GWA BA56-12GWA BA56-13GWA	BC56-11GWA BC56-12GWA BC56-13GWA		GaP	568	1900	10500	
PSA39-21EWA	PSC39-21EWA	0.39 inch (9.9mm) Gray Face White Segment	GaAsP/GaP	625	1200	3188	26
PSA39-21SRWA	PSC39-21SRWA		GaAlAs	640	3000	13250	
PSA39-21YWA	PSC39-21YWA		GaAsP/GaP	588	480	1278	
PSA39-21GWA	PSC39-21GWA		GaP	568	1200	2679	
PSA05-11EWA PSA05-12EWA	PSC05-11EWA PSC05-12EWA	0.5 inch (12.7mm) Gray Face White Segment	GaAsP/GaP	625	800	4100	27
PSA05-11SRWA PSA05-12SRWA	PSC05-11SRWA PSC05-12SRWA		GaAlAs	640	4700	18000	
PSA05-11YWA PSA05-12YWA	PSC05-11YWA PSC05-12YWA		GaAsP/GaP	588	800	3000	
PSA05-11GWA PSA05-12GWA	PSC05-11GWA PSC05-12GWA		GaP	568	1200	4700	

NOTES:

1. All dimensions are in millimeters(inches).
2. Tolerance is ±0.25mm(0.01") unless otherwise noted.

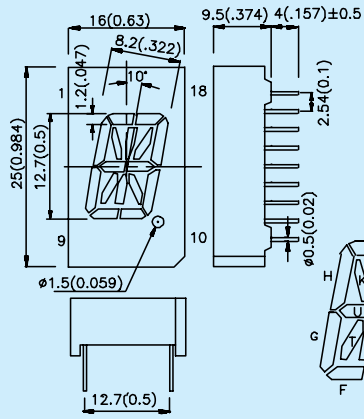

PSA05-11

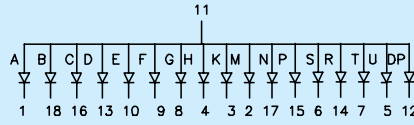

PSA05-12

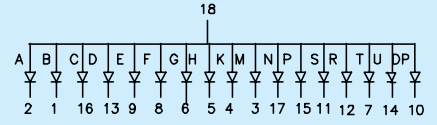

PSC05-11

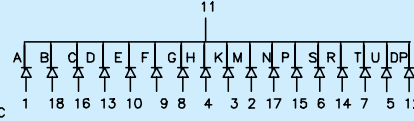

PSC05-12

