



# M24M01-R M24M01-DF

## 1-Mbit serial I<sup>2</sup>C bus EEPROM

Datasheet – production data

### Features

- Compatible with all I<sup>2</sup>C bus modes:
  - 1 MHz
  - 400 kHz
  - 100 kHz
- Memory array:
  - 1 Mbit (128 Kbytes) of EEPROM
  - Page size: 256 bytes
  - Additional Write lockable page (M24M01-D order codes)
- Single supply voltage and high speed:
  - 1 MHz clock from 1.7 V to 5.5 V
- Write:
  - Byte Write within 5 ms
  - Page Write within 5 ms
- Operating temperature range: from -40 °C up to +85 °C
- Random and sequential Read modes
- Write protect of the whole memory array
- Enhanced ESD/Latch-Up protection
- More than 4 million Write cycles
- More than 200-year data retention
- Packages:
  - RoHS compliant and halogen-free (ECOPACK<sup>®</sup>)

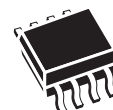

SO8 (MN)  
150 mil width

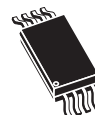

TSSOP8 (DW)



WLCSP (CS)

# Contents

- 1 Description . . . . . 6**
- 2 Signal description . . . . . 8**
  - 2.1 Serial Clock (SCL) . . . . . 8
  - 2.2 Serial Data (SDA) . . . . . 8
  - 2.3 Chip Enable (E1, E2) . . . . . 8
  - 2.4 Write Control ( $\overline{WC}$ ) . . . . . 8
  - 2.5  $V_{SS}$  (ground) . . . . . 8
  - 2.6 Supply voltage ( $V_{CC}$ ) . . . . . 9
    - 2.6.1 Operating supply voltage  $V_{CC}$  . . . . . 9
    - 2.6.2 Power-up conditions . . . . . 9
    - 2.6.3 Device reset . . . . . 9
    - 2.6.4 Power-down conditions . . . . . 9
- 3 Memory organization . . . . . 10**
- 4 Device operation . . . . . 11**
  - 4.1 Start condition . . . . . 12
  - 4.2 Stop condition . . . . . 12
  - 4.3 Data input . . . . . 12
  - 4.4 Acknowledge bit (ACK) . . . . . 12
  - 4.5 Device addressing . . . . . 13
- 5 Instructions . . . . . 14**
  - 5.1 Write operations . . . . . 14
    - 5.1.1 Byte Write . . . . . 15
    - 5.1.2 Page Write . . . . . 16
    - 5.1.3 Write Identification Page (M24M01-D only) . . . . . 17
    - 5.1.4 Lock Identification Page (M24M01-D only) . . . . . 17
    - 5.1.5 ECC (Error Correction Code) and Write cycling . . . . . 18
    - 5.1.6 Minimizing Write delays by polling on ACK . . . . . 19
  - 5.2 Read operations . . . . . 20
    - 5.2.1 Random Address Read . . . . . 21

---

5.2.2	Current Address Read .....	21
5.2.3	Sequential Read .....	21
5.3	Read Identification Page (M24M01-D only) .....	21
5.4	Read the lock status (M24M01-D only) .....	22
<b>6</b>	<b>Initial delivery state .....</b>	<b>22</b>
<b>7</b>	<b>Maximum rating .....</b>	<b>23</b>
<b>8</b>	<b>DC and AC parameters .....</b>	<b>24</b>
<b>9</b>	<b>Package mechanical data .....</b>	<b>32</b>
<b>10</b>	<b>Part numbering .....</b>	<b>36</b>
<b>11</b>	<b>Revision history .....</b>	<b>37</b>

## List of tables

Table 1.	Signal names . . . . .	6
Table 2.	Device select code . . . . .	13
Table 3.	Most significant address byte . . . . .	14
Table 4.	Least significant address byte . . . . .	14
Table 5.	Absolute maximum ratings . . . . .	23
Table 6.	Operating conditions (voltage range R) . . . . .	24
Table 7.	Operating conditions (voltage range F) . . . . .	24
Table 8.	AC measurement conditions. . . . .	24
Table 9.	Input parameters. . . . .	24
Table 10.	Cycling performance by groups of four bytes . . . . .	25
Table 11.	Memory cell data retention . . . . .	25
Table 12.	DC characteristics (M24M01-R, device grade 6) . . . . .	26
Table 13.	DC characteristics (M24M01-F, device grade 6) . . . . .	27
Table 14.	400 kHz AC characteristics. . . . .	28
Table 15.	1 MHz AC characteristics . . . . .	29
Table 16.	TSSOP8 – 8-lead thin shrink small outline, package mechanical data. . . . .	32
Table 17.	SO8N – 8 lead plastic small outline, 150 mils body width, package data. . . . .	33
Table 18.	M24M01-DFCS6TP/K, WLCSP 8-bump wafer-level chip scale package mechanical data	35
Table 19.	Ordering information scheme . . . . .	36
Table 20.	Document revision history . . . . .	37

## List of figures

Figure 1.	Logic diagram . . . . .	6
Figure 2.	8-pin package connections . . . . .	7
Figure 3.	WLCSP connections for M24M01 DFCS6TP/K (top view, marking side, with balls on the underside) . . . . .	7
Figure 4.	Device select code . . . . .	8
Figure 5.	Block diagram . . . . .	10
Figure 6.	I <sup>2</sup> C bus protocol . . . . .	11
Figure 7.	Write mode sequences with $\overline{WC} = 0$ (data write enabled) . . . . .	15
Figure 8.	Write mode sequences with $\overline{WC} = 1$ (data write inhibited) . . . . .	16
Figure 9.	Write cycle polling flowchart using ACK . . . . .	19
Figure 10.	Read mode sequences . . . . .	20
Figure 11.	AC measurement I/O waveform . . . . .	24
Figure 12.	Maximum $R_{bus}$ value versus bus parasitic capacitance ( $C_{bus}$ ) for an I <sup>2</sup> C bus at maximum frequency $f_C = 400$ kHz . . . . .	30
Figure 13.	Maximum $R_{bus}$ value versus bus parasitic capacitance $C_{bus}$ for an I <sup>2</sup> C bus at maximum frequency $f_C = 1$ MHz . . . . .	30
Figure 14.	AC waveforms . . . . .	31
Figure 15.	TSSOP8 – 8-lead thin shrink small outline, package outline . . . . .	32
Figure 16.	SO8N – 8 lead plastic small outline, 150 mils body width, package outline . . . . .	33
Figure 17.	M24M01 DFCS6TP/K, WLCSP 8-bump wafer-level chip scale package outline . . . . .	34

# 1 Description

The M24M01 is a 1 Mb I<sup>2</sup>C-compatible EEPROM (Electrically Erasable PROgrammable Memory) organized as 128 K × 8 bits.

The M24M01-R can operate with a supply voltage from 1.8 V to 5.5 V, and the M24M01-DF can operate with a supply voltage from 1.7 V to 5.5 V, over an ambient temperature range of -40 °C / +85 °C.

The M24M01-D offers an additional page, named the Identification Page (256 bytes). The Identification Page can be used to store sensitive application parameters which can be (later) permanently locked in Read-only mode.

**Figure 1. Logic diagram**

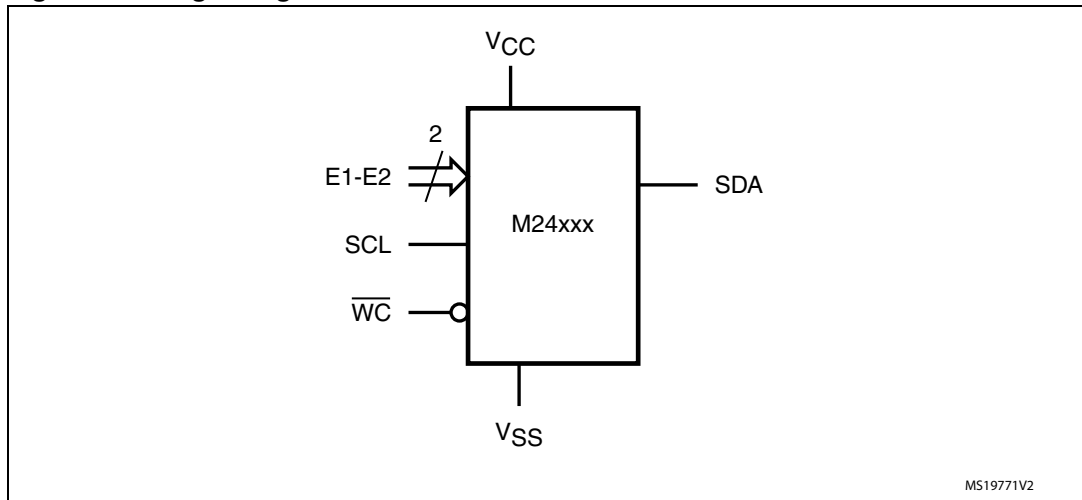

**Table 1. Signal names**

Signal name	Function	Direction
E1, E2	Chip Enable	Input
SDA	Serial Data	I/O
SCL	Serial Clock	Input
$\overline{WC}$	Write Control	Input
V <sub>CC</sub>	Supply voltage	
V <sub>SS</sub>	Ground	

**Figure 2. 8-pin package connections**

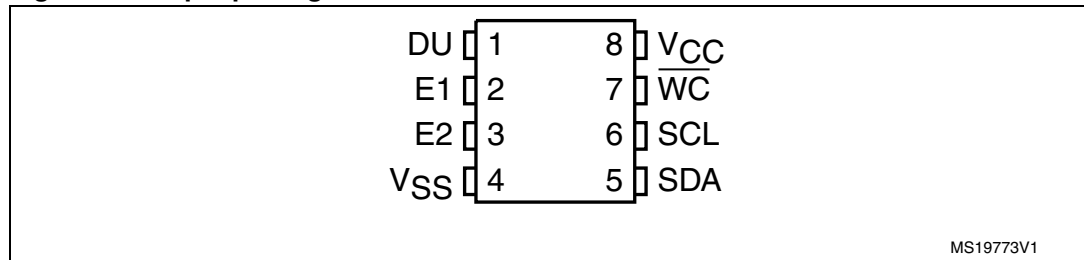

1. DU: Don't Use (if connected, must be connected to V<sub>SS</sub>)
2. See [Section 9: Package mechanical data](#) for package dimensions, and how to identify pin 1.

**Figure 3. WLCSP connections for M24M01 DFCS6TP/K (top view, marking side, with balls on the underside)**

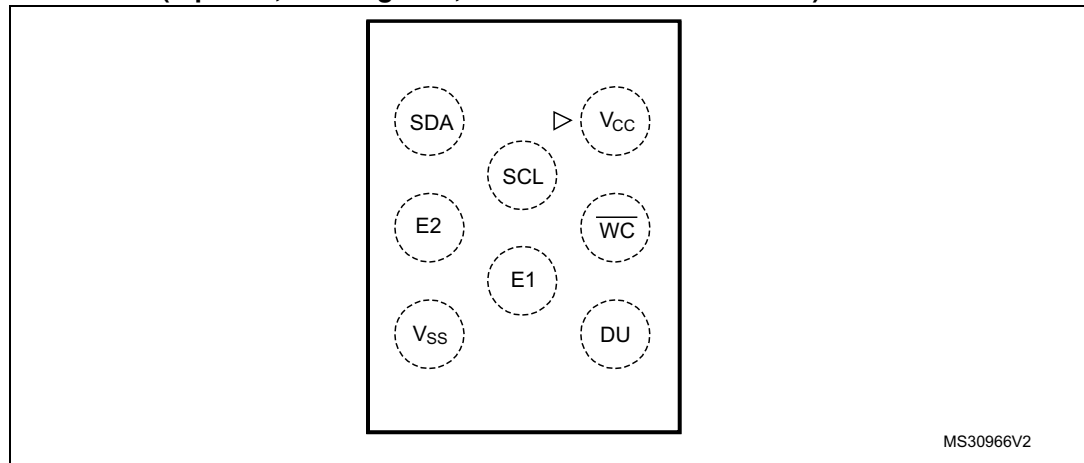

3. DU: Don't Use (if connected, must be connected to V<sub>SS</sub>)
4. See [Section 9: Package mechanical data](#) for package dimensions, and how to identify pin 1.

## 2 Signal description

### 2.1 Serial Clock (SCL)

The signal applied on the SCL input is used to strobe the data available on SDA(in) and to output the data on SDA(out).

### 2.2 Serial Data (SDA)

SDA is an input/output used to transfer data in or data out of the device. SDA(out) is an open drain output that may be wire-OR'ed with other open drain or open collector signals on the bus. A pull-up resistor must be connected ([Figure 12](#) indicates how to calculate the value of the pull-up resistor).

### 2.3 Chip Enable (E1, E2)

These input signals are used to set the value that is to be looked for on the two bits (b3, b2) of the 7-bit device select code. These inputs must be tied to  $V_{CC}$  or  $V_{SS}$ , to establish the device select code as shown in [Figure 4](#). When not connected (left floating), these inputs are read as low (0,0).

**Figure 4. Device select code**

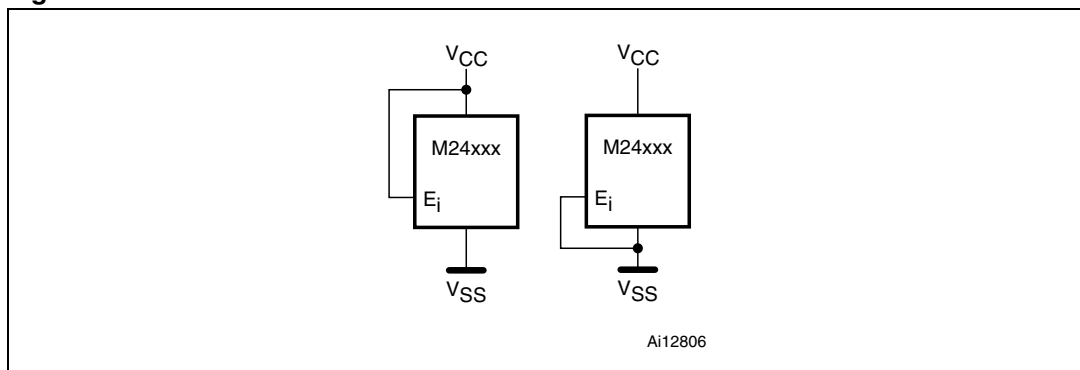

### 2.4 Write Control ( $\overline{WC}$ )

This input signal is useful for protecting the entire contents of the memory from inadvertent write operations. Write operations are disabled to the entire memory array when Write Control ( $\overline{WC}$ ) is driven high. Write operations are enabled when Write Control ( $\overline{WC}$ ) is either driven low or left floating.

When Write Control ( $\overline{WC}$ ) is driven high, device select and address bytes are acknowledged, Data bytes are not acknowledged.

### 2.5 $V_{SS}$ (ground)

$V_{SS}$  is the reference for the  $V_{CC}$  supply voltage.



## 2.6 Supply voltage ( $V_{CC}$ )

### 2.6.1 Operating supply voltage $V_{CC}$

Prior to selecting the memory and issuing instructions to it, a valid and stable  $V_{CC}$  voltage within the specified [ $V_{CC}(\min)$ ,  $V_{CC}(\max)$ ] range must be applied (see Operating conditions in [Section 8: DC and AC parameters](#)). In order to secure a stable DC supply voltage, it is recommended to decouple the  $V_{CC}$  line with a suitable capacitor (usually of the order of 10 nF to 100 nF) close to the  $V_{CC}/V_{SS}$  package pins.

This voltage must remain stable and valid until the end of the transmission of the instruction and, for a write instruction, until the completion of the internal write cycle ( $t_W$ ).

### 2.6.2 Power-up conditions

The  $V_{CC}$  voltage has to rise continuously from 0 V up to the minimum  $V_{CC}$  operating voltage (see Operating conditions in [Section 8: DC and AC parameters](#)) and the rise time must not vary faster than 1 V/ $\mu$ s.

### 2.6.3 Device reset

In order to prevent inadvertent write operations during power-up, a power-on-reset (POR) circuit is included.

At power-up, the device does not respond to any instruction until  $V_{CC}$  has reached the internal reset threshold voltage. This threshold is lower than the minimum  $V_{CC}$  operating voltage (see Operating conditions in [Section 8: DC and AC parameters](#)). When  $V_{CC}$  passes over the POR threshold, the device is reset and enters the Standby Power mode; however, the device must not be accessed until  $V_{CC}$  reaches a valid and stable DC voltage within the specified [ $V_{CC}(\min)$ ,  $V_{CC}(\max)$ ] range (see Operating conditions in [Section 8: DC and AC parameters](#)).

In a similar way, during power-down (continuous decrease in  $V_{CC}$ ), the device must not be accessed when  $V_{CC}$  drops below  $V_{CC}(\min)$ . When  $V_{CC}$  drops below the internal reset threshold voltage, the device stops responding to any instruction sent to it.

### 2.6.4 Power-down conditions

During power-down (continuous decrease in  $V_{CC}$ ), the device must be in the Standby Power mode (mode reached after decoding a Stop condition, assuming that there is no internal write cycle in progress).

### 3 Memory organization

The memory is organized as shown below.

Figure 5. Block diagram

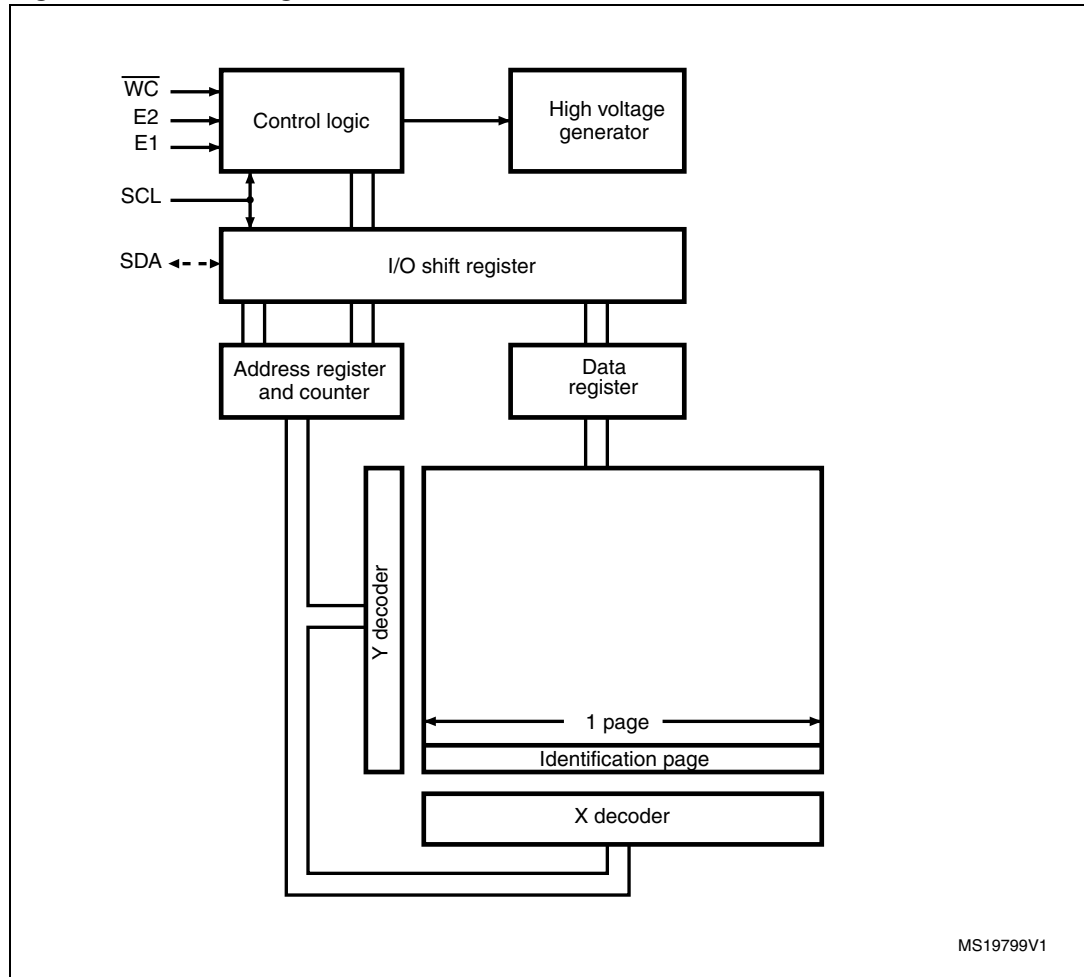

## 4 Device operation

The device supports the I<sup>2</sup>C protocol. This is summarized in *Figure 6*. Any device that sends data on to the bus is defined to be a transmitter, and any device that reads the data to be a receiver. The device that controls the data transfer is known as the bus master, and the other as the slave device. A data transfer can only be initiated by the bus master, which will also provide the serial clock for synchronization. The device is always a slave in all communications.

**Figure 6. I<sup>2</sup>C bus protocol**

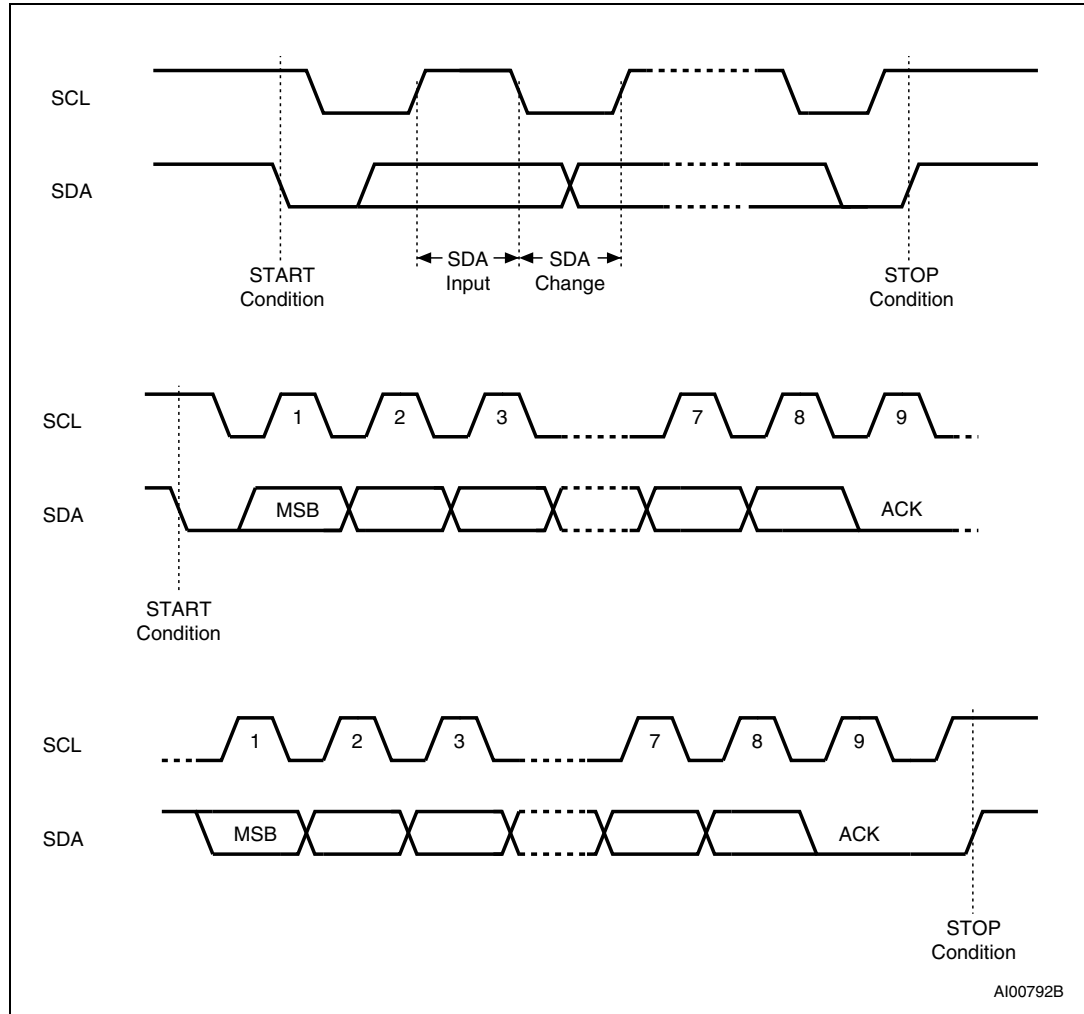

## 4.1 Start condition

Start is identified by a falling edge of Serial Data (SDA) while Serial Clock (SCL) is stable in the high state. A Start condition must precede any data transfer instruction. The device continuously monitors (except during a Write cycle) Serial Data (SDA) and Serial Clock (SCL) for a Start condition.

## 4.2 Stop condition

Stop is identified by a rising edge of Serial Data (SDA) while Serial Clock (SCL) is stable and driven high. A Stop condition terminates communication between the device and the bus master. A Read instruction that is followed by NoAck can be followed by a Stop condition to force the device into the Standby mode.

A Stop condition at the end of a Write instruction triggers the internal Write cycle.

## 4.3 Data input

During data input, the device samples Serial Data (SDA) on the rising edge of Serial Clock (SCL). For correct device operation, Serial Data (SDA) must be stable during the rising edge of Serial Clock (SCL), and the Serial Data (SDA) signal must change *only* when Serial Clock (SCL) is driven low.

## 4.4 Acknowledge bit (ACK)

The acknowledge bit is used to indicate a successful byte transfer. The bus transmitter, whether it be bus master or slave device, releases Serial Data (SDA) after sending eight bits of data. During the 9<sup>th</sup> clock pulse period, the receiver pulls Serial Data (SDA) low to acknowledge the receipt of the eight data bits.

## 4.5 Device addressing

To start communication between the bus master and the slave device, the bus master must initiate a Start condition. Following this, the bus master sends the device select code, shown in [Table 2](#) (on Serial Data (SDA), most significant bit first).

**Table 2. Device select code**

	Device type identifier <sup>(1)</sup>				Chip Enable address <sup>(2)</sup>		Address bit	R $\overline{W}$
	b7	b6	b5	b4	b3	b2	b1	b0
When accessing the memory	1	0	1	0	E2	E1	A16	R $\overline{W}$
When accessing the Identification page	1	0	1	1	E2	E1	X <sup>(3)</sup>	R $\overline{W}$

1. The most significant bit, b7, is sent first.
2. E2,E1 are compared against the external pin on the memory device.
3. X = don't care.

When the device select code is received, the device only responds if the Chip Enable address is the same as the value on its Chip Enable E2,E1 inputs.

The 8<sup>th</sup> bit is the Read/Write bit (R $\overline{W}$ ). This bit is set to 1 for Read and 0 for Write operations.

If a match occurs on the device select code, the corresponding device gives an acknowledgment on Serial Data (SDA) during the 9<sup>th</sup> bit time. If the device does not match the device select code, the device deselects itself from the bus, and goes into Standby mode.

## 5 Instructions

### 5.1 Write operations

Following a Start condition the bus master sends a device select code with the  $R/\overline{W}$  bit ( $R\overline{W}$ ) reset to 0. The device acknowledges this, as shown in [Figure 7](#), and waits for two address bytes. The device responds to each address byte with an acknowledge bit, and then waits for the data byte.

**Table 3. Most significant address byte**

A15	A14	A13	A12	A11	A10	A9	A8
-----	-----	-----	-----	-----	-----	----	----

**Table 4. Least significant address byte**

A7	A6	A5	A4	A3	A2	A1	A0
----	----	----	----	----	----	----	----

*The 128 Kbytes (1 Mb) are addressed with 17 address bits, the 16 lower address bits being defined by the two address bytes and the most significant address bit (A16) being included in the Device Select code (see [Table 2](#)).*

When the bus master generates a Stop condition immediately after a data byte Ack bit (in the “10<sup>th</sup> bit” time slot), either at the end of a Byte Write or a Page Write, the internal Write cycle  $t_W$  is triggered. A Stop condition at any other time slot does not trigger the internal Write cycle.

After the Stop condition and the successful completion of an internal Write cycle ( $t_W$ ), the device internal address counter is automatically incremented to point to the next byte after the last modified byte.

During the internal Write cycle, Serial Data (SDA) is disabled internally, and the device does not respond to any requests.

If the Write Control input (WC) is driven High, the Write instruction is not executed and the accompanying data bytes are *not* acknowledged, as shown in [Figure 8](#).

### 5.1.1 Byte Write

After the device select code and the address bytes, the bus master sends one data byte. If the addressed location is Write-protected, by Write Control ( $\overline{WC}$ ) being driven high, the device replies with NoAck, and the location is not modified. If, instead, the addressed location is not Write-protected, the device replies with Ack. The bus master terminates the transfer by generating a Stop condition, as shown in [Figure 7](#).

**Figure 7. Write mode sequences with  $\overline{WC} = 0$  (data write enabled)**

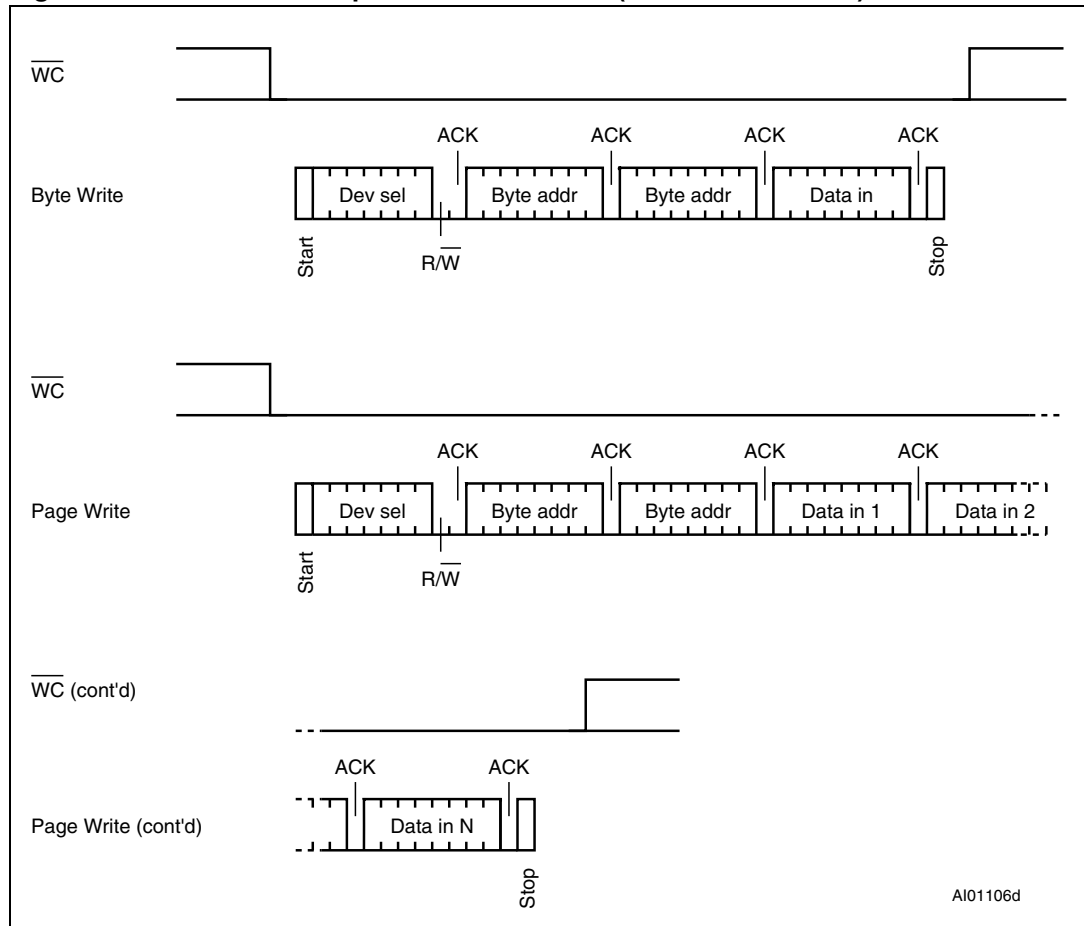

### 5.1.2 Page Write

The Page Write mode allows up to 256 bytes to be written in a single Write cycle, provided that they are all located in the same page in the memory: that is, the most significant memory address bits, b16-b8, are the same. If more bytes are sent than will fit up to the end of the page, a “roll-over” occurs, i.e. the bytes exceeding the page end are written on the same page, from location 0.

The bus master sends from 1 to 256 bytes of data, each of which is acknowledged by the device if Write Control ( $\overline{WC}$ ) is low. If Write Control ( $\overline{WC}$ ) is high, the contents of the addressed memory location are not modified, and each data byte is followed by a NoAck, as shown in *Figure 8*. After each transferred byte, the internal page address counter is incremented.

The transfer is terminated by the bus master generating a Stop condition.

**Figure 8. Write mode sequences with  $\overline{WC} = 1$  (data write inhibited)**

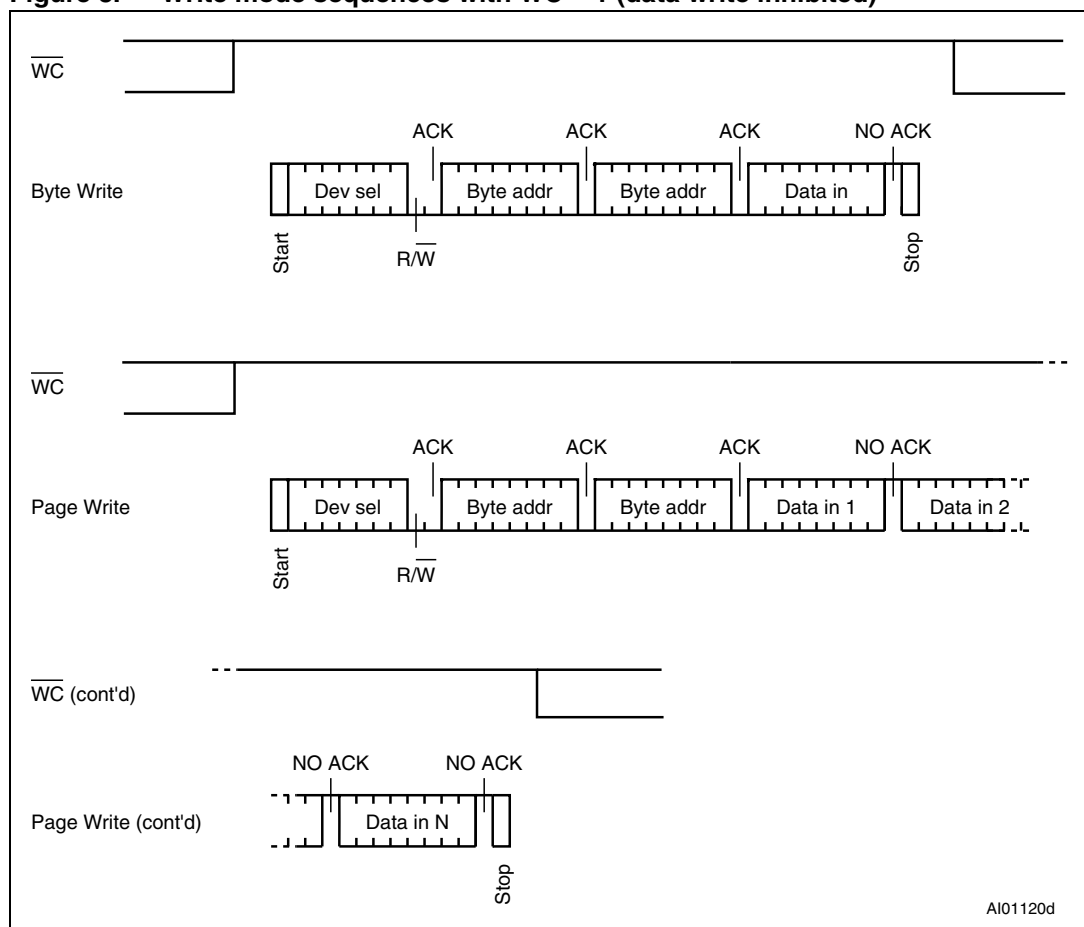



### 5.1.3 Write Identification Page (M24M01-D only)

The Identification Page (256 bytes) is an additional page which can be written and (later) permanently locked in Read-only mode. It is written by issuing the Write Identification Page instruction. This instruction uses the same protocol and format as Page Write (into memory array), except for the following differences:

- Device type identifier = 1011b
- MSB address bits A16/A8 are don't care except for address bit A10 which must be '0'. LSB address bits A7/A0 define the byte address inside the Identification page.

If the Identification page is locked, the data bytes transferred during the Write Identification Page instruction are not acknowledged (NoAck).

### 5.1.4 Lock Identification Page (M24M01-D only)

The Lock Identification Page instruction (Lock ID) permanently locks the Identification page in Read-only mode. The Lock ID instruction is similar to Byte Write (into memory array) with the following specific conditions:

- Device type identifier = 1011b
- Address bit A10 must be '1'; all other address bits are don't care
- The data byte must be equal to the binary value xxxx xx1x, where x is don't care

### 5.1.5 ECC (Error Correction Code) and Write cycling

The Error Correction Code (ECC) is an internal logic function which is transparent for the I<sup>2</sup>C communication protocol.

The ECC logic is implemented on each group of four EEPROM bytes<sup>(a)</sup>. Inside a group, if a single bit out of the four bytes happens to be erroneous during a Read operation, the ECC detects this bit and replaces it with the correct value. The read reliability is therefore much improved.

Even if the ECC function is performed on groups of four bytes, a single byte can be written/cycled independently. In this case, the ECC function also writes/cycles the three other bytes located in the same group<sup>(a)</sup>. As a consequence, the maximum cycling budget is defined at group level and the cycling can be distributed over the 4 bytes of the group: the sum of the cycles seen by byte0, byte1, byte2 and byte3 of the same group must remain below the maximum value defined [Table 10: Cycling performance by groups of four bytes](#).

---

a. A group of four bytes is located at addresses  $[4*N, 4*N+1, 4*N+2, 4*N+3]$ , where N is an integer.

### 5.1.6 Minimizing Write delays by polling on ACK

The maximum Write time ( $t_w$ ) is shown in AC characteristics tables in [Section 8: DC and AC parameters](#), but the typical time is shorter. To make use of this, a polling sequence can be used by the bus master.

The sequence, as shown in [Figure 9](#), is:

- Initial condition: a Write cycle is in progress.
- Step 1: the bus master issues a Start condition followed by a device select code (the first byte of the new instruction).
- Step 2: if the device is busy with the internal Write cycle, no Ack will be returned and the bus master goes back to Step 1. If the device has terminated the internal Write cycle, it responds with an Ack, indicating that the device is ready to receive the second part of the instruction (the first byte of this instruction having been sent during Step 1).

**Figure 9. Write cycle polling flowchart using ACK**

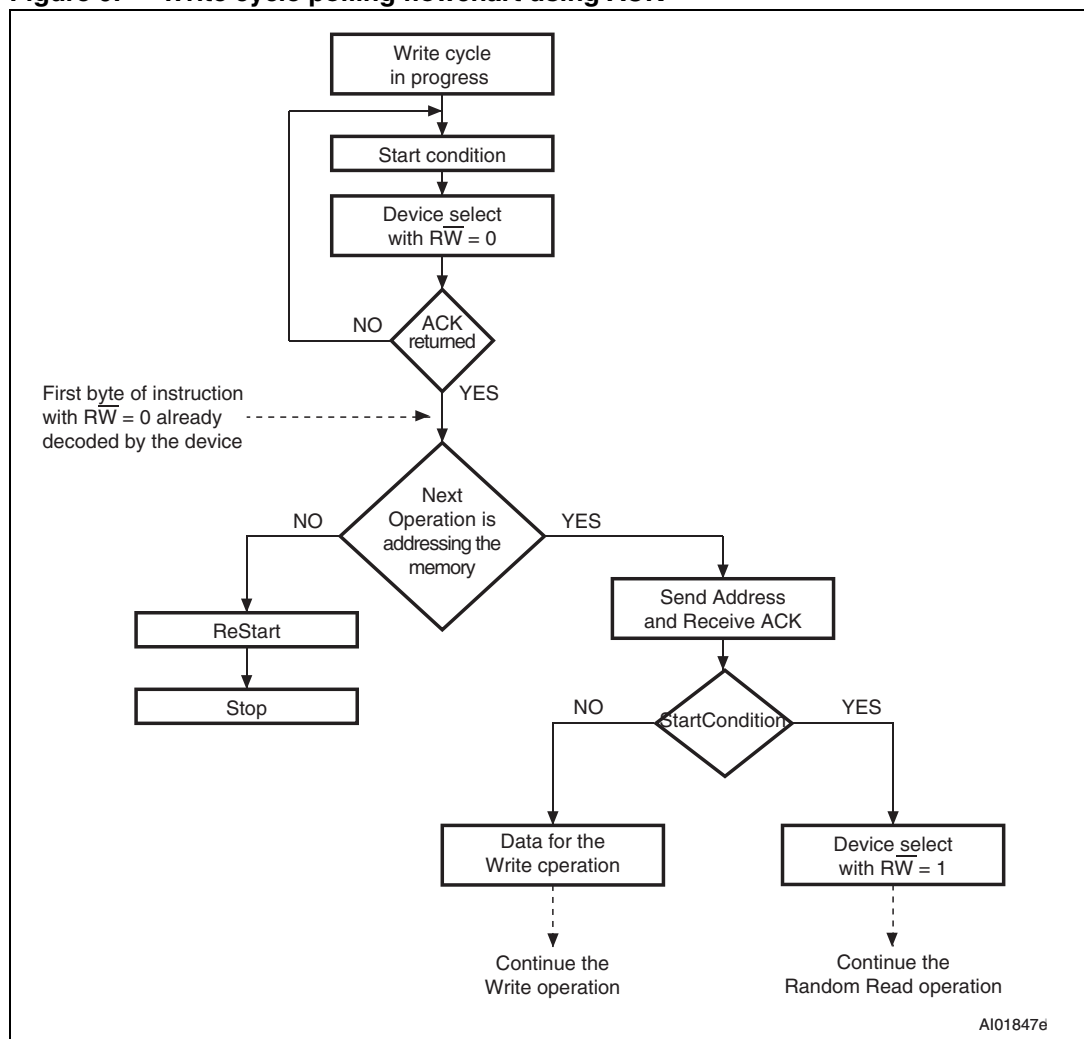

1. The seven most significant bits of the Device Select code of a Random Read (bottom right box in the figure) must be identical to the seven most significant bits of the Device Select code of the Write (polling instruction in the figure).

## 5.2 Read operations

Read operations are performed independently of the state of the Write Control ( $\overline{WC}$ ) signal. After the successful completion of a Read operation, the device internal address counter is incremented by one, to point to the next byte address.

For the Read instructions, after each byte read (data out), the device waits for an acknowledgment (data in) during the 9th bit time. If the bus master does not acknowledge during this 9th time, the device terminates the data transfer and switches to its Standby mode.

**Figure 10. Read mode sequences**

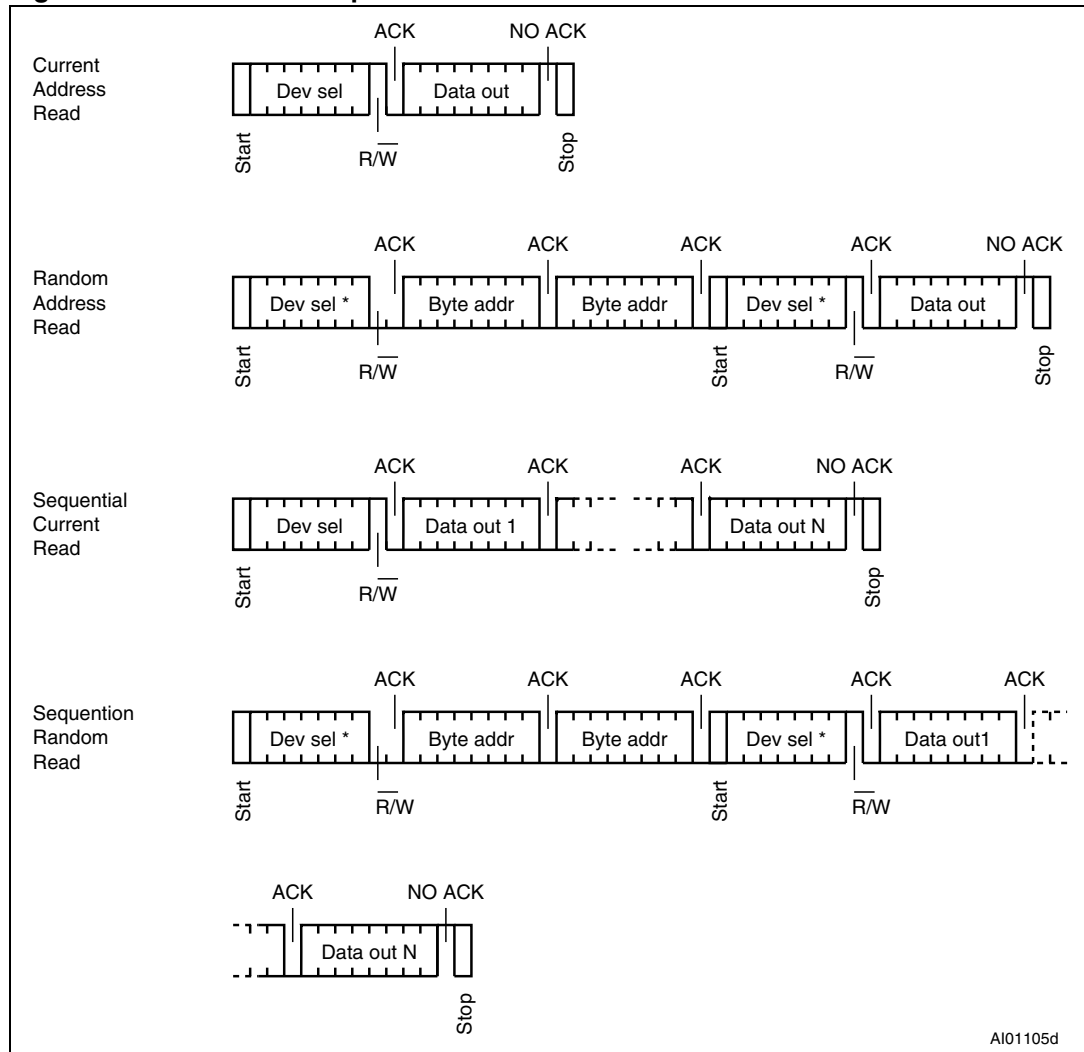

### 5.2.1 Random Address Read

A dummy Write is first performed to load the address into this address counter (as shown in [Figure 10](#)) but *without* sending a Stop condition. Then, the bus master sends another Start condition, and repeats the device select code, with the  $\overline{RW}$  bit set to 1. The device acknowledges this, and outputs the contents of the addressed byte. The bus master must *not* acknowledge the byte, and terminates the transfer with a Stop condition.

### 5.2.2 Current Address Read

For the Current Address Read operation, following a Start condition, the bus master only sends a device select code with the  $\overline{RW}$  bit set to 1. The device acknowledges this, and outputs the byte addressed by the internal address counter. The counter is then incremented. The bus master terminates the transfer with a Stop condition, as shown in [Figure 10](#), *without* acknowledging the byte.

Note that the address counter value is defined by instructions accessing either the memory or the Identification page. When accessing the Identification page, the address counter value is loaded with the byte location in the Identification page, therefore the next Current Address Read in the memory uses this new address counter value. When accessing the memory, it is safer to always use the Random Address Read instruction (this instruction loads the address counter with the byte location to read in the memory, see [Section 5.2.1](#)) instead of the Current Address Read instruction.

### 5.2.3 Sequential Read

This operation can be used after a Current Address Read or a Random Address Read. The bus master *does* acknowledge the data byte output, and sends additional clock pulses so that the device continues to output the next byte in sequence. To terminate the stream of bytes, the bus master must *not* acknowledge the last byte, and *must* generate a Stop condition, as shown in [Figure 10](#).

The output data comes from consecutive addresses, with the internal address counter automatically incremented after each byte output. After the last memory address, the address counter “rolls-over”, and the device continues to output data from memory address 00h.

## 5.3 Read Identification Page (M24M01-D only)

The Identification Page (256 bytes) is an additional page which can be written and (later) permanently locked in Read-only mode.

The Identification Page can be read by issuing an Read Identification Page instruction. This instruction uses the same protocol and format as the Random Address Read (from memory array) with device type identifier defined as 1011b. The MSB address bits A16/A8 are don't care, the LSB address bits A7/A0 define the byte address inside the Identification Page. The number of bytes to read in the ID page must not exceed the page boundary (e.g.: when reading the Identification Page from location 100d, the number of bytes should be less than or equal to 156, as the ID page boundary is 256 bytes).

## 5.4 Read the lock status (M24M01-D only)

The locked/unlocked status of the Identification page can be checked by transmitting a specific truncated command [Identification Page Write instruction + one data byte] to the device. The device returns an acknowledge bit if the Identification page is unlocked, otherwise a NoAck bit if the Identification page is locked.

Right after this, it is recommended to transmit to the device a Start condition followed by a Stop condition, so that:

- Start: the truncated command is not executed because the Start condition resets the device internal logic,
- Stop: the device is then set back into Standby mode by the Stop condition.

## 6 Initial delivery state

The device is delivered with all bits set to 1 (both in the memory array and in the Identification page - that is, each byte contains FFh).

## 7 Maximum rating

Stressing the device outside the ratings listed in [Table 5](#) may cause permanent damage to the device. These are stress ratings only, and operation of the device at these, or any other conditions outside those indicated in the operating sections of this specification, is not implied. Exposure to absolute maximum rating conditions for extended periods may affect device reliability.

**Table 5. Absolute maximum ratings**

Symbol	Parameter	Min.	Max.	Unit
	Ambient operating temperature	-40	130	°C
T <sub>STG</sub>	Storage temperature	-65	150	°C
T <sub>LEAD</sub>	Lead temperature during soldering	see note <sup>(1)</sup>		°C
V <sub>IO</sub>	Input or output range	-0.50	V <sub>CC</sub> +0.6	V
I <sub>OL</sub>	DC output current (SDA = 0)	-	5	mA
V <sub>CC</sub>	Supply voltage	-0.50	6.5	V
V <sub>ESD</sub>	Electrostatic pulse (Human Body model) <sup>(2)</sup>	-	4000 <sup>(3)</sup>	V

1. Compliant with JEDEC Std J-STD-020D (for small body, Sn-Pb or Pb assembly), the ST ECOPACK® 7191395 specification, and the European directive on Restrictions on Hazardous Substances (RoHS) 2002/95/EU.

2. Positive and negative pulses applied on different combinations of pin connections, according to AEC-Q100-002 (compliant with JEDEC Std JESD22-A114, C1=100 pF, R1=1500 Ω).

3. 3000 V for previous devices (process letter A or B).

## 8 DC and AC parameters

This section summarizes the operating and measurement conditions, and the DC and AC characteristics of the device.

**Table 6. Operating conditions (voltage range R)**

Symbol	Parameter	Min.	Max.	Unit
$V_{CC}$	Supply voltage	1.8	5.5	V
$T_A$	Ambient operating temperature	-40	85	°C
$f_C$	Operating clock frequency	-	1	MHz

**Table 7. Operating conditions (voltage range F)**

Symbol	Parameter	Min.	Max.	Unit
$V_{CC}$	Supply voltage	1.7	5.5	V
$T_A$	Ambient operating temperature	-40	85	°C
$f_C$	Operating clock frequency	-	1	MHz

**Table 8. AC measurement conditions**

Symbol	Parameter	Min.	Max.	Unit
$C_{bus}$	Load capacitance	100		pF
	SCL input rise/fall time, SDA input fall time	-	50	ns
	Input levels	0.2 $V_{CC}$ to 0.8 $V_{CC}$		V
	Input and output timing reference levels	0.3 $V_{CC}$ to 0.7 $V_{CC}$		V

**Figure 11. AC measurement I/O waveform**

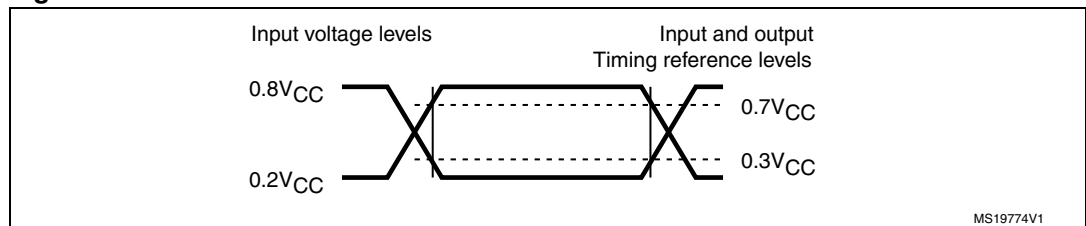

**Table 9. Input parameters**

Symbol	Parameter <sup>(1)</sup>	Test condition	Min.	Max.	Unit
$C_{IN}$	Input capacitance (SDA)			8	pF
$C_{IN}$	Input capacitance (other pins)			6	pF
$Z_L$	Input impedance ( $\overline{WC}$ )	$V_{IN} < 0.3 V_{CC}$	30		kΩ
$Z_H$		$V_{IN} > 0.7 V_{CC}$	400		kΩ

1. Sampled only, not 100% tested.



**Table 10. Cycling performance by groups of four bytes**

Symbol	Parameter	Test condition <sup>(1)</sup>	Max.	Unit
Ncycle	Write cycle endurance <sup>(2)</sup>	$TA \leq 25\text{ }^{\circ}\text{C}, V_{CC}(\text{min}) < V_{CC} < V_{CC}(\text{max})$	4,000,000	Write cycle <sup>(3)</sup>
		$TA = 85\text{ }^{\circ}\text{C}, V_{CC}(\text{min}) < V_{CC} < V_{CC}(\text{max})$	1,200,000	

1. Cycling performance for products identified by process letter K.
2. The Write cycle endurance is defined for groups of four data bytes located at addresses  $[4*N, 4*N+1, 4*N+2, 4*N+3]$  where N is an integer. The Write cycle endurance is defined by characterization and qualification.
3. A Write cycle is executed when either a Page Write, a Byte Write, a Write Identification Page or a Lock Identification Page instruction is decoded. When using the Byte Write, the Page Write or the Write Identification Page, refer also to [Section 5.1.5: ECC \(Error Correction Code\) and Write cycling](#).

**Table 11. Memory cell data retention**

Parameter	Test condition	Min.	Unit
Data retention <sup>(1)</sup>	$TA = 55\text{ }^{\circ}\text{C}$	200	Year

1. For products identified by process letter K. The data retention behavior is checked in production. The 200-year limit is defined from characterization and qualification results.

**Table 12. DC characteristics (M24M01-R, device grade 6)**

Symbol	Parameter	Test conditions (in addition to those in <a href="#">Table 6</a> )	Min.	Max.	Unit
$I_{LI}$	Input leakage current (E1, E2, SCL, SDA)	$V_{IN} = V_{SS}$ or $V_{CC}$ device in Standby mode		$\pm 2$	$\mu A$
$I_{LO}$	Output leakage current	SDA in Hi-Z, external voltage applied on SDA: $V_{SS}$ or $V_{CC}$		$\pm 2$	$\mu A$
$I_{CC}$	Supply current (Read)	$V_{CC} = 1.8 V, f_c = 400 kHz$		1 <sup>(1)</sup>	mA
		$V_{CC} = 2.5 V, f_c = 400 kHz$		1	mA
		$V_{CC} = 5.5 V, f_c = 400 kHz$		1.5 <sup>(2)</sup>	mA
		$f_c = 1 MHz$		1.5 <sup>(3)</sup>	mA
$I_{CC0}$	Supply current (Write)	During $t_w$		2 <sup>(4)(5)</sup>	mA
$I_{CC1}$	Standby supply current	Device not selected, $V_{IN} = V_{SS}$ or $V_{CC}, V_{CC} = 1.8 V$		3 <sup>(6)</sup>	$\mu A$
		Device not selected, $V_{IN} = V_{SS}$ or $V_{CC}, V_{CC} = 2.5 V$		3 <sup>(7)</sup>	$\mu A$
		Device not selected, $V_{IN} = V_{SS}$ or $V_{CC}, V_{CC} = 5.5 V$		5 <sup>(8)</sup>	$\mu A$
$V_{IL}$	Input low voltage (SCL, SDA, WC)	$1.8 V \leq V_{CC} < 2.5 V$	-0.45	$0.25 V_{CC}$	V
		$2.5 V \leq V_{CC} < 5.5 V$	-0.45	$0.30 V_{CC}$	V
$V_{IH}$	Input high voltage (SCL, SDA)	$1.8 V \leq V_{CC} < 2.5 V$	$0.75 V_{CC}$	$V_{CC}+1$	v
		$2.5 V \leq V_{CC} < 5.5 V$	$0.70 V_{CC}$	$0 V_{CC}+1$	v
$V_{OL}$	Output low voltage	$I_{OL} = 1.0 mA, V_{CC} = 1.8 V$		0.2	V
		$I_{OL} = 2.1 mA, V_{CC} = 2.5 V$		0.4	V
		$I_{OL} = 3.0 mA, V_{CC} = 5.5 V$		0.4	V

1. Devices identified by process letter A or B offer  $I_{CC} = 0.8 mA$
2. The previous product identified by process letter A or B was specified with  $I_{cc(max)} = 2 mA$ .
3. Devices identified by process letter A or B offer  $I_{CC} = 2.5 mA$ .
4. Characterized only, not tested in production.
5. The previous product identified by process letter A or B was characterized with  $I_{cc0(max)} = 5 mA$ .
6. Devices identified by process letter A or B offer  $I_{CC1} = 1 \mu A$ .
7. Devices identified by process letter A or B offer  $I_{CC1} = 2 \mu A$ .
8. Devices identified by process letter A or B offer  $I_{CC1} = 3 \mu A$ .

Table 13. DC characteristics (M24M01-F, device grade 6)

Symbol	Parameter	Test conditions (in addition to those in Table 6)	Min.	Max.	Unit
$I_{LI}$	Input leakage current (E1, E2, SCL, SDA)	$V_{IN} = V_{SS}$ or $V_{CC}$ device in Standby mode		$\pm 2$	$\mu A$
$I_{LO}$	Output leakage current	SDA in Hi-Z, external voltage applied on SDA: $V_{SS}$ or $V_{CC}$		$\pm 2$	$\mu A$
$I_{CC}$	Supply current (Read)	$V_{CC} = 1.7 V, f_c = 400 kHz$		1	mA
		$V_{CC} = 2.5 V, f_c = 400 kHz$		1	mA
		$V_{CC} = 5.5 V, f_c = 400 kHz$		1.5	mA
		$f_c = 1 MHz$		1.5	mA
$I_{CC0}$	Supply current (Write)	During $t_W$		2 <sup>(1)</sup>	mA
$I_{CC1}$	Standby supply current	Device not selected, $V_{IN} = V_{SS}$ or $V_{CC}, V_{CC} = 1.7 V$		3	$\mu A$
		Device not selected, $V_{IN} = V_{SS}$ or $V_{CC}, V_{CC} = 2.5 V$		3	$\mu A$
		Device not selected, $V_{IN} = V_{SS}$ or $V_{CC}, V_{CC} = 5.5 V$		5	$\mu A$
$V_{IL}$	Input low voltage (SCL, SDA, WC)	$1.7 V \leq V_{CC} < 2.5 V$	-0.45	$0.25 V_{CC}$	V
		$2.5 V \leq V_{CC} < 5.5 V$	-0.45	$0.30 V_{CC}$	V
$V_{IH}$	Input high voltage (SCL, SDA)	$1.7 V \leq V_{CC} < 2.5 V$	$0.75 V_{CC}$	$V_{CC}+1$	v
		$2.5 V \leq V_{CC} < 5.5 V$	$0.70 V_{CC}$	$0 V_{CC}+1$	v
$V_{OL}$	Output low voltage	$I_{OL} = 1.0 mA, V_{CC} = 1.7 V$		0.2	V
		$I_{OL} = 2.1 mA, V_{CC} = 2.5 V$		0.4	V
		$I_{OL} = 3.0 mA, V_{CC} = 5.5 V$		0.4	V

1. Characterized only, not tested in production.

Table 14. 400 kHz AC characteristics

Symbol	Alt.	Parameter	Min.	Max.	Unit
$f_C$	$f_{SCL}$	Clock frequency	-	400	kHz
$t_{CHCL}$	$t_{HIGH}$	Clock pulse width high	600	-	ns
$t_{CLCH}$	$t_{LOW}$	Clock pulse width low	1300	-	ns
$t_{QL1QL2}^{(1)}$	$t_F$	SDA (out) fall time	20 <sup>(2)</sup>	300	ns
$t_{XH1XH2}$	$t_R$	Input signal rise time	(3)	(3)	ns
$t_{XL1XL2}$	$t_F$	Input signal fall time	(3)	(3)	ns
$t_{DXCH}$	$t_{SU:DAT}$	Data in set up time	100	-	ns
$t_{CLDX}$	$t_{HD:DAT}$	Data in hold time	0	-	ns
$t_{CLQX}^{(4)}$	$t_{DH}$	Data out hold time	100 <sup>(5)</sup>	-	ns
$t_{CLQV}^{(6)}$	$t_{AA}$	Clock low to next data valid (access time)	-	900	ns
$t_{CHDL}$	$t_{SU:STA}$	Start condition setup time	600	-	ns
$t_{DLCL}$	$t_{HD:STA}$	Start condition hold time	600	-	ns
$t_{CHDH}$	$t_{SU:STO}$	Stop condition set up time	600	-	ns
$t_{DHDL}$	$t_{BUF}$	Time between Stop condition and next Start condition	1300	-	ns
$t_{WLDL}^{(7)(1)}$	$t_{SU:WC}$	$\overline{WC}$ set up time (before the Start condition)	0	-	$\mu$ s
$t_{DHWL}^{(8)(1)}$	$t_{HD:WC}$	$\overline{WC}$ hold time (after the Stop condition)	1	-	$\mu$ s
$t_W$	$t_{WR}$	Internal Write cycle duration	-	5	ms
$t_{NS}^{(1)}$		Pulse width ignored (input filter on SCL and SDA) - single glitch	-	80 <sup>(9)</sup>	ns

1. Characterized only, not tested in production.
2. With  $C_L = 10$  pF.
3. There is no min. or max. values for the input signal rise and fall times. It is however recommended by the I<sup>2</sup>C specification that the input signal rise and fall times be more than 20 ns and less than 300 ns when  $f_C < 400$  kHz.
4. To avoid spurious Start and Stop conditions, a minimum delay is placed between SCL=1 and the falling or rising edge of SDA.
5. The previous product identified by process letter P was specified with  $t_{CLQX} = 200$  ns (min). Both values offer a safe margin compared to the I<sup>2</sup>C specification recommendations.
6.  $t_{CLOV}$  is the time (from the falling edge of SCL) required by the SDA bus line to reach either  $0.3V_{CC}$  or  $0.7V_{CC}$ , assuming that  $R_{bus} \times C_{bus}$  time constant is within the values specified in [Figure 12](#).
7.  $\overline{WC}=0$  set up time condition to enable the execution of a WRITE command.
8.  $\overline{WC}=0$  hold time condition to enable the execution of a WRITE command.
9. The previous product identified by process letter A or B was specified with  $t_{NS} = 100$  ns (max).

Table 15. 1 MHz AC characteristics

Symbol	Alt.	Parameter	Min.	Max.	Unit
$f_C$	$f_{SCL}$	Clock frequency	0	1	MHz
$t_{CHCL}$	$t_{HIGH}$	Clock pulse width high	300	-	ns
$t_{CLCH}$	$t_{LOW}$	Clock pulse width low	400	-	ns
$t_{XH1XH2}$	$t_R$	Input signal rise time	(1)	(1)	ns
$t_{XL1XL2}$	$t_F$	Input signal fall time	(1)	(1)	ns
$t_{QL1QL2}^{(8)}$	$t_F$	SDA (out) fall time	-	120	ns
$t_{DXCX}$	$t_{SU:DAT}$	Data in setup time	80	-	ns
$t_{CLDX}$	$t_{HD:DAT}$	Data in hold time	0	-	ns
$t_{CLQX}^{(2)}$	$t_{DH}$	Data out hold time	50	-	ns
$t_{CLQV}^{(3)}$	$t_{AA}$	Clock low to next data valid (access time)	-	500	ns
$t_{CHDL}$	$t_{SU:STA}$	Start condition setup time	250	-	ns
$t_{DLCL}$	$t_{HD:STA}$	Start condition hold time	250	-	ns
$t_{CHDH}$	$t_{SU:STO}$	Stop condition setup time	250	-	ns
$t_{DHDL}$	$t_{BUF}$	Time between Stop condition and next Start condition	500	-	ns
$t_{WLDL}^{(4)(8)}$	$t_{SU:WC}$	$\overline{WC}$ set up time (before the Start condition)	0	-	$\mu$ s
$t_{DHWL}^{(5)(8)}$	$t_{HD:WC}$	$\overline{WC}$ hold time (after the Stop condition)	1	-	$\mu$ s
$t_W$	$t_{WR}$	Write time	-	5	ms
$t_{NS}^{(6)}$		Pulse width ignored (input filter on SCL and SDA)	-	80 <sup>(7)</sup>	ns

1. There is no min. or max. values for the input signal rise and fall times. It is however recommended by the I<sup>2</sup>C specification that the input signal rise and fall times be more than 20 ns and less than 120 ns when  $f_C < 1$  MHz.
2. To avoid spurious Start and Stop conditions, a minimum delay is placed between SCL=1 and the falling or rising edge of SDA.
3.  $t_{CLQV}$  is the time (from the falling edge of SCL) required by the SDA bus line to reach either 0.3  $V_{CC}$  or 0.7  $V_{CC}$ , assuming that the  $R_{bus} \times C_{bus}$  time constant is within the values specified in [Figure 13](#).
4.  $\overline{WC}=0$  set up time condition to enable the execution of a WRITE command.
5.  $\overline{WC}=0$  hold time condition to enable the execution of a WRITE command.
6. Characterized only, not tested in production.
7. The previous product identified by process letter A or B was specified with  $t_{NS} = 50$  ns (max).

**Figure 12. Maximum  $R_{bus}$  value versus bus parasitic capacitance ( $C_{bus}$ ) for an I<sup>2</sup>C bus at maximum frequency  $f_C = 400$  kHz**

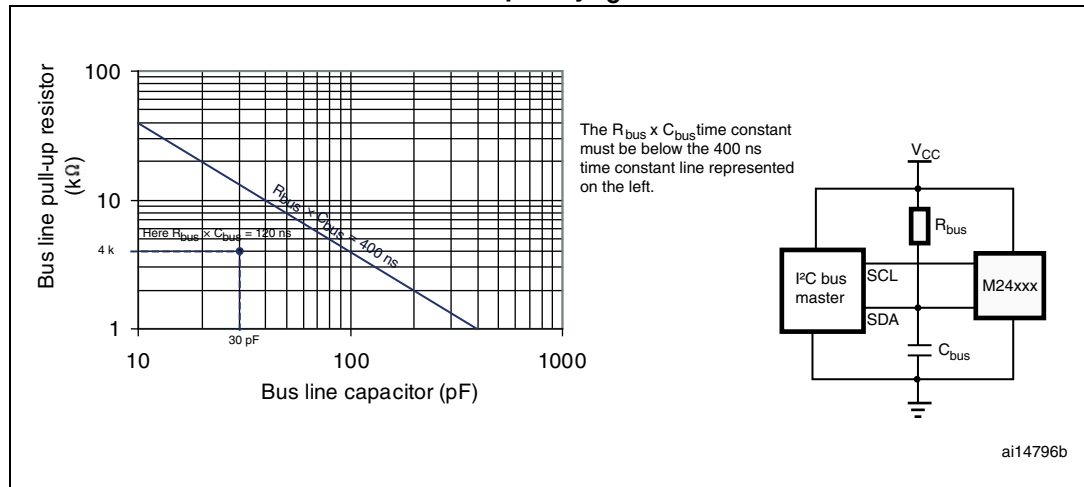

**Figure 13. Maximum  $R_{bus}$  value versus bus parasitic capacitance  $C_{bus}$ ) for an I<sup>2</sup>C bus at maximum frequency  $f_C = 1$  MHz**

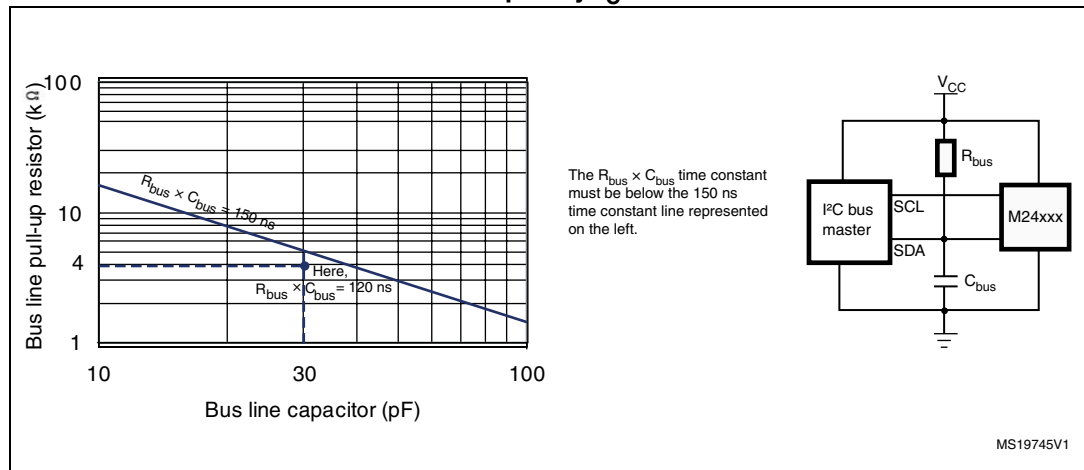
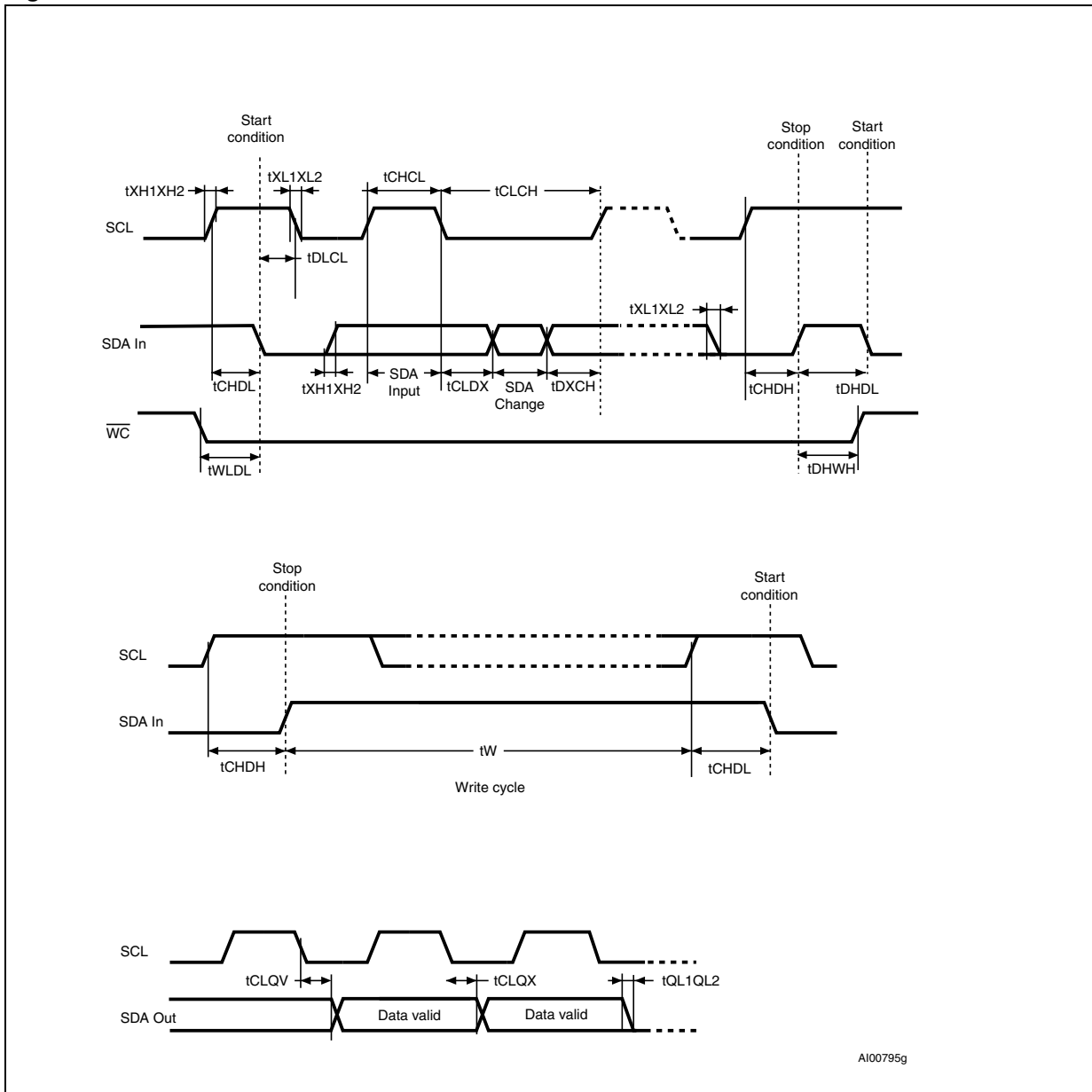

Figure 14. AC waveforms



## 9 Package mechanical data

In order to meet environmental requirements, ST offers these devices in different grades of ECOPACK® packages, depending on their level of environmental compliance. ECOPACK® specifications, grade definitions and product status are available at: [www.st.com](http://www.st.com). ECOPACK® is an ST trademark.

**Figure 15. TSSOP8 – 8-lead thin shrink small outline, package outline**

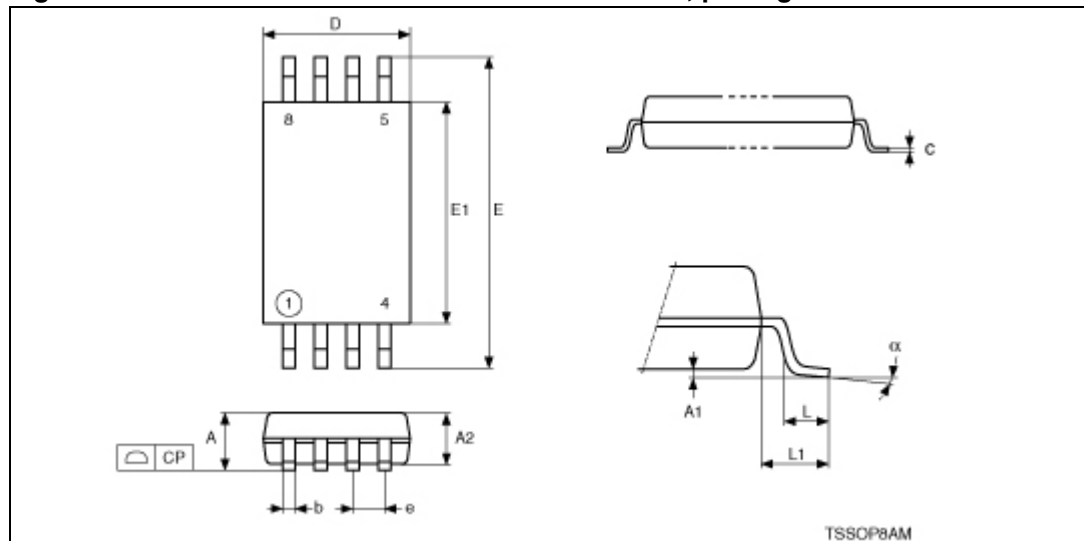

1. Drawing is not to scale.

**Table 16. TSSOP8 – 8-lead thin shrink small outline, package mechanical data**

Symbol	millimeters			inches <sup>(1)</sup>		
	Typ.	Min.	Max.	Typ.	Min.	Max.
A			1.200			0.0472
A1		0.050	0.150		0.0020	0.0059
A2	1.000	0.800	1.050	0.0394	0.0315	0.0413
b		0.190	0.300		0.0075	0.0118
c		0.090	0.200		0.0035	0.0079
CP			0.100			0.0039
D	3.000	2.900	3.100	0.1181	0.1142	0.1220
e	0.650			0.0256		
E	6.400	6.200	6.600	0.2520	0.2441	0.2598
E1	4.400	4.300	4.500	0.1732	0.1693	0.1772
L	0.600	0.450	0.750	0.0236	0.0177	0.0295
L1	1.000			0.0394		
α		0°	8°		0°	8°

1. Values in inches are converted from mm and rounded to four decimal digits.



Figure 16. SO8N – 8 lead plastic small outline, 150 mils body width, package outline

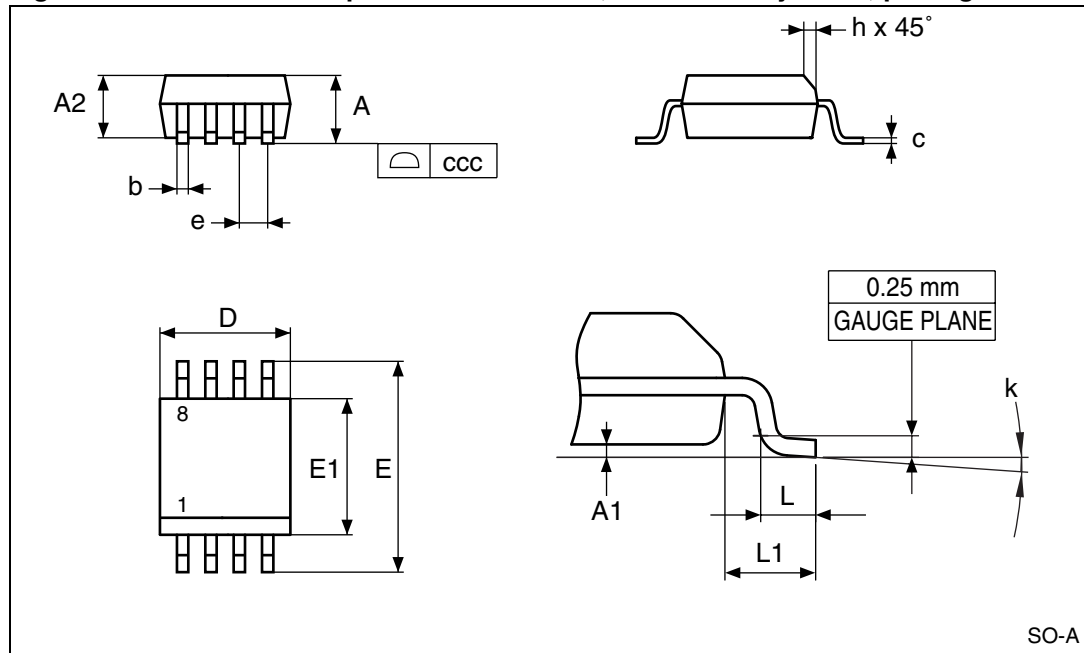

1. Drawing is not to scale.

Table 17. SO8N – 8 lead plastic small outline, 150 mils body width, package data

Symbol	millimeters			inches <sup>(1)</sup>		
	Typ	Min	Max	Typ	Min	Max
A			1.750			0.0689
A1		0.100	0.250		0.0039	0.0098
A2		1.250			0.0492	
b		0.280	0.480		0.0110	0.0189
c		0.170	0.230		0.0067	0.0091
ccc			0.100			0.0039
D	4.900	4.800	5.000	0.1929	0.1890	0.1969
E	6.000	5.800	6.200	0.2362	0.2283	0.2441
E1	3.900	3.800	4.000	0.1535	0.1496	0.1575
e	1.270			0.0500		
h		0.250	0.500		0.0098	0.0197
k		0°	8°		0°	8°
L		0.400	1.270		0.0157	0.0500
L1	1.040			0.0409		

1. Values in inches are converted from mm and rounded to four decimal digits.

Figure 17. M24M01 DFCS6TP/K, WLCSP 8-bump wafer-level chip scale package outline

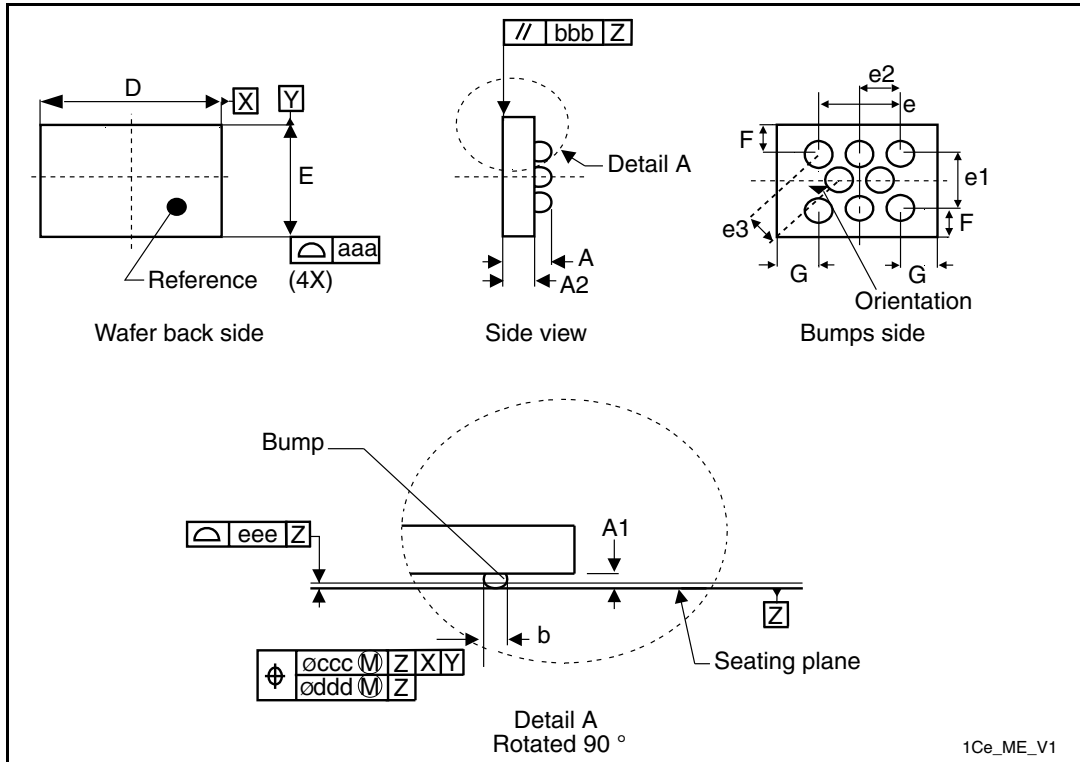

1. Drawing is not to scale.

**Table 18. M24M01-DFCS6TP/K, WLCSP 8-bump wafer-level chip scale package mechanical data**

Symbol	millimeters			inches <sup>(1)</sup>		
	Typ	Min	Max	Typ	Min	Max
A	0.540	0.500	0.580	0.0213	0.0197	0.0228
A1	0.190			0.0075		
A2	0.350			0.0138		
b	0.270			0.0106		
D	2.560		2.580	0.1008		0.1016
E	1.698		1.718	0.0669		0.0676
e	1.000			0.0394		
e1	0.866			0.0341		
e2	0.500			0.0197		
e3	0.500			0.0197		
F	0.416			0.0164		
G	0.780			0.0307		
N (number of terminals)	8			8		
aaa	0.110			0.0039		
bbb	0.110			0.0039		
ccc	0.110			0.0039		
ddd	0.060			0.0020		
eee	0.060			0.0020		

1. Values in inches are converted from mm and rounded to four decimal digits.

# 10 Part numbering

**Table 19. Ordering information scheme**

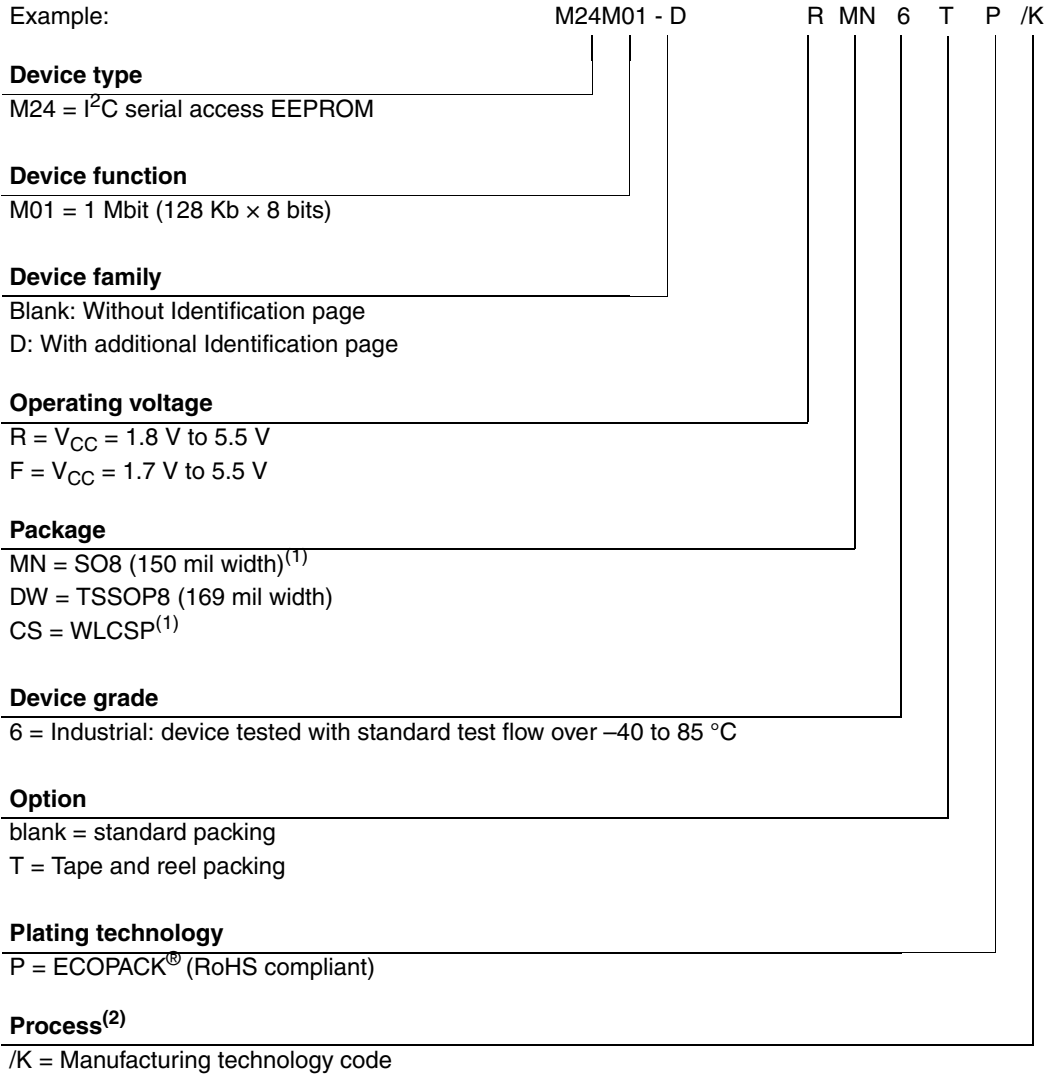

1. RoHS-compliant and halogen-free (ECOPACK2<sup>®</sup>)
2. The process letters apply to WLCSP devices only. The process letters appear on the device package (marking) and on the shipment box. Please contact your nearest ST Sales Office for further information.

# 11 Revision history

**Table 20. Document revision history**

Date	Revision	Changes
02-May-2011	8	<p>Updated <i>Features on page 1</i>.</p> <p>Updated <i>Figure 3: WLCSP8 connections (bumps side view)</i>, <i>Figure 5: Maximum Rbus value versus bus parasitic capacitance (Cbus) for an I2C bus at maximum frequency fC = 400 kHz</i> and <i>Figure 6: Maximum Rbus value versus bus parasitic capacitance (Cbus) for an I2C bus at maximum frequency fC = 1MHz</i>.</p> <p>Updated <i>Table 10: DC characteristics (M24M01-R and M24M01-HR)</i>.</p> <p>Updated footnote 5 of <i>Table 14: AC characteristics at 1 MHz (M24M01-HR)</i>.</p> <p>Modified description of Write Control in <i>Section 3.6: Write operations</i>.</p> <p>Replaced <math>C_L</math> with <math>C_{bus}</math> in <i>Table 7: AC measurement conditions</i>.</p> <p>Changed note 4 about <math>t_{CLQV}</math> in <i>Table 13: AC characteristics at 400 kHz (M24M01-R and M24M01-W)</i>.</p>
23-Apr-2012	9	<p>Datasheet split into:</p> <ul style="list-style-type: none"> <li>– M24M01-R, M24M01-DF (this datasheet) for standard products (range 6),</li> <li>– M24M01-125 datasheet for automotive products (range 3).</li> </ul>
26-Sep-2012	10	<p>Updated:</p> <ul style="list-style-type: none"> <li>– <i>Section 5.2.2: Current Address Read</i></li> <li>– <i>Table 2: Device select code</i></li> <li>– WLCSP package</li> </ul> <p>Changed layout of <i>Features</i>.</p> <p>Rephrased some parts of <i>Section 5.1.2: Page Write</i>, <i>Section 5.2: Read operations</i>, <i>Table 10: Cycling performance by groups of four bytes</i> and <i>Table 11: Memory cell data retention</i>.</p>

**Please Read Carefully:**

Information in this document is provided solely in connection with ST products. STMicroelectronics NV and its subsidiaries ("ST") reserve the right to make changes, corrections, modifications or improvements, to this document, and the products and services described herein at any time, without notice.

All ST products are sold pursuant to ST's terms and conditions of sale.

Purchasers are solely responsible for the choice, selection and use of the ST products and services described herein, and ST assumes no liability whatsoever relating to the choice, selection or use of the ST products and services described herein.

No license, express or implied, by estoppel or otherwise, to any intellectual property rights is granted under this document. If any part of this document refers to any third party products or services it shall not be deemed a license grant by ST for the use of such third party products or services, or any intellectual property contained therein or considered as a warranty covering the use in any manner whatsoever of such third party products or services or any intellectual property contained therein.

**UNLESS OTHERWISE SET FORTH IN ST'S TERMS AND CONDITIONS OF SALE ST DISCLAIMS ANY EXPRESS OR IMPLIED WARRANTY WITH RESPECT TO THE USE AND/OR SALE OF ST PRODUCTS INCLUDING WITHOUT LIMITATION IMPLIED WARRANTIES OF MERCHANTABILITY, FITNESS FOR A PARTICULAR PURPOSE (AND THEIR EQUIVALENTS UNDER THE LAWS OF ANY JURISDICTION), OR INFRINGEMENT OF ANY PATENT, COPYRIGHT OR OTHER INTELLECTUAL PROPERTY RIGHT.**

**UNLESS EXPRESSLY APPROVED IN WRITING BY TWO AUTHORIZED ST REPRESENTATIVES, ST PRODUCTS ARE NOT RECOMMENDED, AUTHORIZED OR WARRANTED FOR USE IN MILITARY, AIR CRAFT, SPACE, LIFE SAVING, OR LIFE SUSTAINING APPLICATIONS, NOR IN PRODUCTS OR SYSTEMS WHERE FAILURE OR MALFUNCTION MAY RESULT IN PERSONAL INJURY, DEATH, OR SEVERE PROPERTY OR ENVIRONMENTAL DAMAGE. ST PRODUCTS WHICH ARE NOT SPECIFIED AS "AUTOMOTIVE GRADE" MAY ONLY BE USED IN AUTOMOTIVE APPLICATIONS AT USER'S OWN RISK.**

Resale of ST products with provisions different from the statements and/or technical features set forth in this document shall immediately void any warranty granted by ST for the ST product or service described herein and shall not create or extend in any manner whatsoever, any liability of ST.

ST and the ST logo are trademarks or registered trademarks of ST in various countries.

Information in this document supersedes and replaces all information previously supplied.

The ST logo is a registered trademark of STMicroelectronics. All other names are the property of their respective owners.

© 2012 STMicroelectronics - All rights reserved

STMicroelectronics group of companies

Australia - Belgium - Brazil - Canada - China - Czech Republic - Finland - France - Germany - Hong Kong - India - Israel - Italy - Japan - Malaysia - Malta - Morocco - Philippines - Singapore - Spain - Sweden - Switzerland - United Kingdom - United States of America

[www.st.com](http://www.st.com)